

Crema Francesco
di
Crema Morgan e Marika & C. s.n.c.
Via Correr, 148
35040 Casale di Scodosia (Pd) Italy
Telefono: +39 **0429 878886**
e-mail: info@mobilicremafrancesco.com - fracrema@tin.it
web: www.mobilicremafrancesco.com



LE MODE' ^{by} *Crema Francesco*

ZEFIRO



ZEFIRO

italian *furnishings* design
by
Crema Francesco



L'estetica, il design, le forme e la funzionalità dell'ambiente: tutti elementi basati sul principio della ricerca e dell'innovazione. Ultimamente si sente molto parlare di arredamento in stile contemporaneo. Molti pensano erroneamente che dire contemporaneo e dire moderno sia la stessa cosa, che i due stili siano coincidenti. In realtà, lo stile contemporaneo è uno stile unico e particolare, che non va confuso con quello moderno. Lo stile contemporaneo è infatti uno stile che ricerca un'unione tra presente e passato, tra tradizione e innovazione. Esso è uno stile che cerca di venire incontro alle innovazioni tecnologiche, ai cambiamenti delle abitudini di vita, dei tempi e del modo di vivere in famiglia, tentando però di mantenere nella casa il calore e l'armonia tipiche delle abitazioni del passato. Proprio per questo motivo, ciò che caratterizza di più l'arredamento contemporaneo sono i colori chiari e luminosi, con una dominante presenza del bianco o del black and white, le linee geometriche e pulite e l'utilizzo di materiali o pregiati, come ad esempio il legno massello, o moderni e innovativi, come il frassino. Infine, tipica di questo tipo di arredamento è la particolare attenzione a introdurre in modo armonico e coerente all'interno dell'ambiente le tecnologie di ultima generazione. Le parole d'ordine sono semplicità, comodità d'uso e attenzione all'estetica. L'obiettivo è realizzare ambienti ordinati e all'avanguardia, comodi e di design.

The aesthetics, design, shapes and functionality of the environment: all elements based on the principle of research and innovation. Lately we hear a lot about contemporary-style furniture. Many mistakenly think that saying contemporary and saying modern is the same thing, that the two styles are coincident. In reality, contemporary style is a unique and particular style, which should not be confused with the modern one. Contemporary style is in fact a style that seeks a union between present and past, between tradition and innovation. It is a style that seeks to meet technological innovations, changes in lifestyle, times and the way of life in the family, while trying to maintain the warmth and harmony typical of homes of the past in the home. Precisely for this reason, what characterizes contemporary furniture most are light and bright colors, with a dominant presence of white or black and white, geometric and clean lines and the use of materials or fine materials, such as solid wood, or modern and innovative, such as ash. Finally, typical of this type of furniture is the particular attention to harmoniously and coherently introduce the latest generation technologies inside the environment. The keywords are simplicity, ease of use and attention to aesthetics. The goal is to create orderly and avantgarde, comfortable and design environments.

arredamento
contemporaneo
e classico
per la casa

contemporary
furniture design



Anthologia 2.4

La collezione madie contemporanee unisce lo stile antico della tradizione del mobile al moderno gusto estetico e marcato di un mobile di lusso. La qualità del made in Italy è da sempre caratteristica di rinomata qualità sia nei materiali, sia nelle rifiniture, che nella composizione del mobile. L'interessante dualità che nasconde ogni mobile permette di adattarsi a più arredamenti dando valore e differenza allo stesso tempo. Lo spazio living delle abitazioni, ma anche delle zone lavoro, deve lasciar trasparire il gusto di chi ci abita e deve esprimere carattere, poiché rappresenta l'ambiente in cui si passa la maggior parte del tempo, e dove si accolgono gli ospiti. Se ami lo stile raffinato e contemporaneo, ma che sa guardare con stile e passione al classico, ti offriamo un'ampia scelta di madie e credenze capaci di sposare al meglio il design alla ricerca dei materiali, trasformando in realtà quelli che sono i tuoi gusti di stile. Le madie presenti in catalogo sono l'emblema del connubio tra modernità e funzionalità che sfocia nell'Italian Design, un principio di arredo che vede la fusione omogenea tra ideale e concretezza, un rapporto di pesi in grado di avvolgere gli ambienti creando un carattere distinto e riconoscibile. L'armonia di costruzione e l'alta qualità dei materiali bene si sposano con i colori senza tempo del legno di qualità, capaci di infondere calore e trasmettere piacevoli sensazioni di comfort e serenità. Le affascinanti sfumature delle madie moderne bene si uniscono con i mobili soggiorno componibili.

The cupboard collection combines the ancient style of the furniture tradition with the modern aesthetic taste marked of a luxury piece of furniture. The quality of Made in Italy has always been a feature of renowned quality both in materials, in finishes and in the composition of the furniture. The interesting duality that hides every piece of furniture allows it to adapt to more furnishings, giving value and difference at the same time. The living space of the houses, but also of the work areas, must allow the taste of those who live there and must express character, as it represents the environment in which most of the time is spent, and where guests are welcomed. If you love refined and contemporary style, but that knows how to look with style and passion at the classic, we offer you a wide choice of cupboards and beliefs able to marry design at best in search of materials, turning into reality those that are your tastes of style. The cupboards present in the catalog are the emblem of the union between modernity and functionality that flows into Italian Design, a furnishing principle that sees the homogeneous fusion between ideal and concreteness, a ratio of weights able to wrap the rooms creating a distinct character and recognizable. The harmony of construction and the high quality of the materials blend well with the timeless colors of quality wood, capable of infusing warmth and conveying pleasant sensations of comfort and serenity. The fascinating nuances of modern sideboards blend well with modular living room furniture.

cupboard design
contemporary



le Madie

madie
tavolini
specchiere

cupboard design
contemporary



le Madie





le Madie

cupboard design
contemporary

articolo **3150**
madia in TANGANICA 3 porte
con gamba in vetro. 3 doors cupboard
TANGANYIKA WOOD with glass leg.
cm. l. 189 p. 48 h. 65+13



La madia di design è un must per chi desidera aggiungere un tocco di raffinatezza alla propria casa. Le madie contemporanee combinano praticità tradizionale a forme eleganti, per creare un punto di arricchimento e decoro in diversi ambienti. In ingresso, la madia può essere un'idea originale e funzionale per mantenere sempre in ordine borse e accessori. In soggiorno, la credenza può trovare collocazione in ogni punto, anche al centro della stanza, oppure ravvivare una parete e fungere anche da madia porta TV.

The designer cupboard is a must for those who want to add a touch of refinement to their home. Contemporary cupboard combine traditional practicality with elegant shapes, to create a point of enrichment and decoration in different environments. In the entrance, the sideboard can be an original and functional idea for always keeping bags and accessories in order. In the living room, the sideboard can be placed anywhere, even in the center of the room, or it can live up a wall and also act as a TV cupboard.



le Madie →

cupboard design
contemporary

articolo **3151**
madia in FRASSINO 4 porte
con piedino in metallo. 4 doors cupboard
in ASH WOOD with metal leg.
cm. l. 126 p. 48 h. 66+17

articolo **3152**
porta TV in FRASSINO 1 porta 1 ribalta
con piedino in metallo. TV stand in ASH
WOOD 1 door 1 flap door with metal leg.
cm. l. 143 p. 48 h. 45+17

articolo **3153**
madia in FRASSINO 6 porte
con piedino in metallo. 6 doors cupboard
in ASH WOOD with metal leg.
cm. l. 189 p. 48 h. 66+17

le Madie

cupboard design
contemporary



MADIE CONTEMPORANEE DI DESIGN, una soluzione elegante e moderna legata alla tradizione. Di umili origini ma comunque presente sia nelle abitazioni lussuose che in quelle più rustiche di campagna, la madia è stata per lungo tempo uno dei mobili più apprezzati della casa: la sua versatilità e utilità, infatti, era accompagnata da un aspetto piacevole, perfetto per ogni ambiente.

CONTEMPORARY DESIGN CUPBOARD, an elegant and modern solution linked to tradition. Of humble origins but still present in both luxurious and more rustic country homes, the cupboard has long been one of the most popular pieces of furniture in the home: its versatility and usefulness, in fact, was accompanied by a pleasant appearance, perfect for every environment.



articolo **3153**
madia 6 porte in FRASSINO
con piedino in metallo. 6 doors cupboard
in ASH WOOD with metal leg.
cm. l. 189 p. 48 h. 66+17



articolo **3154**
madia in FRASSINO 4 porte 3 cassetti
con guide ammortizzate e piedino in metallo.
ASH WOOD sideboard with 4 doors and
3 drawers with soft closing and metal leg.
cm. l. 189 p. 48 h. 66+17

articolo **3157**
madia 3 porte rigate in FRASSINO
con piedino in metallo. 3 lined doors cupboard
in ASH WOOD with metal leg.
cm. l. 191 p. 49 h. 65+17



articolo **3159**
tavolino rotondo rigato basso
in FRASSINO. low round lined
coffee table in ASH WOOD.
cm. ø. 80 h. 45



articolo **3163**
tavolino rotondo rigato alto
in FRASSINO. high round lined
coffee table in ASH WOOD.
cm. ø. 50 h. 70



le Madie

cupboard design
contemporary



disponibile su misura.
available by custom.



Entrata

mirrors furniture
classic design

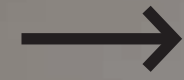

articolo **3291**
specchiera con cornice rigata
e contenitore interno. mirror with striped
frame and internal container.
cm. l. 102 p. 40 h. 162



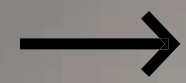

le Madie

cupboard design
contemporary



Interamente realizzate in Italia secondo tradizione, queste madie moderne in legno sono perfette per arredare qualsiasi ambiente grazie alla modernità del design che le caratterizza. Partendo dall'esigenza di sviluppare madie moderne dove poter riporre con estrema semplicità i propri oggetti, abbiamo studiato soluzioni in grado non solo soddisfare questa esigenza primaria, ma anche di deliziare lo sguardo grazie a un'estetica di design dalle linee pulite e assolutamente contemporanee.

Entirely made in Italy according to tradition, these modern wooden sideboards are perfect for furnishing any environment thanks to the modernity of the design that characterizes them. Starting from the need to develop modern cupboards where you can store your objects with extreme simplicity, we have studied solutions capable not only of satisfying this primary need, but also of delighting the eye thanks to a design aesthetic with clean and absolutely contemporary lines.



articolo **3158**
madia 3 porte rigate in FRASSINO
con piedino in metallo. 3 lined doors cupboard
in ASH WOOD with metal leg.
cm. l. 191 p. 49 h. 65+17



L'interessante dualità che nasconde ogni mobile permette di adattarsi a più arredamenti dando valore e differenza allo stesso tempo. Lo spazio living delle abitazioni, ma anche delle zone lavoro, deve lasciar trasparire il gusto di chi ci abita e deve esprimere carattere, poiché rappresenta l'ambiente in cui si passa la maggior parte del tempo, e dove si accolgono gli ospiti. Se ami lo stile raffinato e contemporaneo, ma che sa guardare con stile e passione al classico, ti offriamo un'ampia scelta di madie e credenze capaci di sposare al meglio il design alla ricerca dei materiali, trasformando in realtà quelli che sono i tuoi gusti di stile. Le madie presenti in catalogo sono l'emblema del connubio tra modernità e funzionalità che sfocia nell'Italian Design, un principio di arredo che vede la fusione omogenea tra ideale e concretezza, un rapporto di pesi in grado di avvolgere gli ambienti creando un carattere distinto e riconoscibile. L'armonia di costruzione e l'alta qualità dei materiali bene si sposano con i colori senza tempo del legno di qualità, capaci di infondere calore e trasmettere piacevoli sensazioni di comfort e serenità.

The interesting duality that hides every piece of furniture allows it to adapt to more furnishings, giving value and difference at the same time. The living space of the houses, but also of the work areas, must allow the taste of those who live there and must express character, as it represents the environment in which most of the time is spent, and where guests are welcomed. If you love refined and contemporary style, but that knows how to look with style and passion at the classic, we offer you a wide choice of cupboards and beliefs able to marry design at best in search of materials, turning into reality those that are your tastes of style. The cupboards present in the catalog are the emblem of the union between modernity and functionality that flows into Italian Design, a furnishing principle that sees the homogeneous fusion between ideal and concreteness, a ratio of weights able to wrap the rooms creating a distinct character and recognizable. The harmony of construction and the high quality of the materials blend well with the timeless colors of quality wood, capable of infusing warmth and conveying pleasant sensations of comfort and serenity.

articolo 3155
porta TV 3 porte rigate in FRASSINO
gamba vetro. 3 lined doors TV stand
in ASH WOOD with glass leg.
cm. l. 166 p. 47 h. 43+17



articolo 3156
tavolino rettangolare rigato
con cassetto in FRASSINO. Lined rectangular
coffee table with drawer in ASH WOOD.
cm. l. 120 p. 70 h. 25

particolare cassetto del tavolino.
detail drawer of the table.



particolare con piano in vetro nero.
detail with black glass top.



articolo 3160
madia 2 porte rigate in FRASSINO
con gamba traforata in metallo.
2 lined doors cupboard in ASH WOOD
with metal perforated leg.
cm. l. 128 p. 49 h. 65+13

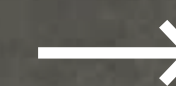

le Madie

cupboard design
contemporary



articolo **3161**
 madia 3 ante diamantate
 con profili in metallo dorato. 3 doors diamond
 cupboard with golden metal profiles.
 cm. l. 205 p. 45 h. 84



le Madie

cupboard design
contemporary

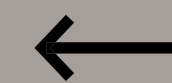

articolo **3162**
 madia 2 ante diamantate
 con profili in metallo dorato. 2 doors diamond
 cupboard with golden metal profiles.
 cm. l. 142 p. 45 h. 84



le Madie

cupboard design
contemporary



Italiancollectionscupboard 20



articolo 2111
madia in FRASSINO 3 ante 3 cassetti con guide
ammortizzate e basamento intrecciato.
3 doors cupboard in ASH WOOD 3 drawers
with soft closing and braided base.
cm. l. 209 p. 55 h. 98,5



21 Italiancollectionscupboard



anta pietra 1 stone door 1



anta pietra 2 stone door 2



anta rilievo argento silver relief door



pannelli disponibili
available panels



anta bricola bricola door



anta tridimensionale tridimensional door



pedini disponibili
available legs



metallo gray black.
gray black color metal.



basamento intrecciato. braided base. cm. h. 13



gamba traforata. perforated leg. cm. h. 13



pedino acciaio. steel leg. cm. h. 17



pedino metallo. metal leg. cm. h 17.



gamba vetro. glass leg. cm. h 17.



gamba dritta acciaio. steel straight leg. cm. h. 13



gamba slitta. slide leg. cm. h. 9



basamento legno. wood base. cm. h. 6

Italiancollectionscupboard 22



traforo tetris tetris perforated

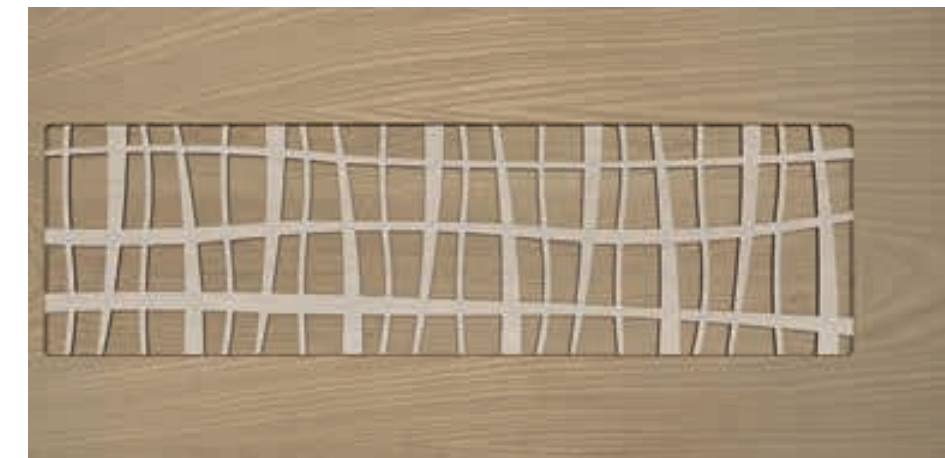

traforo natura nature perforated



trafori disponibili
available perforated



traforo letter letter perforated

articolo 2111/Z
madia in FRASSINO 3 ante 3 cassetti
con guide ammortizzate e zoccolo.
3 doors cupboard in ASH WOOD 3 drawers
with soft closing and bases.
cm. l. 209 p. 55 h. 88



articolo 2110
madia in FRASSINO 2 ante 2 cassetti
con guide ammortizzate e basamento intrecciato.
2 doors cupboard in ASH WOOD 2 drawers
with soft closing and braided base.
cm. l. 146 p. 55 h. 98,5



articolo 2112
tavolino rettangolare in FRASSINO
piano con pannello decorato. rectangular coffee
in ASH WOOD with decorated panel top.
cm. l. 120 p. 80 h. 25

23 Italiancollectionscupboard



IL LEGNO È UN MATERIALE VIVO che si adatta nel tempo alle condizioni e situazioni, è un materiale pregiato e se antico porta con sé memorie del tempo trascorso. Il Legno antico con le sue venature, i colori e le sue caratteristiche uniche è in grado di evocare ricordi e suscitare emozioni come solo le cose autentiche e di qualità riescono a fare. Il legno antico di recupero non risulta meno resistente o duraturo del legno nuovo. Dovete sapere che il legno antico viene opportunamente pulito, schiodato, levigato e preparato per essere nuovamente utilizzato. Le caratteristiche rimangono dunque invariate rispetto ad un'essenza nuova.

WOOD IS A LIVING MATERIAL that adapts over time to conditions and situations, it is a precious material and if ancient it brings with it memories of the past. The ancient wood with its veins, colors and its unique characteristics is able to evoke memories and arouse emotions as only authentic and quality things can do. Reclaimed antique wood is no less resistant or durable than new wood. You should know that antique wood is properly cleaned, unplugged, sanded and prepared to be used again. The characteristics therefore remain unchanged with respect to a new essence.

articolo **302**
madia 3 ante tridimensionali
con piedino acciaio. 4 three-dimensional
doors cupboard with steel leg.
cm. l. 189 p. 47 h. 63+17



le Madie

cupboard design
contemporary



articolo 300
madia intagliata 2 ante
con gamba traforata. 2 doors carving
 cupboard with perforated leg.
 cm. l. 120 p. 45 h. 60+13

Le nostre madie moderne uniscono design contemporaneo ed eleganza, realizzate con materiali di alta qualità come il frassino. Le madie in legno massiccio sono mobili senza tempo che si trovano in molti soggiorni, sale da pranzo e ingressi. Offrono uno spazio di archiviazione supplementare e contribuiscono a creare un punto focale nella stanza. Il legno massiccio è noto per la sua durata, bellezza e calore e rappresenta quindi la scelta ideale per realizzare una madia legno massello che duri nel tempo per molti anni a venire.

Our modern cupboard combine contemporary design and elegance, made with high quality materials such as ash. Solid wood cupboard are timeless pieces of furniture found in many living rooms, dining rooms and entryways. They offer additional storage space and help create a focal point in the room. Solid wood is known for its durability, beauty and warmth and therefore represents the ideal choice for creating a solid wood sideboard that will last for many years to come.



articolo 301
madia intagliata 3 ante
con gamba dritta acciaio. 3 doors carving
 cupboard with straight leg steel.
 cm. l. 180 p. 45 h. 60+13



le Madie

cupboard design
contemporary





articolo **307**
 madia 2 ante effetto pietra 2
 basamento legno. 2 doors stone effect
 2 cupboard wood basement.
 cm. l. 142 p. 45 h. 79+6



le Madie

cupboard design
 contemporary



articolo **308**
 madia 3 ante rilievo argento
 con gamba slitta. 4 silver relief
 doors cupboard with sled leg.
 cm. l. 205 p. 45 h. 79+9





articolo **311**
 madia 3 ante a sbalzo
 con piedino acciaio. 3 high low
 doors cupboard with steel leg.
 cm. l. 194 p. 45 h. 63+17



articolo **315**
 madia 3 ante battenti
 con intagli. 3 hinged doors
 cupboard with carvings.
 cm. l. 205 p. 45 h. 89



articolo **303**
 madia 2 ante a sbalzo gamba
 dritta acciaio. 2 high low doors
 cupboard straight leg steel.
 cm. l. 126 p. 45 h. 63+13



italiancollectionscupboard 30

le Madie

cupboard design
 contemporary



articolo **312**
 madia 2 ante decoro.
 2 doors decor cupboard.
 cm. l. 142 p. 45 h. 89



31 Italiancollectionscupboard

cupboard design contemporary

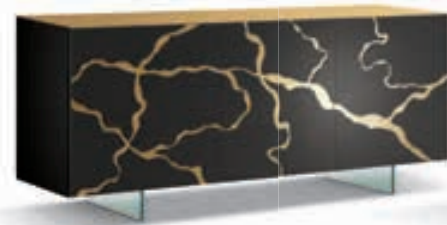

articolo 3150
 madia 3 ante. 3 doors cupboard.
 cm. l. 189 p. 48 h. 65+13



articolo 3157
 madia 3 ante. 3 doors cupboard.
 cm. l. 191 p. 49 h. 65+17



articolo 3160
 madia 2 ante. 2 doors cupboard.
 cm. l. 128 p. 49 h. 65+13



articolo 3155
 porta TV 3 ante. 3 doors TV stand.
 cm. l. 166 p. 47 h. 43+17



articolo 2111
 madia 3 ante. 3 doors cupboard.
 cm. l. 209 p. 55 h. 98,5

articolo 2110
 madia 2 ante. 2 doors cupboard.
 cm. l. 146 p. 55 h. 98,5



articolo 2111/Z
 madia 3 ante. 3 doors cupboard.
 cm. l. 209 p. 55 h. 88

articolo 2110/Z
 madia 2 ante. 2 doors cupboard.
 cm. l. 209 p. 55 h. 88



articolo 3154
 madia 4 ante 3 cassetti. 4 doors cupboard
 3 drawers. cm. l. 189 p. 45 h. 63+17



articolo 3153
 madia 6 ante. 6 doors cupboard.
 cm. l. 189 p. 47 h. 63+17



articolo 3151
 madia 4 ante. 4 doors cupboard.
 cm. l. 126 p. 47 h. 63+17



articolo 3152
 porta TV 1 anta 1 ribalta. TV stand 1 door
 1 flap door. cm. l. 143 p. 48 h. 45+17



articolo 302
 madia 3 ante. 3 doors cupboard.
 cm. l. 189 p. 47 h. 63+17



articolo 307
 madia 2 ante. 2 doors cupboard.
 cm. l. 142 p. 45 h. 79+6



articolo 308
 madia 3 ante. 3 doors cupboard.
 cm. l. 205 p. 45 h. 79+9



articolo 303
 madia 2 ante. 2 doors cupboard.
 cm. l. 126 p. 45 h. 63+13



articolo 3161
 madia 3 ante. 3 doors cupboard.
 cm. l. 205 p. 45 h. 84



articolo 3162
 madia 2 ante. 2 doors cupboard.
 cm. l. 142 p. 45 h. 84



articolo 300
 madia 2 ante. 2 doors cupboard.
 cm. l. 120 p. 45 h. 60+13



articolo 301
 madia 3 ante. 3 doors cupboard.
 cm. l. 180 p. 45 h. 60+13



articolo 311
 madia 3 ante. 3 doors cupboard.
 cm. l. 193 p. 45 h. 63+17



articolo 312
 madia 2 ante. 2 doors cupboard.
 cm. l. 142 p. 45 h. 89



articolo 315
 madia 3 ante. 3 doors cupboard.
 cm. l. 205 p. 45 h. 89



metallo gray black.
 gray black color metal.



pedini disponibili available legs

L'attenzione ai dettagli è massima, e proprio per questo non trascuriamo importanti particolari come i piedi, che sostengono l'intera struttura, realizzati in materiali inossidabili.

Attention to detail is maximum, and precisely for this reason it does not leave out important details such as the feet, which support the entire structure, made of stainless materials.



basamento legno. wood base. cm. h. 6



gamba slitta. slide leg. cm. h. 9



gamba traforata. perforated leg. cm. h. 13



pedino acciaio. steel leg. cm. h. 17

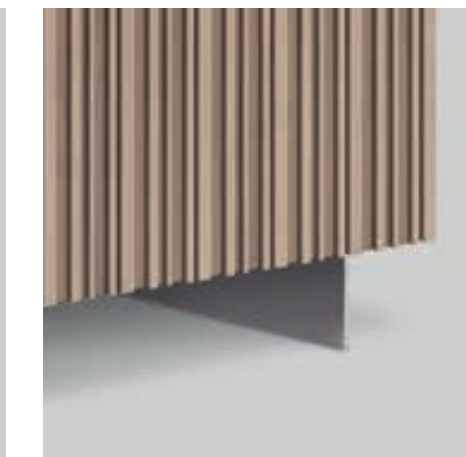

gamba dritta acciaio. steel straight leg. cm. h. 13

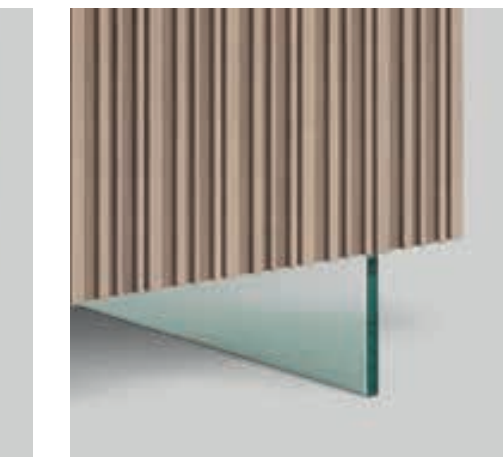

gamba vetro. glass leg. cm. h. 17.



pedino metallo. metal leg. cm. h. 17.

living room design
contemporary



le Pareti

Le nostre pareti attrezzate contemporanee sono strutture componibili che arredano interi ambienti, espletando le più svariate funzioni. Ogni parete attrezzata è realizzata su misura a partire da singoli moduli, assemblati in modo da creare diversi disegni che si adattano allo spazio e alla zona giorno: strutture sospese, poggianti a terra, ad angolo. Le pareti attrezzate assolvono ad una combinazione di funzioni: contenitori di stoviglie e accessori per la casa, oggettistica, librerie, spazi multimediali. Esse vengono pensate e organizzate in base alle esigenze del cliente e progettate su misura utilizzando il frassino. Il legno di frassino ha la principale caratteristica di essere molto elastico e flessibile, tanto da renderlo il più robusto e resistente fra i legni prodotti in europa. Ogni nostra creazione è unica, composizioni studiate secondo criteri di estrema eleganza e personalizzazioni di altissimo pregio rendono ogni progetto un'opera d'arte, capace di supportare ogni esigenza di contenimento, esposizione, funzionalità.

Our contemporary equipped walls are modular structures that furnish entire rooms, performing the most varied functions. Each equipped wall is made to measure starting from single modules, assembled to create different designs that adapt to the space and the living area: suspended structures, resting on the ground, at an angle. The equipped walls perform a combination of functions: containers of dishes and home accessories, objects, bookcases, multimedia spaces. They are conceived and organized according to the customer's needs and custom-made using the ash. Ash wood has the main characteristic of being very elastic and flexible, so as to make it the most robust and resistant among the woods produced in Europe. Each of our creations is unique, compositions studied according to criteria of extreme elegance and high-quality customizations make each project a work of art, capable of supporting any need for containment, display, functionality.

living room design
contemporary



le Pareti

divisori
pareti componibili
tavolini
pareti fisse
librerie
zona studio



articolo **MURANO**
parete componibile in FRASSINO
montanti in metallo, modular living room
in ASH WOOD metal uprights.
cm. l. 544 p. 40 h. variabile

living room design
contemporary

Murano →



articolo **SANT'ANDREA**
parete componibile in FRASSINO
montanti in metallo, modular living room
in ASH WOOD metal uprights.
cm. l. 394 p. 40 h. variabile

Librerie e ripiani sono componenti essenziali di qualsiasi spazio, dato il valore estetico e funzionale che possono conferire a un ambiente. Le librerie di design non hanno la sola funzione di contenere libri e oggetti, ma contribuiscono anche a definire l'atmosfera generale di uno spazio. Una libreria moderna e ben progettata può aggiungere profondità e colore a uno spazio, creando al contempo un senso di calore e comfort. Da un punto di vista pratico, le librerie servono a organizzare ed esporre i propri oggetti, facilitando l'accesso ai materiali di cui si ha bisogno. Possono anche essere utilizzate per esporre opere d'arte e altri elementi personali, dando un tocco di personalità e carattere all'ambiente.

Bookcases and shelves are essential components of any space, given the aesthetic and functional value they can give to a room. Designer bookcases do not only have the function of containing books and objects, but also contribute to defining the general atmosphere of a space. A modern, well-designed bookcase can add depth and color to a space, while creating a sense of warmth and comfort. From a practical point of view, bookcases serve to organize and display your objects, facilitating access to the materials you need. They can also be used to display works of art and other personal items, giving a touch of personality and character to the space.

living room design
contemporary

Sant'Andrea →



articolo 3007
specchiera rettangolare in FRASSINO
specchio liscio, rectangular mirror in
ASH WOOD with smooth mirror.
cm. l. 130 sp. 3 h. 80

articolo 3157
madia 3 porte rigate in FRASSINO
con piedino in metallo, 3 lined doors cupboard
in ASH WOOD with metal leg.
cm. l. 191 p. 49 h. 65+17

← Sant'Andrea

living room design
contemporary

LE PARETI

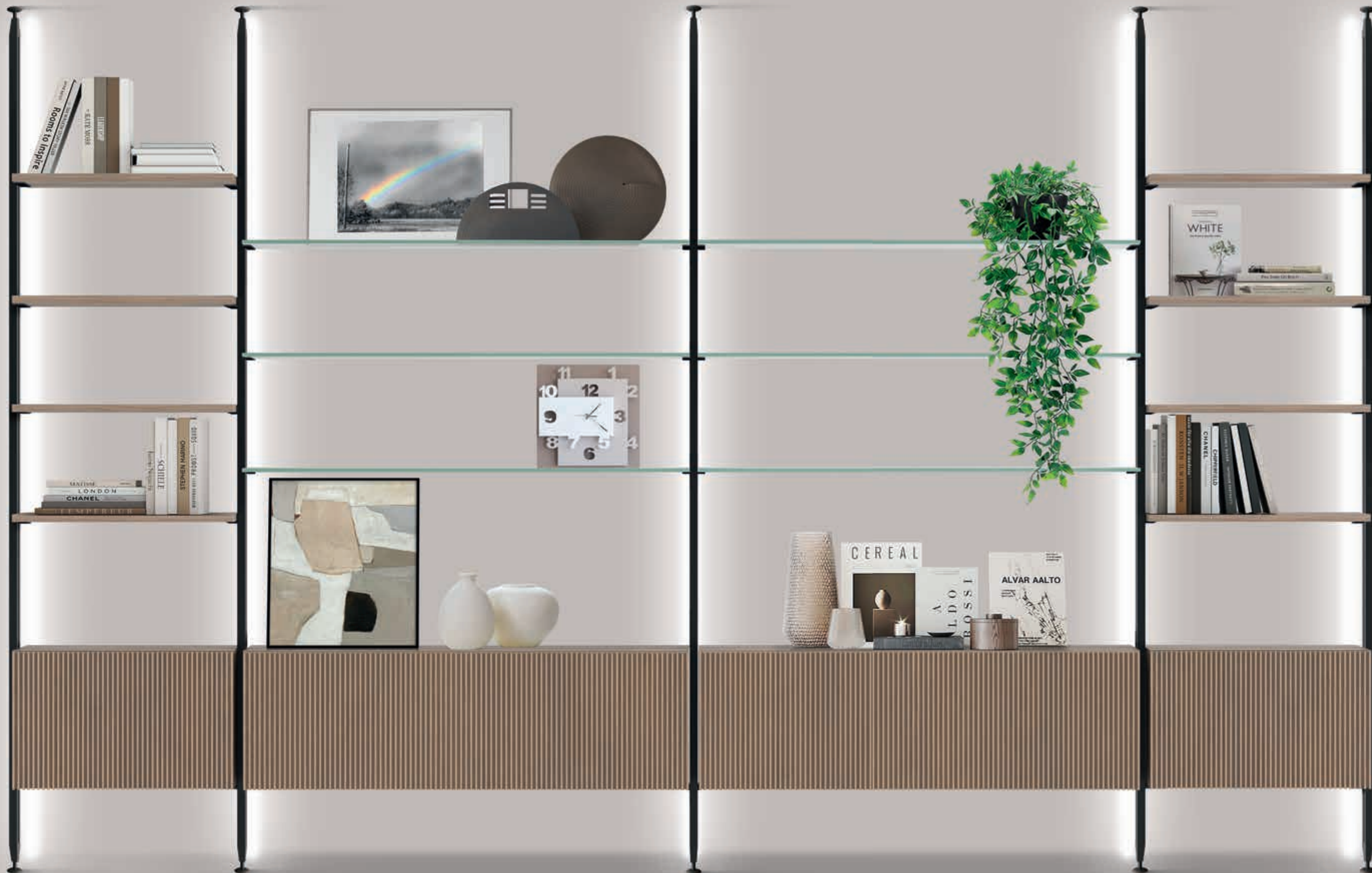

STRISCIE AL LED (OPTIONAL).
LED STRIPS (OPTIONAL).

STRISCIE AL LED Questa tipologia di illuminazione è interessante anche perché riesce a valorizzare i particolari di una stanza e gli arredi di design. Inoltre, è la soluzione ideale negli spazi piccoli, dove altre tipologie di illuminazione risulterebbero invasive e ingombranti. Le strisce a Led sono anche molto scenografiche perché permettono di creare particolari effetti luminosi.

LED STRIPS This type of lighting is also interesting because it manages to enhance the details of a room and the designer furnishings. Furthermore, it is the ideal solution in small spaces, where other types of lighting would be invasive and cumbersome. LED strips are also very scenic because they allow you to create particular lighting effects.



living room design
contemporary

Burano

articolo **BURANO**
parete componibile in FRASSINO
montanti in metallo. modular living room
in ASH WOOD metal uprights.
cm. l. 396 p. 40 h. variabile



articolo **LIBRERIE**
parete componibile in FRASSINO
montanti in metallo. modular living room
in ASH WOOD metal uprights.

Libreria

living room design
contemporary



articolo **4053**
coppia supporti paletti.
pair of pole supports.



articolo **4054**
coppia supporti per cassetti.
pair of drawer supports.



articolo **4055**
coppia supporti per mensole legno.
pair of supports for wooden shelves.

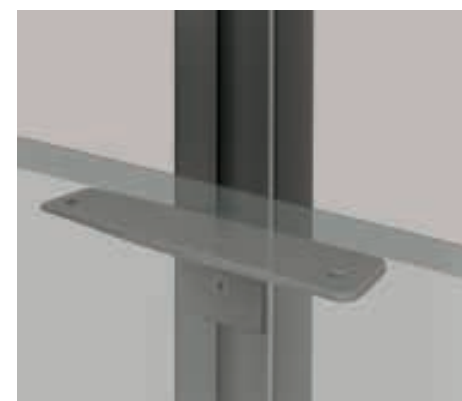

articolo **4056**
coppia supporti per mensole vetro.
pair of supports for glass shelves.



articolo **4057**
luci al led.
led lights.



articolo **4058**
palo porta abiti in alluminio.
aluminum clothes pole.



luci al led da inserire nella parte posteriore del montante. led lights to be inserted in the rear part of the upright.

sistema componibile modular system

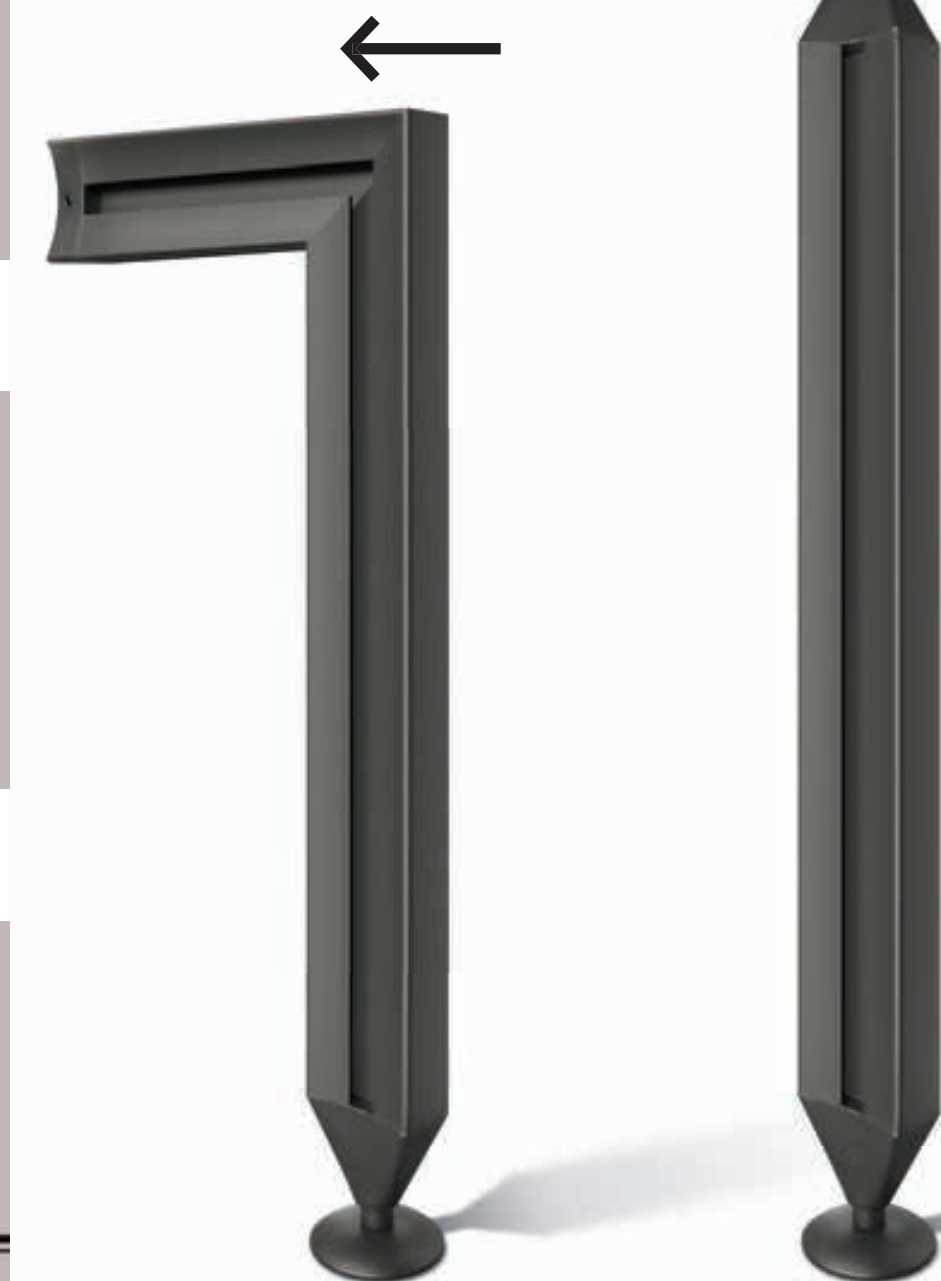

articolo **4051**
montante in metallo con piedino
parte finale per fissaggio a muro.
metal upright with final foot for wall
fixing. cm. h. 260

articolo **4052**
montante in metallo con piedino
parte finale per fissaggio a soffitto.
metal upright with foot final part for ceiling
fixing. cm. h. max 300

Progettiamo soluzioni d'arredo al servizio dell'ergonomia e della funzione. Librerie Modulari, realizzate con materiali innovativi ed eco-compatibili. Sospese, a parete o a centro stanza: le librerie di design donano personalità e carattere al soggiorno. Tante soluzioni di arredo su misura, allineate o disallineate, da progettare come vuoi tu, per una grande libertà di composizione. Caratteristico design minimal e contemporaneo, ideale in ogni ambiente, dalla zona giorno alla zona notte rendendo ogni locale semplicemente impeccabile. La struttura modulare permette di creare infinite combinazioni sviluppabili orizzontalmente o verticalmente per coprire qualsiasi tipo di spazio.

We design furnishing solutions at the service of ergonomics and function. Modular bookcases, made with innovative and eco-compatible materials. Suspended, on the wall or in the center of the room: designer bookcases give personality and character to the living room. Many tailor-made furnishing solutions, aligned or misaligned, to be designed as you want, for great freedom of composition. Characteristic minimal and contemporary design, ideal in any environment, from the living area to the sleeping area, making every room simply impeccable. The modular structure allows you to create infinite combinations that can be developed horizontally or vertically to cover any type of space.

montante con scanalatura sul retro per inserimento strisce a led (OPTIONAL).
upright with groove on the back for inserting LED strips (OPTIONAL)

i pali in metallo si possono utilizzare con tutti gli elementi presenti sul catalogo. →
 the metal poles can be used with all the elements present in the catalogue.



Programma componibile dalla flessibilità totale. Ogni realizzazione risulta essere unica in quanto progettata a misura ed arricchita con infinite possibilità di finiture e decori. Frutto di una ricerca continua sui temi della decorazione e del colore. Massima libertà per configurazioni di librerie ad andamento orizzontale o verticale, per spalle e ripiani di spessore diverso, per zone di contenimento con anta vasistas, o cassettoni, pensili a giorno e mensole. Le librerie sono anche integrabili con tutti i contenitori della collezione Anthologia 2.4. Tutti i moduli della collezione sono rigorosamente in legno massello. Declinabili l'un l'altro, sono capaci di creare spazi attrezzati su misura. L'estrema modularità permette una progettazione personalizzata al massimo, capace di rispondere ad ogni esigenza del cliente. La varietà di materiali e finiture che compongono ciascun modulo consente un'ampia gamma di abbinamenti cromatici. La collezione è completamente disassemblabile. Una collezione completa, pensata per dare ampia risposta in termini funzionali e dimensionali. Si concentra sulla praticità d'utilizzo e sul tema del contenimento. La sua immagine senza tempo è in grado di adattarsi perfettamente ad ogni ambiente.

Modular program with total flexibility. Each creation is unique as it is custom-designed and enriched with infinite possibilities of finishes and decorations. The result of continuous research on the themes of decoration and color. Maximum freedom for configurations of horizontal or vertical bookcases, for sides and shelves of different thicknesses, for storage areas with hinged doors, or drawers, open wall units and shelves. The bookcases can also be integrated with all the containers from the Anthologia 2.4 collection. All the modules in the collection are strictly made of solid wood. Declinable from one another, they are capable of creating tailor-made equipped spaces. The extreme modularity allows for highly personalized design, capable of responding to every customer need. The variety of materials and finishes that make up each module allows for a wide range of color combinations. The collection can be completely disassembled. A complete collection, designed to provide a broad response in functional and dimensional terms. It focuses on practicality of use and the theme of containment. Its timeless image is able to adapt perfectly to any environment.

**sistema componibile
 modular system**



articolo **ELBA**
soggiorno componibile in FRASSINO.
modular living room in ASH WOOD.
cm. l. 315 p. 55

Elba

living room design
contemporary



LE PARETI

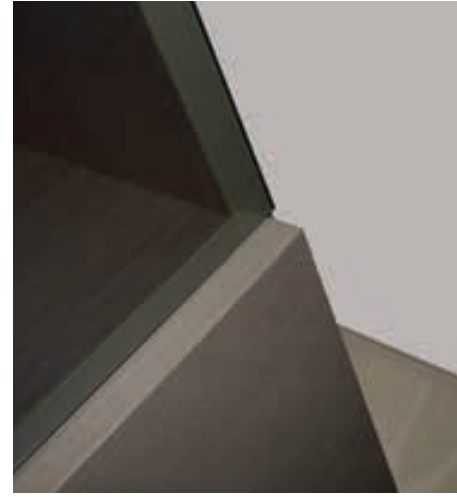

articolo **FAVIGNANA**
 soggiorno componibile in FRASSINO.
 modular living room in ASH WOOD.
 cm. l. 335 p. 55 h. 212

L'estrema componibilità permette di arredare soggiorni o salotti di design rispondendo ad ogni tipo di esigenza di stile e spazio. Grazie alla loro flessibilità progettuale, pareti attrezzate per soggiorno, librerie di design danno forma alla casa che volete Voi. Infinite forme e geometrie danno vita a pareti attrezzate moderne per la zona giorno, sospese o a terra, personalizzabili in legno, vetro o laccato, le pareti attrezzate permettono massima libertà compositiva, per realizzare soluzioni innovative.

The extreme modularity allows you to furnish designer living rooms or lounges, responding to every type of style and space requirement. Thanks to their design flexibility, equipped walls for the living room and designer bookcases give shape to the home you want. Infinite shapes and geometries give life to modern equipped walls for the living area, suspended or on the floor, customizable in wood, glass or lacquered, the equipped walls allow maximum compositional freedom, to create innovative solutions.

living room design
 contemporary

Favignana →



Capri

living room design
contemporary

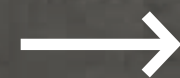

articolo **CAPRI**
soggiorno componibile in FRASSINO.
modular living room in ASH WOOD.
cm. l. 315 p. 55



LE PARETI



Lipari

living room design
contemporary

articolo **LIPARI**
soggiorno componibile in FRASSINO.
modular living room in ASH WOOD.
cm. l. 335 p. 55 h. 212

Ischia

living room design
contemporary

articolo **ISCHIA**
soggiorno componibile in FRASSINO.
modular living room in ASH WOOD.
cm. l. 362 p. 55 h. 217

LE PARETI



Linosa

articolo **LINOSA**
 soggiorno componibile in FRASSINO.
 modular living room in ASH WOOD.
 cm. l. 252 p. 55

living room design
 contemporary



Le pareti attrezzate su misura rispondono alle esigenze di versatilità degli spazi contemporanei. Sono sistemi pensati per contenere e nascondere tutti i collegamenti senza inficiare sul design moderno. Le pareti attrezzate hanno un grande vantaggio: permettono di sfruttare lo spazio verticalmente o orizzontalmente, riducendo gli ingombri e lasciando libere le superfici. Sono soluzioni versatili, modulari, che consentono di personalizzare sia le funzionalità sia le linee, i colori, lo stile, l'alternanza tra spazio pieno e vuoto. Se vivi in spazi piccoli o hai a disposizione pochi metri quadri è meglio evitare soluzioni eccessivamente profonde. Maggior spazio invece consente di giocare con grandi volumi. Con le nostre soluzioni puoi scegliere la larghezza dei moduli, l'altezza e la profondità dei componenti, al fine di ottenere un risultato al tempo efficiente ed esteticamente adeguato alle tue esigenze ed aspettative. Realizzate artigianalmente in Italia, con materiali di qualità e finiture di pregio. La collezione offre svariate soluzioni di design e composizioni per arredare un salotto dallo stile classico, moderno o contemporaneo. Possibilità di personalizzare sia i colori e le finiture sia le composizioni.



articolo **PONZA**
 soggiorno componibile in FRASSINO.
 modular living room in ASH WOOD.
 cm. l. 252 p. 55

↑ Ponza

living room design
 contemporary

The custom-equipped walls respond to the versatility needs of contemporary spaces. They are systems designed to contain and hide all connections without affecting the modern design. Equipped walls have a great advantage: they allow you to exploit the space vertically or horizontally, reducing overall dimensions and leaving surfaces free. They are versatile, modular solutions that allow you to customize both the functionality and the lines, colors, style, alternation between full and empty space. If you live in small spaces or have a few square meters available, it is better to avoid excessively deep solutions. More space instead allows you to play with large volumes. With our solutions you can choose the width of the modules, the height and depth of the components, in order to obtain a result that is both efficient and aesthetically suited to your needs and expectations. Handcrafted in Italy, with quality materials and fine finishes. The collection offers various design solutions and compositions to furnish a living room with a classic, modern or contemporary style. Possibility to customize both the colors and finishes and the compositions.



← Procida

living room design
contemporary

articolo **PROCIDA**
soggiorno componibile in FRASSINO.
modular living room in ASH WOOD.
cm. l. 293 p. 55

articolo **CAPRERA**
soggiorno componibile in FRASSINO.
modular living room in ASH WOOD.
cm. l. 315 p. 55

Caprera →

living room design
contemporary



← **Ustica**
living room design
contemporary

Con le nostre soluzioni puoi scegliere la larghezza dei moduli, l'altezza e la profondità dei componenti, al fine di ottenere un risultato al contempo efficiente ed esteticamente adeguato alle tue esigenze ed aspettative. Realizzate artigianalmente in Italia, con materiali di qualità e finiture di pregio. La collezione offre svariate soluzioni di design e composizioni per arredare un salotto dallo stile classico, moderno o contemporaneo. Possibilità di personalizzare sia i colori e le finiture sia le composizioni.

With our solutions you can choose the width of the modules, the height and depth of the components, in order to obtain a result that is both efficient and aesthetically suited to your needs and expectations. Handcrafted in Italy, with quality materials and fine finishes. The collection offers various design solutions and compositions to furnish a living room with a classic, modern or contemporary style. Possibility to customize both the colors and finishes and the compositions.

articolo **USTICA**
soggiorno componibile in FRASSINO.
modular living room in ASH WOOD.
cm. l. 293 p. 55

articolo **3156**
tavolino rettangolare rigato
con cassetto in FRASSINO. Lined rectangular
coffee table with drawer in ASH WOOD.
cm. l. 120 p. 70 h. 25

articolo **GIGLIO**
 soggiorno componibile in FRASSINO.
 modular living room in ASH WOOD.
 cm. l. 315 p. 45

Giglio

living room design
 contemporary



sistema componibile modular system

→ elementi singoli per composizioni. individual elements for composition.

basi in FRASSINO con zoccolo. bases in ASH WOOD with plinth.



articolo **3065**
 base bassa corta 1 cassetto.
 short low base 1 drawers.
 cm. l. 63 p. 55 h. 25



articolo **3066**
 base alta corta 1 cestone.
 short high base 1 drawers.
 cm. l. 63 p. 55 h. 43,5



articolo **3067**
 base bassa lunga 1 cestone.
 long low base 1 drawers.
 cm. l. 90/126 p. 55 h. 25



articolo **3068**
 base alta lunga 1 cestone.
 long high base 1 drawers.
 cm. l. 90/126 p. 55 h. 43,5



articolo **3095**
 base bassa ad angolo con vano.
 corner low base with compart.
 cm. l. 90 p. 90 h. 25



articolo **3082**
 base 1 anta apertura battente.
 base 1 door opening hinged door.
 cm. l. 63 p. 55 h. 66,5



articolo **3083**
 base 1 anta apertura battente.
 base 1 door opening hinged door.
 cm. l. 63 p. 55 h. 66,5



articolo **3084**
 base 1 anta apertura battente.
 base 1 door opening hinged door.
 cm. l. 63 p. 55 h. 66,5



articolo **3090**
 base 1 anta apertura battente.
 base 1 door opening hinged door.
 cm. l. 63 p. 55 h. 66,5



articolo **3096**
 base alta ad angolo a giorno.
 corner high base with compart.
 cm. l. 90 p. 90 h. 43,5

inserti e pannelli con righe in FRASSINO per basi e pensili (specificare inserto A, B e C).
 inserts and panels with stripes in ASH WOOD for base and hanging (specify insert A, B and C).



articolo **3100/ins.**
 inserto basso per basi e pensili.
 low insert for bases and hanging.
 cm. l. 10 sp. 1 h. 22



articolo **3101/ins.**
 inserto alto per basi e pensili.
 high insert for bases and hanging.
 cm. l. 10 sp. 1 h. 40



articolo **3102/ins.**
 inserto basso corto per basi e pensili.
 short low insert for bases and hanging.
 cm. l. 63 sp. 1 h. 22



articolo **3103/ins.**
 inserto alto corto per basi e pensili.
 short high insert for bases and hanging.
 cm. l. 63 sp. 1 h. 40



articolo **3104/ins.**
 inserto basso lungo per basi e pensili.
 long low insert for bases and hanging.
 cm. l. 90/126 sp. 1 h. 22

basi sospese in FRASSINO. suspended bases in ASH WOOD.



articolo **3065/sosp.**
 base sospesa bassa corta 1 cassetto.
 short low suspended base 1 drawers.
 cm. l. 63 p. 37 h. 22



articolo **3066/sosp.**
 base sospesa alta corta 1 cestone.
 short high suspended base 1 drawers.
 cm. l. 63 p. 37 h. 40



articolo **3067/sosp.**
 base sospesa bassa lunga 1 cestone.
 long low suspended base 1 drawers.
 cm. l. 90/126 p. 37 h. 22



articolo **3068/sosp.**
 base sospesa alta lunga 1 cestone.
 long high suspended base 1 drawers.
 cm. l. 90/126 p. 37 h. 40



articolo **3105/ins.**
 inserto alto lungo per basi e pensili.
 high insert for bases and hanging.
 cm. l. 90/126 sp. 1 h. 40

pensili in FRASSINO profondità cm. 36,5 / 29,5 / 24,5. hanging in ASH WOOD depth cm. 36.5 / 29.5 / 24.5.



articolo **3064**
 pensile verticale porta vetro.
 1 glass door vertical hanging.
 cm. l. 40 p. da specificare h. 126



articolo **3051**
 pensile verticale 1 porta sinistra.
 1 leaf door vertical hanging.
 cm. l. 40 p. da specificare h. 126



articolo **3052**
 pensile verticale 1 porta destra.
 1 leaf door vertical hanging.
 cm. l. 40 p. da specificare h. 126



articolo **3053**
 pensile verticale 1 porta sinistra.
 1 leaf door vertical hanging.
 cm. l. 40 p. da specificare h. 126



articolo **3054**
 pensile verticale 1 porta destra.
 1 leaf door vertical hanging.
 cm. l. 40 p. da specificare h. 126

sistema componibile modular system

→ elementi singoli per composizioni. individual elements for composition.

pensili in FRASSINO profondità cm. 36,5 / 29,5 / 24,5. hanging in ASH WOOD depth cm. 36.5 / 29.5 / 24.5.



articolo **3089**
pensile orizzontale a giorno.
compartement horizontal hanging.
cm. l. 126 p. da specificare h. 40



articolo **3077**
pensile orizzontale 1 porta vasistas.
1 vasistas door horizontal hanging.
cm. l. 126 p. da specificare h. 40



articolo **3078**
pensile orizzontale 1 porta vasistas.
1 vasistas door horizontal hanging.
cm. l. 126 p. da specificare h. 40



articolo **3079**
pensile orizzontale 1 porta ribalta.
1 flap door horizontal hanging.
cm. l. 126 p. da specificare h. 40



articolo **3080**
pensile orizzontale 1 porta ribalta.
1 flap door horizontal hanging.
cm. l. 126 p. da specificare h. 126



articolo **3048**
pensile orizzontale a giorno.
compartement horizontal hanging.
cm. l. 189 p. da specificare h. 40



articolo **3049**
pensile orizzontale 3 vani a giorno.
horizontal hanging 3 compartement.
cm. l. 186 p. da specificare h. 40



articolo **3081**
pensile orizzontale porta e vano.
horizontal hanging door and compar.
cm. l. 189 p. da specificare h. 40



articolo **3063**
pensile orizzontale porta vasistas.
horizontal hanging vasistas door.
cm. l. 126 p. da specificare h. 40



articolo **3055**
pensile orizzontale a giorno.
horizontal compartement hanging.
cm. l. 126 p. da specificare h. 40



articolo **3056**
pensile 1 porta vetro sinistra.
1 glass leaf door hanging.
cm. l. 63 p. da specificare h. 63



articolo **3057**
pensile 1 porta vetro destra.
1 glass right door hanging.
cm. l. 63 p. da specificare h. 63



articolo **3058**
pensile a giorno.
compartement hanging.
cm. l. 63 p. da specificare h. 63



articolo **3069**
pensile 3 porte vetro destra o sinistra.
3 right or left glass doors hanging.
cm. l. 63 p. da specificare h. 120



articolo **3070**
pensile 2 porte destra o sinistra.
2 right or left doors hanging.
cm. l. 63 p. da specificare h. 126



articolo **3093**
pensile bassa ad angolo con vano.
corner low hanging with compartment.
cm. l. 90 p. 90 h. 20



articolo **3094**
pensile alta ad angolo a giorno.
corner high hanging with compartment.
cm. l. 90 p. 90 h. 40



articolo **3060**
pensile 1 porta vetro destra o sinistra.
1 right or left glass door hanging.
cm. l. 63 p. da specificare h. 63



articolo **3062**
pensile orizzontale 2 porte vetro.
2 glass doors horizontal hanging.
cm. l. 126 p. da specificare h. 63



articolo **3061**
pensile 2 porte vetro destra o sinistra.
2 right or left glass doors hanging.
cm. l. 63 p. da specificare h. 126



articolo **3085**
pensile 1 anta apertura ribalta.
hanging 1 door opening flap door.
cm. l. 63 p. da specificare h. 63



articolo **3086**
pensile 1 anta apertura ribalta.
hanging 1 door opening flap door.
cm. l. 63 p. da specificare h. 63



articolo **3087**
pensile 1 anta apertura vasistas.
hanging 1 door vasistas opening.
cm. l. 63 p. da specificare h. 63



articolo **3088**
pensile 1 anta apertura vasistas.
hanging 1 door vasistas opening.
cm. l. 63 p. da specificare h. 63

colonne. columns.



articolo **3075**
colonna 3 ante vetro.
3 glass door column.
cm. l. 63 p. 36,5 h. 192

mensole con segreto. shelves with secret.



articolo **3076**
mensola apribile con segreto.
openable shelf with secret.
cm. l. 189 p. 46 sp. 8

mensole. shelves.



articolo **3072**
mensola cm. 63. shelf 63 cm.
cm. l. 63 p. da specificare sp. 3



articolo **3073**
mensola cm. 126. shelf 126 cm.
cm. l. 90/126 p. da specificare sp. 3



articolo **3074**
mensola cm. 189. shelf 189 cm.
cm. l. 189 p. da specificare sp. 3

sistema componibile modular system



schienali boiserie con righe al metro lineare. backs boiserie with stripes per linear metre.

articolo **3071**
Boiserie con righe.
Boiserie with stripes.
specificare A,B o C.

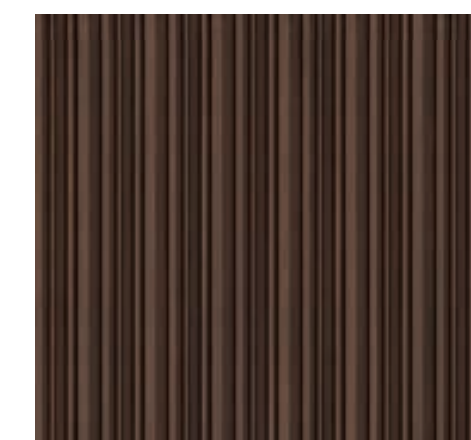
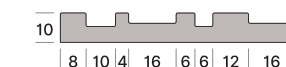

A ANTA RIGHE. STRIPED DOOR.

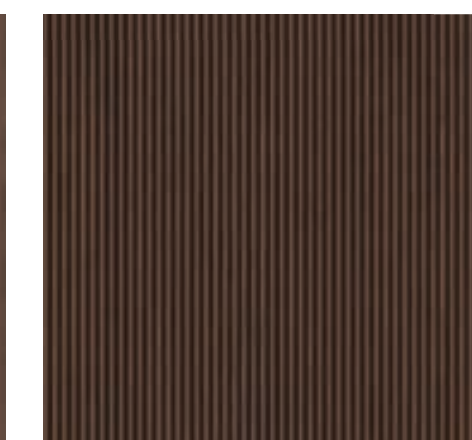

B ANTA RIGHE. STRIPED DOOR.

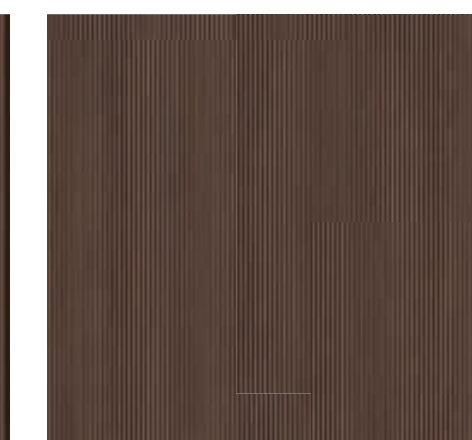

C ANTA RIGHE. STRIPED DOOR.





living room design
contemporary



le Pareti

Le nostre pareti attrezzate contemporanee sono strutture componibili che arredano interi ambienti, espletando le più svariate funzioni. Ogni parete attrezzata è realizzata su misura a partire da singoli moduli, assemblati in modo da creare diversi disegni che si adattano allo spazio e alla zona giorno: strutture sospese, poggianti a terra, ad angolo. Le pareti attrezzate assolvono ad una combinazione di funzioni: contenitori di stoviglie e accessori per la casa, oggettistica, librerie, spazi multimediali. Esse vengono pensate e organizzate in base alle esigenze del cliente e progettate su misura utilizzando il frassino. Il legno di frassino ha la principale caratteristica di essere molto elastico e flessibile, tanto da renderlo il più robusto e resistente fra i legni prodotti in europa. Ogni nostra creazione è unica, composizioni studiate secondo criteri di estrema eleganza e personalizzazioni di altissimo pregio rendono ogni progetto un'opera d'arte, capace di supportare ogni esigenza di contenimento, esposizione, funzionalità.

Our contemporary equipped walls are modular structures that furnish entire rooms, performing the most varied functions. Each equipped wall is made to measure starting from single modules, assembled to create different designs that adapt to the space and the living area: suspended structures, resting on the ground, at an angle. The equipped walls perform a combination of functions: containers of dishes and home accessories, objects, bookcases, multimedia spaces. They are conceived and organized according to the customer's needs and custom-made using the ash. Ash wood has the main characteristic of being very elastic and flexible, so as to make it the most robust and resistant among the woods produced in Europe. Each of our creations is unique, compositions studied according to criteria of extreme elegance and high-quality customizations make each project a work of art, capable of supporting any need for containment, display, functionality.



articolo **AIDA**
soggiorno componibile in FRASSINO.
modular living room in ASH WOOD.
cm. l. 286 p. 55 h. 226

articolo **2111**
madia 3 ante 3 cassetti in FRASSINO
con basamento intrecciato. 3 doors cupboard
3 drawers in ASH WOOD with braided base.
cm. l. 209 p. 55 h. 98,5

articolo **2112**
tavolino rettangolare in FRASSINO piano
con pannello decorato. rectangular coffee
in ASH WOOD with decorated panel top.
cm. l. 120 p. 80 h. 25

Aida

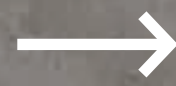

living room design
contemporary



living room design
contemporary

Allegra

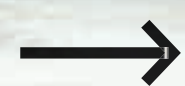

articolo **ALLEGRA**
soggiorno componibile in FRASSINO.
modular living room in ASH WOOD.
cm. l. 315 p. 23,5/36,5/55



LE PARETI

articolo **ZOE**
soggiorno componibile in FRASSINO.
modular living room in ASH WOOD.
cm. l. 315 p. 55



Zoe

living room design
contemporary

LE PARETI

Clizia

living room design
contemporary



articolo **CLIZIA**
soggiorno componibile in FRASSINO.
modular living room in ASH WOOD.
cm. l. 292 p. 50



LE PARETI



Mila

articolo **MILA**
 soggiorno componibile in FRASSINO.
 modular living room in ASH WOOD.
 cm. l. 252 p. 50

living room design
 contemporary



Le nostre pareti attrezzate contemporanee sono strutture componibili che arredano interi ambienti, espletando le più svariate funzioni. Ogni parete attrezzata è realizzata su misura a partire da singoli moduli, assemblati in modo da creare diversi disegni che si adattano allo spazio e alla zona giorno: strutture sospese, poggianti a terra, ad angolo. Le pareti attrezzate assolvono ad una combinazione di funzioni: contenitori di stoviglie e accessori per la casa, oggettistica, librerie, spazi multimediali. Esse vengono pensate e organizzate in base alle esigenze del cliente e progettate su misura utilizzando il frassino. Il legno di frassino ha la principale caratteristica di essere molto elastico e flessibile, tanto da renderlo il più robusto e resistente fra i legni prodotti in europa. Ogni nostra creazione è unica, composizioni studiate secondo criteri di estrema eleganza e personalizzazioni di altissimo pregio rendono ogni progetto un'opera d'arte, capace di supportare ogni esigenza di contenimento, esposizione, funzionalità.



LE PARETI

Altea

living room design
 contemporary

articolo **ALTEA**
 soggiorno componibile in FRASSINO.
 modular living room in ASH WOOD.
 cm. l. 315+15 p. 50



Our contemporary equipped walls are modular structures that furnish entire rooms, performing the most varied functions. Each equipped wall is made to measure starting from single modules, assembled to create different designs that adapt to the space and the living area: suspended structures, resting on the ground, at an angle. The equipped walls perform a combination of functions: containers of dishes and home accessories, objects, bookcases, multimedia spaces. They are conceived and organized according to the customer's needs and custom-made using the ash. Ash wood has the main characteristic of being very elastic and flexible, so as to make it the most robust and resistant among the woods produced in Europe. Each of our creations is unique, compositions studied according to criteria of extreme elegance and high-quality customizations make each project a work of art, capable of supporting any need for containment, display, functionality.

articolo **NOA**
soggiorno componibile in FRASSINO.
modular living room in ASH WOOD.
cm. I. 252 p. 50

Immaginiamo la parete di un soggiorno o di uno studio come un foglio bianco da riempire liberamente: un tratto di matita che si evolve, certe volte crea percorsi, certe altre prende direzioni inaspettate o cambia repentinamente stile e umore. Tutto questo si traduce nel linguaggio dell'artigiano in un arredo per la zona giorno composto da moduli bassi, colonne, pensili, ripiani, griglie e pannelli. La combinazione di questi elementi crea possibilità infinite di disegni, effetti cromatici e intrecci di linee, per una parete attrezzata realizzata su misura che si adatta perfettamente alle esigenze dello spazio e dei committenti.

We imagine the wall of a living room or study as a blank sheet to be filled freely: a pencil stroke that evolves, sometimes creates paths, sometimes other takes unexpected directions or suddenly changes style and mood. All this translates into the language of the craftsman in a furniture for the living area consisting of low modules, columns, wall units, shelves, grids and panels. The combination of these elements creates infinite possibilities of designs, chromatic effects and interweaving of lines, for a custom-made equipped wall that perfectly adapts to the needs of the space and the clients.

living room design
contemporary

Noa





traforo tetris. tetris perforated.

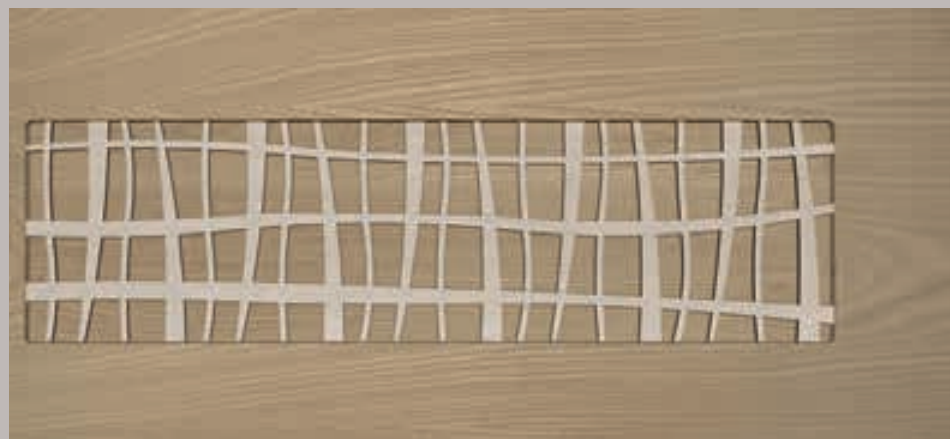

traforo natura. nature perforated.



traforo letter. letter perforated.

Produciamo trafori su ordinazione e possono essere personalizzati per materiali, dimensione, forma, disegno e colore e ben si adattano nelle più moderne case contemporanee.

We produce tunnels to order and can be customized for materials, size, shape, design and color and are well suited in the most modern contemporary homes.

articolo **GILDA**
soggiorno componibile in FRASSINO.
modular living room in ASH WOOD.
cm. l. 252 p. 50



← **Gilda**
living room design
contemporary

Tania



living room design
contemporary

articolo **TANIA**
soggiorno componibile ad angolo
in **FRASSINO**, modular corner living
room in **ASH WOOD**,
cm. lato SX 342 p. 55
lato DX 279 p. 55



LE PARETI



Crea il tuo soggiorno componibile classico o moderno, lineare o angolare su misura in armonia con l'arredamento che hai scelto per la tua casa. Le soluzioni per soggiorni moderni componibili che creiamo uniscono funzionalità ed estetica per creare ambienti capaci di soddisfare entrambe queste esigenze. Flessibilità, design e contemporaneità, solo tre fra i tanti aggettivi che è possibile attribuire ai mobili libreria e ai sistemi multimediali siamo riusciti a progettare librerie moderne a parete e centrostanza funzionali ed allo stesso tempo eleganti e raffinate.

Create your classic or modern modular living room, linear or angular made to measure in harmony with the furniture you have chosen for your home. The solutions for modern modular living rooms that we create combine functionality and aesthetics to create environments capable of satisfying both these needs. Flexibility, design and modernity, only three of the many adjectives that can be attributed to bookcase furniture and multimedia systems, we have managed to design modern wall bookcases and functional and self-centering space that are at the same time elegant and refined.

articolo **ANITA**
soggiorno componibile in FRASSINO
con inserti specchio. modular living room
in ASH WOOD with mirror inserts.
cm. l. 315+15 p. 55 h. 201



Anita

living room design
contemporary

Noemi

living room design
contemporary



articolo **NOEMI**
soggiorno componibile ad angolo
in **FRASSINO**, modular corner
living room in **ASH WOOD**.
cm. lato SX 279 p. 55
lato DX 342 p. 55



LE PARETI



Alice

living room design
contemporary

LE PARETI



articolo **ALICE**
soggiorno componibile in FRASSINO.
modular living room in ASH WOOD.
cm. l. 315 p. 55 h. variabile

pensili in FRASSINO profondità cm. 36,5 / 29,5 / 24,5.
hanging in ASH WOOD depth cm. 36.5 / 29.5 / 24.5.



articolo 2062
pensile orizzontale 2 ante vetro.
2 glass doors horizontal hanging.
cm. l. 126 p. 36,5 h. 63



articolo 2063
pensile orizzontale anta vetro vasistas.
vasistas glass door horizontal hanging.
cm. l. 126 p. 36,5 h. 40



articolo 2061
pensile verticale 2 ante vetro.
2 glass doors vertical hanging.
cm. l. 63 p. 36,5 h. 126



articolo 2064
pensile verticale anta vetro.
1 glass door vertical hanging.
cm. l. 40 p. 36,5 h. 126

sistema componibile modular system



articolo 2060
pensile 1 anta vetro.
1 glass door hanging.
cm. l. 63 p. 36,5 h. 63



articolo 2085
pensile 1 anta ribalta.
hanging flap door 1 door.
cm. l. 63 p. 36,5 h. 63



articolo 2086
pensile 1 anta ribalta.
hanging flap door 1 door.
cm. l. 63 p. 36,5 h. 63



articolo 2087
pensile 1 anta vasistas.
hanging vasistas 1 door.
cm. l. 63 p. 36,5 h. 63



articolo 2088
pensile 1 anta vasistas.
hanging vasistas 1 door.
cm. l. 63 p. 36,5 h. 63



articolo 2081
pensile anta ribalta e vani a giorno.
hanging with flap opening compart.
cm. l. 192 p. 36,5 h. 40



articolo 2077
pensile orizzontale ribalta.
horizontal hanging with flap.
cm. l. 126 p. 36,5 h. 40



articolo 2078
pensile orizzontale ribalta.
horizontal hanging with flap.
cm. l. 126 p. 36,5 h. 40



articolo 2079
pensile orizzontale vasistas.
horizontal hanging vasistas.
cm. l. 126 p. 36,5 h. 40



articolo 2080
pensile orizzontale vasistas.
horizontal hanging vasistas.
cm. l. 126 p. 36,5 h. 40



articolo 2089
pensile orizzontale a giorno.
horizontal hanging compartment.
cm. l. 126 p. 33,5 h. 40



articolo 2070
pensile con anta o ribalta.
hanging with door or flap door.
cm. l. 63 p. 36,5 h. 40



articolo 2093
pensile basso ad angolo con vano.
corner low hanging with compartment.
cm. l. 90 p. 90 h. 20



articolo 2094
pensile alto ad angolo a giorno.
corner high hanging with compartment.
cm. l. 90 p. 90 h. 40

basi in FRASSINO con zoccolo. bases in ASH WOOD with plinth.



articolo 2065
base bassa corta 1 cas. con maniglia.
short low base 1 drawers with handle.
cm. l. 63 p. 55 h. 25



articolo 2066
base alta corta 1 cestone con maniglia.
short high base 1 drawers with handle.
cm. l. 63 p. 55 h. 43,5



articolo 2067
base bassa lunga 1 cest. con maniglia.
long low base 1 drawers with handle.
cm. l. 126 p. 55 h. 25



articolo 2068
base alta lunga 1 cestone con maniglia.
long high base 1 drawers with handle.
cm. l. 126 p. 55 h. 43,5



articolo 2069/A
base alta 1 anta apertura PUSH PULL.
1 door high base PUSH PULL opening.
cm. l. 63 p. 36,5 h. 66,5



articolo 2069/B
base bassa 1 anta apertura PUSH PULL.
1 door low high base PUSH PULL opening.
cm. l. 63 p. 36,5 h. 43,5



articolo 2095
base bassa ad angolo con vano.
corner low base with compartment.
cm. l. 90 p. 90 h. 25



articolo 2096
base alta ad angolo a giorno.
corner high base with compartment.
cm. l. 90 p. 90 h. 43,5

basi sospese in FRASSINO. suspended bases in ASH WOOD.



articolo 2065/sosp.
base sospesa bassa corta 1 cassetto.
short low suspended base 1 drawers.
cm. l. 63 p. 36,5 h. 20



articolo 2066/sosp.
base sospesa alta corta 1 cestone.
short high suspended base 1 drawers.
cm. l. 63 p. 36,5 h. 43,5



articolo 2067/sosp.
base sospesa alta lunga 1 cestone.
long high suspended base 1 drawers.
cm. l. 126 p. 36,5 h. 20



articolo 2068/sosp.
base sospesa alta lunga 1 cestone.
long high suspended base 1 drawers.
cm. l. 126 p. 36,5 h. 43,5

colonne. columns.



articolo 2075
colonna 3 ante vetro.
3 glass door column.
cm. l. 63 p. 36,5 h. 192

mensole con segreto.
shelves with secret.



articolo 2076
mensola apribile con segreto.
openable shelf with secret.
cm. l. 189 p. 46 sp. 8

mensole. shelves.



articolo 2072
mensola cm. 63. shelf 63 cm.
cm. l. 63 p. 36,5 sp. 4



articolo 2073
mensola cm. 126. shelf 126 cm.
cm. l. 126 p. 36,5 sp. 4



articolo 2074
mensola cm. 189. shelf 189 cm.
cm. l. 189 p. 36,5 sp. 4



articolo 2092
maniglia legno con traforo.
wooden handle with fretwork.

i trafori (non compresi). the perforated (not included).

produciamo trafori su ordinazione e possono essere personalizzati per materiali, dimensione, forma, disegno e colore e ben si adattano nelle più moderne case contemporanee.
we produce tunnels to order and can be customized for materials, size, shape, design and color and are well suited in the most modern contemporary homes.



traforo tetris tetris perforated

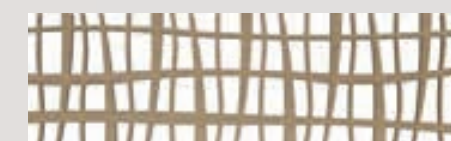

traforo natura nature perforated



traforo letter letter perforated

ante. doors.

tutti i moduli sono calcolati con anta vetro o liscia (vetro non incluso).
all modules are calculated with glass or smooth doors (glass not included).



articolo 2060/T
pannello traforato per base e pensili.
perforated panel for base and hanging.
cm. l. 63 h. 63



articolo 2068/T
pannello traforato per base e pensili.
perforated panel for base and hanging.
cm. l. 126 h. 34

living room design
contemporary



le Pareti

Italiancollectionslivingroom 96

Tanto gusto e tanta qualità, tutta italiana. Sul fronte del design, l'arredamento elegante è sempre stato uno degli obiettivi primari della produzione made in Italy, lo stile sobrio e moderno si integra perfettamente con la massima funzionalità e con la massima cura costruttiva, e questo per far sì che tutti i prodotti siano sempre adeguati a un'utenza esigente e attenta alle novità, alla raffinatezza e al comfort. Ogni casa specialmente negli spazi più rappresentativi, rispecchia atteggiamenti, abitudini, scelte ed esclusioni che nell'insieme delineano il carattere e disegnano i tratti salienti di chi vi abita. La casa vissuta cioè come vetrina o come conchiglia, come teatro dove allestire scenografie domestiche oppure, ancora come isola riservata e gelosamente custodita. Un'espressione di personalità comunque, che contribuisce a delineare con un sistema d'arredo flessibile e completo, ricco di particolari importanti e realizzato con la globale qualità che caratterizza ogni nostra proposta. Potrete individuare la composizione migliore per disegnare "su misura" il Vostro ambiente ideale. Tante soluzioni per una casa davvero personale, arredata partendo dalle esigenze di ognuno. E' questo il nostro grande pregio, un programma eclettico che unisce funzionalità e design in ogni zona della casa.

Lots of taste and lots of quality, all Italian. On the design front, elegant furnishings have always been one of the primary objectives of Made in Italy production, the sober and modern style integrates perfectly with maximum functionality and maximum construction care, and this is to ensure that all products are always suitable for demanding users who are attentive to innovation, refinement and comfort. Each house, especially in the most representative spaces, reflects attitudes, habits, choices and exclusions which together outline the character and draw the salient features of those who live there. That is, the house experienced as a showcase or as a shell, as a theater where domestic scenes can be set up or, even as a private and jealously guarded island. An expression of personality however, which helps to outline a flexible and complete furnishing system, full of important details and created with the global quality that characterizes each of our proposals. You will be able to identify the best composition to "tailor-made" your ideal environment. Many solutions for a truly personal home, furnished starting from everyone's needs. This is our great value, an eclectic program that combines functionality and design in every area of the house.

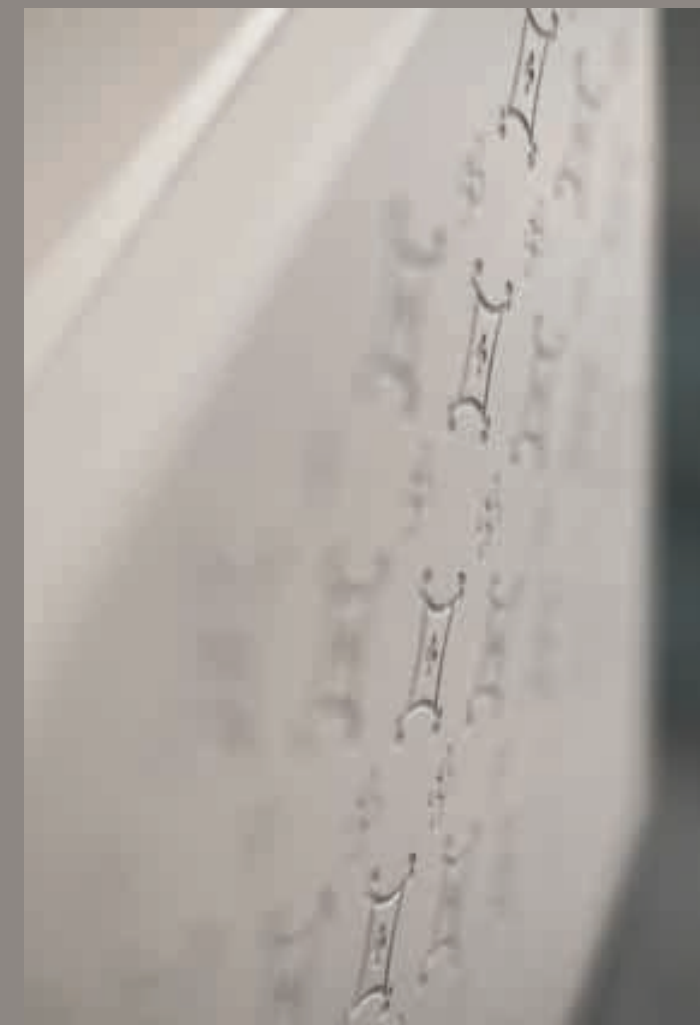

Tanto gusto e tanta qualità, tutta italiana. Sul fronte del design, l'arredamento elegante è sempre stato uno degli obiettivi primari della produzione made in Italy, lo stile sobrio e moderno si integra perfettamente con la massima funzionalità e con la massima cura costruttiva, e questo per far sì che tutti i prodotti siano sempre adeguati a un'utenza esigente e attenta alle novità, alla raffinatezza e al comfort. Ogni casa specialmente negli spazi più rappresentativi, rispecchia atteggiamenti, abitudini, scelte ed esclusioni che nell'insieme delineano il carattere e disegnano i tratti salienti di chi vi abita.

So much taste and so much quality, all Italian. On the design side, elegant furniture has always been one of the primary objectives of Made in Italy production, the sober and modern style integrates perfectly with the maximum functionality and with the utmost care, and this to ensure that all products they are always suitable for demanding users who are attentive to novelty, refinement and comfort. Every house, especially in the most representative spaces, reflects attitudes, habits, choices and exclusions that together delineate the character and draw the salient features of those who live there.

particolare piano decorato con vetro. detail decorated top with glass.



articolo **1091**
 tavolino rettangolare in TANGANIKA piano decorato e vetro appoggiato sopra.
 TANGANIKA rectangular coffee table top decorated and glass above.
 cm. l. 120 p. 70 h. 30

articolo **EMMA**
 soggiorno componibile in NOCE TANGANIKA.
 modular living room in TANGANIKA WALNUT.
 cm. vedi elementi singoli. see individual elements.

living room design
 contemporary

Emma →



articolo **ELENA**
soggiorno componibile in NOCE TANGANICA.
modular living room in TANGANICA WALNUT.
cm. l. 315+15 p. 55 h. 220

← **Elena**
living room design
contemporary

LE PARETI

sistema componibile modular system

→ **elementi singoli per composizioni. individual elements for composition.**

pensili in NOCE TANGANICA. hanging in TANGANICA WALNUT.



articolo 160
pensile 1 anta SX o DX.
1 door SX or DX hanging.
cm. l. 63 p. 36,5 h. 63



articolo 587
pensile a giorno.
compartment hanging.
cm. l. 63 p. 33,5 h. 63



articolo 159
pensile verticale 2 ante SX o DX.
2 doors SX or DX vertical hanging.
cm. l. 63 p. 36,5 h. 126



articolo 161
pensile a giorno.
compartment hanging.
cm. l. 34 p. 33,5 h. 126



articolo 164
pensile verticale 1 anta SX o DX.
1 door SX or DX vertical hanging.
cm. l. 34 p. 36,5 h. 126



articolo 158
pensile 1 anta smussato.
1 door blunted hanging.
cm. l. 63 p. 36,5 h. 63



articolo 162
pensile orizzontale 2 ante.
2 doors horizontal hanging.
cm. l. 126 p. 36,5 h. 63



articolo 163
pensile orizzontale 1 anta vasistas.
1 vasistas door horizontal hanging.
cm. l. 126 p. 36,5 h. 34



articolo 163/90
pensile orizzontale 1 anta vasistas.
1 vasistas door horizontal hanging.
cm. l. 90 p. 36,5 h. 34



articolo 584
pensile orizzontale a giorno.
compartment horizontal hanging.
cm. l. 126 p. 33,5 h. 29

basi in NOCE TANGANICA con zoccolo. bases in TANGANICA WALNUT with plinth.



articolo 169
base 1 anta.
1 door base.
cm. l. 63 p. 36,5 h. 68



articolo 165
base bassa 1 cassetto.
1 drawer low base.
cm. l. 63 p. 55 h. 25



articolo 166/vano
base alta 1 cassetto e vano.
1 drawer high base and compartment.
cm. l. 63 p. 55 h. 45



articolo 166
base alta 1 cestone.
1 big drawer high base.
cm. l. 63 p. 55 h. 45



articolo 167
base bassa lunga 1 cestone.
1 big drawer high long base.
cm. l. 126 p. 55 h. 25



articolo 168
base alta lunga 1 cestone.
1 big drawer high long base.
cm. l. 126 p. 55 h. 45



articolo 168/vano
base alta lunga 1 cestone e vano.
1 drawer high long base and comp.
cm. l. 126 p. 55 h. 45



articolo 170
base alta 1 cestone.
1 big drawer high base.
cm. l. 63 p. 36,5 h. 45



articolo 167/90
base bassa lunga 1 cestone.
1 big drawer high long base.
cm. l. 90 p. 55 h. 25



articolo 168/90
base alta lunga 1 cestone.
1 big drawer high long base.
cm. l. 90 p. 55 h. 45



articolo 168/90/vano
base alta lunga 1 cassetto e vano.
1 drawer high long base and comp.
cm. l. 90 p. 55 h. 45

colonne. columns.



articolo 175
colonna 3 ante Sx o DX.
3 doors SX or DX column.
cm. l. 63 p. 36,5 h. 192



articolo 171
colonna 4 ante Sx o DX.
4 doors SX or DX column.
cm. l. 63 p. 36,5 h. 166,5

ante comprese. including doors.

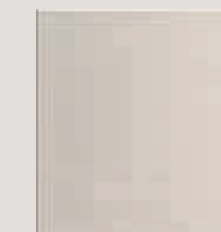

anta liscia. smooth door.



anta telaio. frame door.



anta smussata. blunted door.

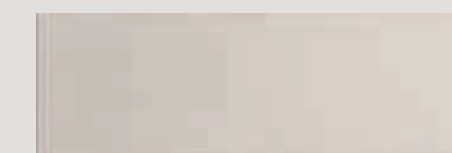

anta per ribalta. door with flap door.

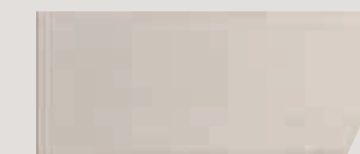

anta tagliata per ribalta. cut door for flap door.



anta tagliata per pensile quadrato. cut door for square hanging.



anta tagliata per base cm. 63. cut door for bases cm. 63.

ante in aggiunta. addition doors.

tutti i moduli sono calcolati con anta telaio in caso si volesse l'anta decoro bisogna aggiungere: all modules are calculated with frame door in case you want the decorative door we must add:

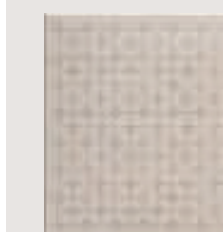

anta decoro per base o pensile. decorative door for base or hanging.

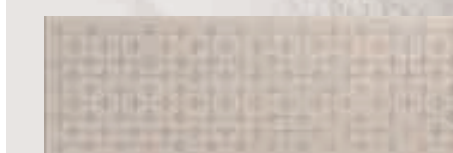

anta decoro per base o pensile. decorative door for base or hanging.

fianchi. sides.



articolo 576
fianco esterno. external side.
cm. p. 34 h. 226 sp. 4



articolo 577
fianco interno. internal side.
cm. p. 34 h. 226 sp. 4

schienali. backs.



articolo 573
schienale in TANGANICA l. 65.
TANGANICA backrest l. 65.
cm. p. 65 h. 226 sp. 1,8



articolo 574
schienale in TANGANICA l. 128.
TANGANICA backrest l. 128.
cm. p. 128 h. 226 sp. 1,8

mensole con segreto. shelves with secret.



articolo 776
mensola apribile con segreto.
openable shelf with secret.
cm. l. 189 p. 46 sp. 8

mensole. shelves.



articolo 072
mensola cm. 63. shelf 63 cm.
cm. l. 63 p. 33,5 sp. 4



articolo 073
mensola cm. 126. shelf 126 cm.
cm. l. 126 p. 33,5 sp. 4



articolo 074
mensola cm. 189. shelf 189 cm.
cm. l. 189 p. 33,5 sp. 4

mensola jolly. jolly shelf.



articolo 585
mensola con cavalletto. shelf with easel.
cm. l. 189 p. 33,5



articolo 586
mensola jolly. jolly shelf.
cm. l. 126 p. 33,5

living room design
contemporary



le Pareti

sfumature di colore shades of color

Arredare casa è un'avventura fantastica, che chiede tanta attenzione e lungimiranza per essere svolta al meglio. Fra le tante sfumature di questa avventura si inserisce come scegliere il colore dei mobili, un'opera che richiede una particolare attenzione in quanto dal suo risultato deriva lo stile finale dell'abitazione. La regola principale su come scegliere il colore si basa sulle proprie esigenze stilistiche, sui gusti personali e può anche sfociare in un accordo dedicato alla cromoterapia, la scienza che studia l'abbinamento fra i colori e le sensazioni che essi sanno suscitare sulle emozioni umane. L'idea che il colore sia una proprietà degli oggetti è molto diffusa, ma in realtà il colore è la sensazione che proviamo quando l'occhio è colpito dalla luce. Di cui, per semplicità, sono state individuate sei famiglie principali di colori che la compongono, anche se in realtà le sensazioni di colore sono potenzialmente infinite.

Furnishing your home is a fantastic adventure, which requires a lot of attention and foresight to be done at its best. Among the many nuances of this adventure, there is how to choose the color of the furniture, a work that requires particular attention as the final style of the home derives from its result. The main rule on how to choose color is based on one's stylistic needs, on personal tastes and can also lead to an agreement dedicated to chromotherapy, the science that studies the combination of colors and sensations that they can arouse on human emotions. The idea that color is a property of objects is widespread, but in reality color is the sensation we experience when the eye is hit by light. Of which, for simplicity, six main families of colors have been identified that make it up, even if in reality the color sensations are potentially infinite.

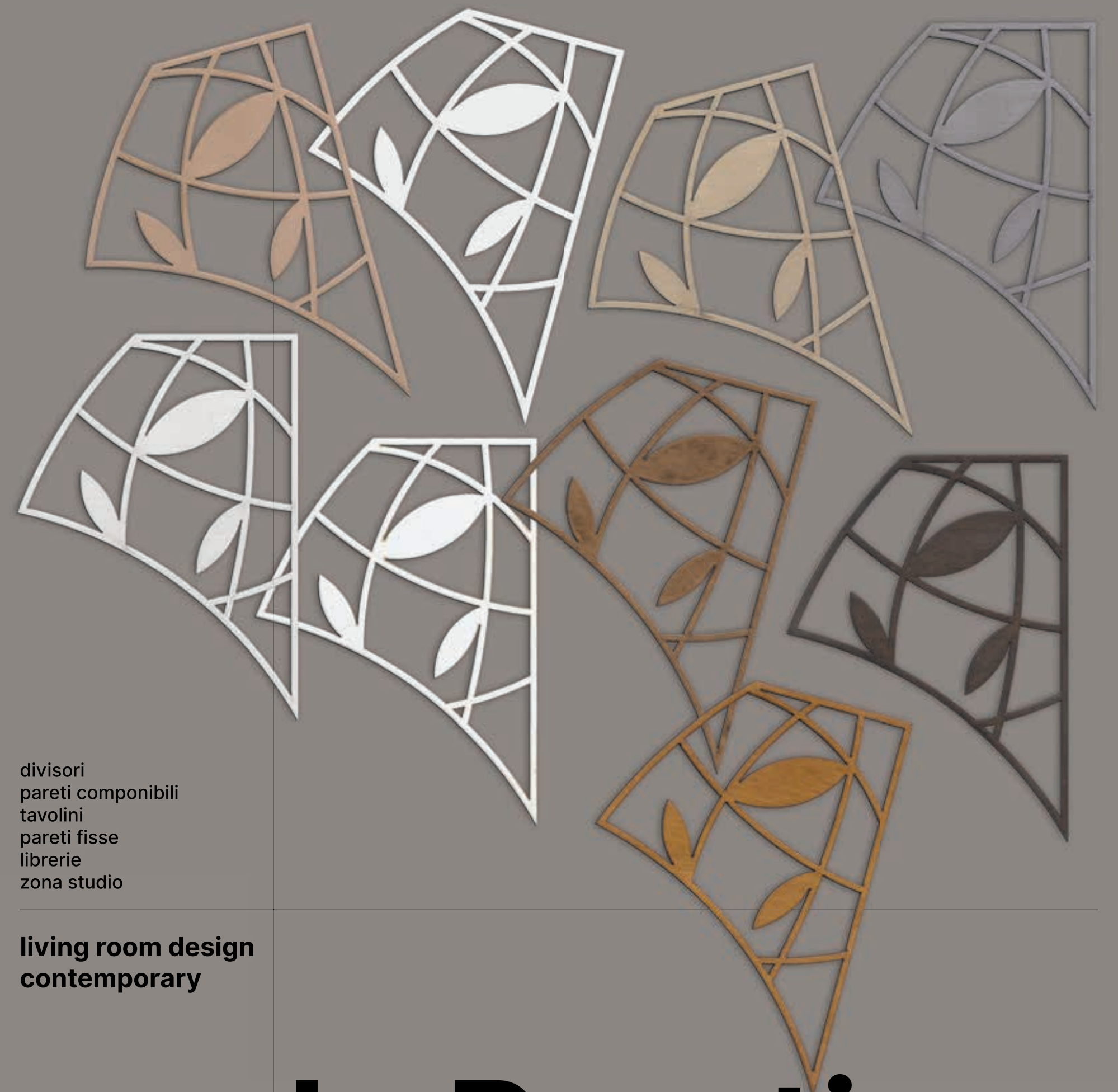

divisori
pareti componibili
tavolini
pareti fisse
librerie
zona studio

living room design
contemporary



le Pareti



I soggiorni moderni componibili forniscono una soluzione pratica alle tue esigenze perché sono studiati per rispondere in maniera puntuale allo stile di vita dei nostri giorni. Grazie alla loro struttura modulare, si adattano alla perfezione in ogni contesto: la loro versatilità consente di ottimizzare gli spazi migliorandone la vivibilità. Inoltre, questi soggiorni si caratterizzano per il design raffinato. Una collezione in frassino, dalle linee contemporanee, studiata per chi ama l'arredamento moderno e il design più raffinato. Arredare la zona giorno significa prediligere l'attenzione per le linee pulite e per la simmetria degli spazi. Per trovare la combinazione adatta a qualsiasi esigenza, proponiamo sistemi componibili su misura, per personalizzare gli spazi abitativi. Così come il concetto stesso di "design" prevede di unire le esigenze pratiche con quelle estetiche anche i mobili combinano funzionalità e bellezza per dare vita a creazioni uniche.

Modern modular living rooms provide a practical solution to your needs because they are designed to respond promptly to the lifestyle of today. Thanks to their modular structure, they adapt perfectly in any context: their versatility allows you to optimize spaces by improving their livability. In addition, these living rooms are characterized by refined design. A collection in ash, with contemporary lines, designed for those who love modern furniture and the most refined design. Furnishing the living area means preferring attention to clean lines and the symmetry of the spaces. To find the right combination for any need, we offer tailor-made modular systems to customize living spaces. Just as the concept of "design" itself plans to combine practical and aesthetic needs, furniture also combines functionality and beauty to create unique creations.

articolo **CECILIA**
soggiorno componibile in FRASSINO.
modular living room in ASH WOOD.
cm. l. 315+15 p. 37 h. 201



Cecilia

living room design
contemporary



FRASSINO finitura NATURA decoro BIANCO.
ASH WOOD NATURA finish with WHITE decor.

articolo **LETIZIA**
soggiorno componibile in FRASSINO.
modular living room in ASH WOOD.
cm. l. 315 p. 55 h. 201

living room design
contemporary

Letizia



LE PARETI



living room design
contemporary



le Pareti

Italiancollectionslivingroom 110

le essenze decor. →
the decor essences.

Tra le tendenze di oggi si osserva il ritorno dei colori caldi e degli elementi naturali come il legno. Infatti, quale materiale migliore del legno per creare atmosfere calde, naturali e accoglienti. Tanganica: impropriamente chiamato noce tanganica. Proviene dalla Costa D'avorio ed è un legno duro, pregiato e facile da lavorare. A differenza del noce, che tende al grigio, il tanganica è bruno con venature dritte e fitte di colore marrone tendente al rossiccio. Si utilizza per realizzare mobili di pregio e impiallaccature.

Among today's trends is the return of warm colors and natural elements such as wood. In fact, which best material of wood to create warm, natural and welcoming atmospheres. Tanganyan: improperly called Tanganyan walnut. It comes from Ivory Coast and is a hard, precious and easy to work wood. Unlike the walnut, which tends to gray, the tanganyica is brown with straight and thick veins of brownish color to the reddish. It is used to make precious furniture and veneers.



TANGANIKA finitura BIANCO PATINA decoro SABBIA



TANGANIKA finitura TORTORA decoro NOCE GRANO



TANGANIKA finitura NATURALE decoro BIANCO PATINA



TANGANIKA finitura GRIGIO decoro ANTRACITE



TANGANIKA finitura SABBIA



TANGANIKA finitura FANGO

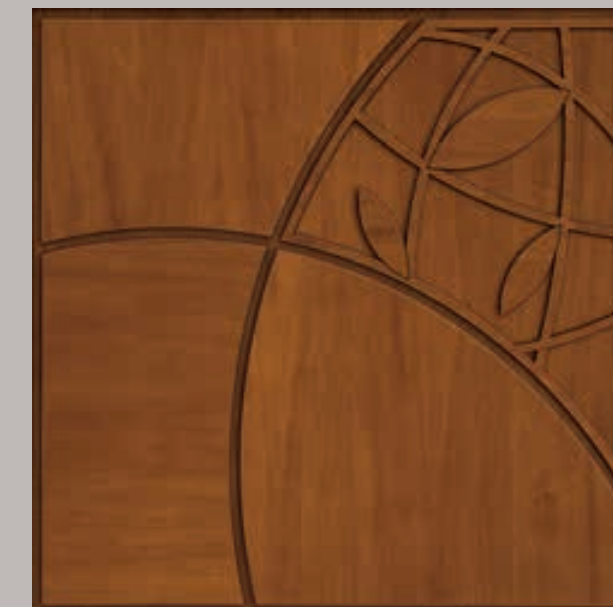

TANGANIKA finitura CILIEGIO PATINA



TANGANIKA finitura GRIGIO CHIARO

111 Italiancollectionslivingroom

articolo **ANDREA**
soggiorno componibile in NOCE TANGANICA.
modular living room in TANGANIKI WALNUT.
cm. l. 315+15 p. 55 h. 201

Andrea

living room design
contemporary



particolare mensola con segreto. detail shelf with secret.



articolo **797**
tavolo in FRASSINO piano ovale in cristallo.
table in ASH WOOD crystal oval top.
cm. l. 190 p. 95 h. 76

articolo **790**
tavolo in FRASSINO piano rettangolare in cristallo.
table in ASH WOOD rectangular crystal top.
cm. l. 180 p. 90 h. 76

living room design
contemporary

Erika

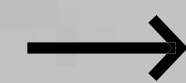

articolo **ERIKA**
soggiorno componibile in NOCE TANGANICA.
modular living room in TANGANICA WALNUT.
cm. l. 378 p. 55



Ilaria



living room design
contemporary

articolo **ILARIA**
soggiorno componibile in NOCE TANGANICA.
modular living room in TANGANICA WALNUT.
cm. l. 331 p. 37 h. 226

La Qualità delle nostre soluzioni è tutta italiana. Non solo per quanto riguarda lo stile, i materiali, la durata le finiture, ma anche per le possibilità di personalizzazione, la quantità di misure e varianti disponibili, che permette una grande flessibilità. Con i nostri soggiorni potrai creare infinite soluzioni per valorizzare la zona living, grazie a una proposta variegata di complementi modulari e componibili, contenitori pensili, basi, pareti a libreria. Soluzioni dal design contemporaneo, per risolvere ogni esigenza della tua zona living o creare un'atmosfera unica. Lasciati ispirare dalla nostra ampia palette di modelli e colori e scegli le finiture, sempre personalizzabili, per il soggiorno come più ti piace.

The quality of our solutions is entirely Italian. Not only in terms of style, materials, durability and finishes, but also for the possibility of customization, the quantity of sizes and variants available, which allows great flexibility. With our living rooms you can create infinite solutions to enhance the living area, thanks to a varied proposal of modular and modular accessories, hanging containers, bases, library walls. Contemporary design solutions, to solve every need in your living area or create a unique atmosphere. Let yourself be inspired by our wide palette of models and colors and choose the finishes, always customizable, for the living room as you like.



Gioele ↑

living room design contemporary

articolo **GIOELE**
 soggiorno componibile in NOCE TANGANIKA.
 modular living room in TANGANIKA WALNUT.
 cm. l. 242 p. 55

articolo **570**
 tavolino quadrato in NOCE TANGANIKA
 con piano in vetro. square coffee table
 in TANGANIKA WALNUT with glass top.
 cm. l. 90 p. 90 h. 30



articolo **PERLA**
 soggiorno componibile in NOCE TANGANIKA.
 modular living room in TANGANIKA WALNUT.
 cm. l. 242 p. 55

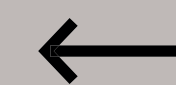

Perla

living room design contemporary

living room design
contemporary

articolo **GIOELE**
soggiorno componibile in NOCE TANGANIKA.
modular living room in TANGANIKA WALNUT.
cm. l. 335 p. 55 h. 201

Claudia →



articolo **FRANCESCA**
soggiorno componibile in NOCE TANGANIKA.
modular living room in TANGANIKA WALNUT.
cm. l. 315 p. 55 h. 226



↑ Francesca

living room design
contemporary

articolo **ROSA**
soggiorno componibile in NOCE TANGANICA.
modular living room in TANGANICA WALNUT.
cm. l. 315 p. 55

articolo **572**
boiserie porta TV in NOCE TANGANICA.
boiserie TV stand in TANGANICA WALNUT.
cm. l. 155 h. 106
vano TV. TV compartement.
cm. l. 135 h. 86

← **Rosa**
living room design
contemporary



Sofia →

living room design
contemporary

articolo **SOFIA**
soggiorno componibile in NOCE TANGANICA.
modular living room in TANGANICA WALNUT.
cm. l. 378 p. 55

living room design
contemporary

Greta →



articolo **GRETA**
soggiorno componibile in NOCE TANGANIK.
modular living room in TANGANIK.
cm. l. 300 p. 55 h. 224

articolo **ILENIA**
soggiorno componibile in NOCE TANGANIK.
modular living room in TANGANIK.
cm. l. 300 p. 55



← Ilenia

living room design
contemporary

**sistema componibile
modular system**



elementi singoli per composizioni. individual elements for composition.

**pensili in NOCE TANGANICA.
hanging in TANGANICA WALNUT.**



articolo **560**
pensile 1 anta vetro.
1 glass door hanging.
cm. l. 63 p. 36,5 h. 63

articolo **587**
pensile a giorno.
compartement hanging.
cm. l. 63 p. 33,5 h. 63



articolo **562**
pensile orizzontale 2 ante vetro.
2 glass doors horizontal hanging.
cm. l. 126 p. 36,5 h. 63

articolo **563**
pensile orizzontale anta vetro vasistas.
vasistas glass door horizontal hanging.
cm. l. 126 p. 36,5 h. 34



articolo **559**
pensile verticale 2 ante vetro.
2 glass doors vertical hanging.
cm. l. 63 p. 36,5 h. 126

articolo **561**
pensile verticale/orizzontale a giorno
vertical/horizontal hanging.
cm. l. 34 p. 33,5 h. 126



articolo **564**
pensile verticale anta vetro.
1 glass door vertical hanging.
cm. l. 34 p. 36,5 h. 126



articolo **563/90**
pensile orizzontale anta vetro vasistas.
vasistas glass door horizontal hanging.
cm. l. 90 p. 36,5 h. 34

articolo **584**
pensile orizzontale a giorno 3 vani.
3 compartement horizontal hanging.
cm. l. 126 p. 33,5 h. 29

basi in NOCE TANGANICA con zoccolo. bases in TANGANICA WALNUT with plinth.



articolo **569**
base 1 anta con decoro.
1 door with decor base.
cm. l. 63 p. 36,5 h. 68

articolo **565**
base bassa corta 1 cassetto.
short low base 1 drawers.
cm. l. 63 p. 55 h. 25



articolo **566**
base alta corta 1 cestone.
short high base 1 drawers.
cm. l. 63 p. 55 h. 45

articolo **566/vano**
base alta corta 1 cestone e vano.
short high base 1 drawers and comp.
cm. l. 63 p. 55 h. 45



articolo **567**
base bassa lunga 1 cestone.
long low base 1 drawers.
cm. l. 126 p. 55 h. 25



articolo **567/90**
base bassa lunga 1 cestone.
long low base 1 drawers.
cm. l. 90 p. 55 h. 25

articolo **568**
base alta lunga 1 cestone.
long high base 1 drawers.
cm. l. 126 p. 55 h. 45



articolo **568/vano**
base alta lunga 1 cestone e vano.
long high base 1 drawers and comp.
cm. l. 126 p. 55 h. 45

articolo **568/90**
base alta lunga 1 cestone.
long high base 1 drawers.
cm. l. 90 p. 55 h. 45



articolo **568/90/vano**
base alta lunga 1 cestone e vano.
long high base 1 drawers and comp.
cm. l. 90 p. 55 h. 45

**basi sospese in NOCE TANGANICA.
suspended bases in WALNUT TANGANICA.**



articolo **567/sosp.**
base sospesa bassa lunga 1 cestone.
long low suspended base 1 drawers.
cm. l. 126 p. 36,5 h. 20

articolo **567/90/sosp.**
base sospesa bassa lunga 1 cestone.
long low suspended base 1 drawers.
cm. l. 90 p. 36,5 h. 20



articolo **565/sosp.**
base sospesa bassa corta 1 cassetto.
short low suspended base 1 drawers.
cm. l. 63 p. 36,5 h. 20

articolo **566/sosp.**
base sospesa alta corta 1 cestone.
short high suspended base 1 drawers.
cm. l. 63 p. 36,5 h. 40



articolo **568/sosp.**
base sospesa alta lunga 1 cestone.
long high suspended base 1 drawers.
cm. l. 126 p. 36,5 h. 40

articolo **568/90/sosp.**
base sospesa alta lunga 1 cestone.
long high suspended base 1 drawers.
cm. l. 90 p. 36,5 h. 40

ante. doors.

tutti i moduli sono calcolati con anta vetro (vetro non incluso).

all modules are calculated with glass doors (glass not included).

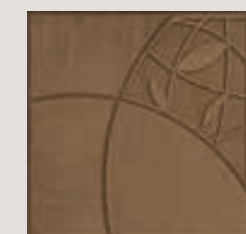

articolo **580**
anta chiusa per pensile.
closed door for hanging.
cm. l. 63 h. 63



articolo **581**
1/2 anta chiusa per pensile.
closed 1/2 door for hanging.
cm. l. 63 h. 43



articolo **583**
anta chiusa per pensile ribalta.
closed flap door for hanging.
cm. l. 126 h. 34

boiserie. boiserie.



articolo **572**
boiserie porta TV. TV stand boiserie.
vano TV cm. l. 135 x h. 86

colonne. columns.



articolo **575**
colonna 3 ante vetro.
3 glass door column.
cm. l. 63 p. 36,5

fianchi. sides.



articolo **576**
fianco esterno. external side.
cm. p. 34 h. 226 sp. 4



articolo **577**
fianco interno. inner side.
cm. p. 34 h. 226 sp. 4

schienali. backs.



articolo **573**
schienale. back.
cm. p. 65 h. 226 sp. 1,8



articolo **574**
schienale. back.
cm. p. 128 h. 226 sp. 1,8

**mensole con segreto.
shelves with secret.**



articolo **776**
mensola apribile con segreto.
openable shelf with secret.
cm. l. 189 p. 46 sp. 8

mensole. shelves.



articolo **72**
mensola. shelf. cm. l. 63 p. 33,5 sp. 4



articolo **73**
mensola. shelf. cm. l. 126 p. 33,5 sp. 4



articolo **74**
mensola. shelf. cm. l. 189 p. 33,5 sp. 4

mensola jolly. jolly shelf.



articolo **585**
mensola con cavalletto. shelf with tripod.
cm. l. 189 p. 33,5

**tavolino.
coffee table.**



articolo **570**
tavolino quadrato piano in vetro.
square coffee table glass top.
cm. l. 90 h. 30 p. 90

living room design
contemporary



le Pareti

Italiancollectionslivingroom 126

Tanto gusto e tanta qualità, tutta italiana. Sul fronte del design, l'arredamento elegante è sempre stato uno degli obiettivi primari della produzione made in Italy, lo stile sobrio e moderno si integra perfettamente con la massima funzionalità e con la massima cura costruttiva, e questo per far sì che tutti i prodotti siano sempre adeguati a un'utenza esigente e attenta alle novità, alla raffinatezza e al comfort. Ogni casa specialmente negli spazi più rappresentativi, rispecchia atteggiamenti, abitudini, scelte ed esclusioni che nell'insieme delineano il carattere e disegnano i tratti salienti di chi vi abita. La casa vissuta cioè come vetrina o come conchiglia, come teatro dove allestire scenografie domestiche oppure, ancora come isola riservata e gelosamente custodita. Un'espressione di personalità comunque, che contribuisce a delineare con un sistema d'arredo flessibile e completo, ricco di particolari importanti e realizzato con la globale qualità che caratterizza ogni nostra proposta. Potrete individuare la composizione migliore per disegnare "su misura" il Vostro ambiente ideale. Tante soluzioni per una casa davvero personale, arredata partendo dalle esigenze di ognuno. E' questo il nostro grande pregio, un programma eclettico che unisce funzionalità e design in ogni zona della casa.

Lots of taste and lots of quality, all Italian. On the design front, elegant furnishings have always been one of the primary objectives of Made in Italy production, the sober and modern style integrates perfectly with maximum functionality and maximum construction care, and this is to ensure that all products are always suitable for demanding users who are attentive to innovation, refinement and comfort. Each house, especially in the most representative spaces, reflects attitudes, habits, choices and exclusions which together outline the character and draw the salient features of those who live there. That is, the house experienced as a showcase or as a shell, as a theater where domestic scenes can be set up or, even as a private and jealously guarded island. An expression of personality however, which helps to outline a flexible and complete furnishing system, full of important details and created with the global quality that characterizes each of our proposals. You will be able to identify the best composition to "tailor-made" your ideal environment. Many solutions for a truly personal home, furnished starting from everyone's needs. This is our great value, an eclectic program that combines functionality and design in every area of the house.





← **Dubai**
living room design
contemporary



particolare mensola con segreto. detail shelf with secret.

articolo **DUBAI**
soggiorno componibile in NOCE
TANGANIKA con frontali in FRASSINO.
modular living room in TANGANIKA
WALNUT with ASH WOOD fronts.
cm. l. 305 p. 55 h. 201

articolo **CARLOTTA**
 soggiorno componibile in NOCE
 TANGANICA con frontali in FRASSINO.
 modular living room in TANGANICA
 WALNUT with ASH WOOD fronts.
 cm. l. 315 p. 55



Carlotta

living room design
 contemporary



LE PARETI

articolo **DORA**
 soggiorno componibile in NOCE
 TANGANICA con frontali in FRASSINO.
 modular living room in TANGANICA
 WALNUT with ASH WOOD fronts.
 cm. l. 252 p. 55

articolo **578**
 tavolino rettangolare in FRASSINO
 con piano in vetro. rectangular coffee
 table in ASH WOOD with glass top.
 cm. l. 120 p. 70 h. 30

Dora



living room design
 contemporary



living room design
contemporary

Melissa



articolo **MELISSA**
soggiorno componibile in NOCE
TANGANIKA con frontali in FRASSINO.
modular living room in TANGANIKA
WALNUT with ASH WOOD fronts.
cm. l. 378 p. 55 h. 224



LE PARETI

articolo **GAIA**
soggiorno componibile in NOCE
TANGANIKA con frontali in FRASSINO.
modular living room in TANGANIKA
WALNUT with ASH WOOD fronts.
cm. l. 315 p. 55



Gaia

living room design
contemporary

Soggiorni moderni in stile scandinavo, industriale, eclettico. Soggiorni componibili, economici ad angolo e con camino. Illuminazione ed accessori per soggiorni. Realizzare un soggiorno moderno è un'attività che non comporta stravolgimenti. Una delle stanze di casa maggiormente vissute, può essere polivalente, prevedendo un angolo studio, la zona relax o, se unita alla cucina, trasformarsi in un open space. L'idea di fondo è il ruolo della zona living: se è lo spazio della casa nella quale trascorrere molte ore, allora dovrà essere anche funzionale. Il soggiorno è il luogo adatto per incontri con parenti ed amici, dunque il requisito dell'essere confortevole è fondamentale.

Modern living rooms in Scandinavian, industrial, eclectic style. Modular living rooms, cheap corner and fireplace. Lighting and accessories for living rooms. Creating a modern living room is an activity that does not involve upheavals. One of the most experienced rooms in the house can be multipurpose, providing a study corner, a relaxation area or, if combined with the kitchen, transform into an open space. The basic idea is the role of the living area: if it is the space of the house in which to spend many hours, then it must also be functional. The living room is the suitable place for meetings with relatives and friends, therefore the requirement of being comfortable is fundamental.



LE PARETI

living room design
contemporary

le Pareti →



articolo **BUDAPEST**
soggiorno componibile in NOCE
TANGANIKA con frontali in FRASSINO.
modular living room in TANGANIKA
WALNUT with ASH WOOD fronts.
cm. l. 315 p. 55 h. 192



Budapest

living room design
contemporary



living room design
contemporary

Atlanta



articolo **ATLANTA**
soggiorno componibile in NOCE
TANGANIKÀ con frontali in FRASSINO.
modular living room in TANGANIKÀ
WALNUT with ASH WOOD fronts.
cm. l. 315 p. 55



**sistema componibile
modular system**



elementi singoli per composizioni. individual elements for composition.

pensili scocca in TANGANIKA e frontali FRASSINO.
hanging body in TANGANIKA and ASH WOOD fronts.



articolo **760**
pensile 1 anta vetro.
1 glass door hanging.
cm. l. 63 p. 36,5 h. 63



articolo **762**
pensile orizzontale 2 ante vetro.
2 glass doors horizontal hanging.
cm. l. 126 p. 36,5 h. 63



articolo **763**
pensile orizz. anta vetro vasistas.
1 vasistas glass door horiz. hanging.
cm. l. 126 p. 36,5 h. 34



articolo **764**
pensile verticale anta vetro.
1 glass door vertical hanging.
cm. l. 34 p. 36,5 h. 126



articolo **761**
pensile vetrinale 2 ante vetro.
2 glass doors vertical hanging.
cm. l. 63 p. 36,5 h. 126

basi scocca in TANGANIKA e frontali FRASSINO.
bases body in TANGANIKA and ASH WOOD fronts.



articolo **760/Z**
1 anta con zoccolo.
1 door with basement.
cm. l. 63 p. 36,5 h. 68



articolo **765**
bassa corta 1 cassetto con zoccolo.
1 drawer low short with basement.
cm. l. 63 p. 55 h. 25



articolo **766**
alta corta 1 cestone con zoccolo.
1 big drawer high short with basement.
cm. l. 63 p. 55 h. 45



articolo **767**
bassa lunga 1 cestone con zoccolo.
1 big drawer long low with basement.
cm. l. 126 p. 55 h. 25



articolo **768**
base alta lunga 1 cestone con zoccolo.
1 big drawer high long with basement.
cm. l. 126 p. 55 h. 45

pannelli decorati e lisci. panels decorated and smooth.



articolo **760/T**
pannello decorato
per pensile 760. decorated
panel for hanging 760.



articolo **760/L**
pannello liscio
per pensile 760. smooth
panel for hanging 760.



articolo **766/T**
pannello decorato
per pensile 766. decorated
panel for hanging 766.



articolo **768/T**
pannello decorato
per base 768. decorated
panel for base 768.



articolo **786**
pensile a giorno.
hanging compartment.
cm. l. 63 p. 33,5 h. 63



articolo **763/T**
pannello decorato
per pensile 763/764. decorated
panel for hanging 763/764.



articolo **763L**
pannello liscio
per pensile 763/764. smooth
panel for hanging 763/764.

mensole.
shelves.



articolo **772**
mensola corta. short shelf.
cm. l. 63 p. 33,5 sp. 4



articolo **773**
mensola media. media shelf.
cm. l. 126 p. 33,5 sp. 4



articolo **774**
mensola lunga. long shelf.
cm. l. 189 p. 33,5 sp. 4



articolo **776**
mensola con segreto. shelf with secret.
cm. l. 189 p. 46 sp. 8,5



articolo **584**
pensile orizzontale a giorno 3 vani.
3 compartement horizontal hanging.
cm. l. 126 p. 33,5 h. 29



articolo **585**
mensola jolly. jolly shelf.
cm. l. 189 p. 33,5



colonna.
column.

articolo **775**
colonna 3 ante. 3 doors column.
cm. l. 63 p. 36,5 h. 192

accessori. accesories.



living room design
contemporary

le Pareti

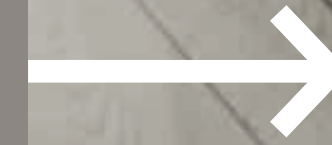

articolo **437**
specchiera rettangolare traforata.
rectangular perforated mirror.
cm. l. 92 h. 181

living room design
contemporary

Barcelona

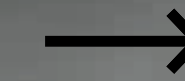

articolo **BARCELLONA**
soggiorno componibile in FRASSINO.
modular living room in ASH WOOD.
cm. l. 306 p. 50 h. 195

articolo **917**
madia 4 ante battenti in FRASSINO.
4 hinged doors cupboard in ASH WOOD.
cm. l. 120 p. 37 h. 120+17

LE PARETI



articolo **NIZZA**
 soggiorno componibile in FRASSINO.
 modular living room in ASH WOOD.
 cm. l. 252 p. 50

living room design
 contemporary

Nizza



living room design
 contemporary

Istanbul

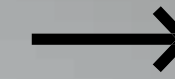

articolo **ISTANBUL**
 soggiorno componibile in FRASSINO.
 modular living room in ASH WOOD.
 cm. l. 311 p. 50



articolo **OSLO**
soggiorno componibile in FRASSINO.
modular living room in ASH WOOD.
cm. l. 306 p. 50

← **Oslo**
living room design
contemporary



LE PARETI



articolo **ATENE**
soggiorno componibile in FRASSINO.
modular living room in ASH WOOD.
cm. l. 306 p. 50 h. 195

Atene ↑
living room design
contemporary



articolo **DUBLINO**
soggiorno componibile in FRASSINO.
modular living room in ASH WOOD.
cm. l. 306 p. 50

living room design
contemporary

Dublino



articolo **930**
tavolino rettangolare
in FRASSINO con piano in vetro.
rectangular coffee table
in ASH WOOD with glass top.
cm. l. 120 p. 50 h. 32

← **Salisburgo**

living room design
contemporary

articolo **SALISBURGO**
soggiorno componibile in FRASSINO.
modular living room in ASH WOOD.
cm. l. 252 p. 50 h. 195



articolo **ZURIGO**
soggiorno componibile in FRASSINO.
modular living room in ASH WOOD.
cm. l. 318 p. 50 h. 195



living room design
contemporary

↑ **Zurigo**

**sistema componibile
modular system**



elementi singoli per composizioni. individual elements for composition.

pensili in FRASSINO. specificare tipo di anta.
hanging in ASH WOOD. specify type of door.



articolo **910***
pensile 1 anta vetro SX o DX.
1 glass door SX o DX hanging.
cm. l. 66 p. 37 h. 66



articolo **911**
pensile 2 ante vetro.
2 glass doors hanging.
cm. l. 120 p. 37 h. 66



articolo **912**
pensile 4 ante vetro.
4 glass doors hanging.
cm. l. 120 p. 37 h. 120



articolo **913**
pensile 1 anta vasistas.
1 vasistas glass door hanging.
cm. l. 120 p. 37 h. 45



articolo **909**
pensile verticale 1 anta vetro DX o SX.
1 glass door SX o DX vertical hanging.
cm. l. 45 p. 37 h. 120

basi in FRASSINO. bases in ASH WOOD.



articolo **918**
base 2 cestoni.
2 big drawers base.
cm. l. 120 p. 50 h. 40



articolo **919**
base 3 cestoni.
2 big drawers base.
cm. l. 186 p. 50 h. 40



articolo **920**
base 4 cestoni.
2 big drawers base.
cm. l. 245 p. 50 h. 40



articolo **914**
base 1 anta DX o SX.
1 door DX o SX base.
cm. l. 66 p. 37 h. 71



articolo **915**
base 2 ante DX o SX.
2 doors DX o SX base.
cm. l. 66 p. 37 h. 125



articolo **916**
base 4 ante. 4 doors base.
cm. l. 120 p. 37 h. 125



articolo **924**
colonna 2 ante DX o SX.
2 doors DX o SX column.
cm. l. 66 p. 37 h. 200

mensole. shelves.



articolo **921**
mensola corta. short shelf.
cm. l. 66 p. 37 sp. 3



articolo **922**
mensola media. medium shelf.
cm. l. 120 p. 37 sp. 3



articolo **923**
mensola lunga. long shelf.
cm. l. 186 p. 37 sp. 3

ante comprese.
including doors.



articolo **FV**
anta a telaio vetro.
glass frame door.



articolo **FR**
anta liscia con riquadri.
smooth door with squares.



articolo **FB**
anta con bassorilievo (solo da
laccare o con doratura/argentatura).
door with bas-relief (only to be
lacquered or gilded/silvered).



articolo **PL**
anta pannello liscio.
smooth panel door.



articolo **PD**
anta vetro con decoro.
glass door with decoration.

pannelli in aggiunta.
panels in addition.

articolo **926**
madia in FRASSINO 3 ante con
piedini in acciaio. cupboard in ASH
WOOD 3 doors with steel feet.
cm. l. 175 p. 45 h. 61+17

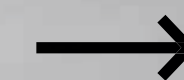

le Madie

cupboard design
contemporary



articolo **SINGAPORE**
soggiorno componibile in NOCE TANGANICA.
modular living room in TANGANICA WALNUT.
cm. l. 306 p. 36,5 h. 226

← **Singapore**
living room design
contemporary

living room design
contemporary

le Pareti →

articolo **MOSCA**
soggiorno componibile in NOCE TANGANICA.
modular living room in TANGANICA WALNUT.
cm. l. 306 p. 36,5/50 h. 226

← **Mosca**
living room design
contemporary



Azalea

living room design
contemporary



articolo **AZALEA**
soggiorno componibile in NOCE TANGANICA.
modular living room in TANGANICA WALNUT.
cm. l. 315 p. 55



LE PARETI



articolo **CAMELIA**
soggiorno componibile in NOCE TANGANICA.
modular living room in TANGANICA WALNUT.
cm. l. 252 p. 55

articolo **69**
tavolino rettangolare in NOCE
TANGANICA. rettangulat coffee table
in TANGANICA WALNUT.
cm. l. 126 p. 55 h. 25



living room design
contemporary

Camelia



Mimosa

living room design contemporary

articolo **MIMOSA**
 soggiorno componibile in NOCE TANGANIKA.
 modular living room in TANGANIKA WALNUT.
 cm. l. 315 p. 55



articolo **GINESTRA**
 soggiorno componibile in NOCETANGANIKA.
 modular living room in TANGANIKA WALNUT.
 cm. l. 252 p. 55

living room design contemporary

Ginestra



LE PARETI

IL SOGGIORNO COMPONIBILE MODERNO, UN CONNUBIO DI STILE E FUNZIONALITÀ. In principio c'erano la libreria e il mobile TV. Poi, col tempo, ci si è accorti che si poteva fonderli per realizzare soluzioni arredo molto più armoniche e funzionali: da un incontro di mobili e mensole, così nasce il soggiorno componibile moderno. Disponete sulle mensole anche qualche vaso moderno di gusto minimalistico, in ceramica o vetro soffiato, e l'insieme sarà veramente perfetto.

THE MODERN MODULAR LIVING ROOM , A STYLE CONNECTION AND FUNCTIONALITY. In the beginning there was the bookcase and the TV unit. Then, over time, we realized that we could merge them to create furniture solutions that are much more harmonious and functional: from a meeting of furniture and shelves, the modern modular living room is born. Arrange on the shelves also some modern minimalistic vase, in ceramic or blown glass, and the whole will be really perfect.





articolo **ORCHIDEA**
soggiorno componibile in NOCE TANGANIKA.
modular living room in TANGANIKA WALNUT.
cm. l. 378 p. 55



living room design
contemporary

Orchidea →

articolo **NINFEA**
soggiorno componibile in NOCE TANGANIKA.
modular living room in TANGANIKA WALNUT.
cm. l. 252 p. 55



Ninfea

living room design
contemporary



Primula



living room design contemporary

Grazie ad una sapiente combinazione di linee e materiali potrete ottenere un'elegante struttura che fungerà da libreria, mobile tv e supporto per lampade e soprammobili allo stesso tempo. Proprio questo è il punto di forza dei soggiorni componibili, la possibilità che vi offre di giocare con forme e volumi per dare vita a arredi unici.

Thanks to a skilful combination of lines and materials you can get an elegant structure that will act as a bookcase, TV cabinet and support for lamps and ornaments at the same time. This is precisely the strength of modular living, the possibility that offers you to play with shapes and volumes to give life to unique furnishings.



articolo **PRIMULA**
soggiorno componibile in NOCE TANGANIKA.
modular living room in TANGANIKA WALNUT.
cm. l. 252 p. 55



LE PARETI

articolo **70**
tavolino rettangolare alto con mensola.
rectangular coffee table with shelf.
cm. l. 126 p. 55 h. 45



articolo **MAGNOLIA**
soggiorno componibile in NOCE TANGANIKA.
modular living room in TANGANIKA WALNUT.
cm. l. 315 p. 55

living room design contemporary



Magnolia



le Pareti

progetto colore
color project

Il design e il colore? Una questione di valorizzazione dell'arredamento. Non è un caso, dunque, che il colore abbia trionfato in numerose fiere di design diventandone un grande protagonista. Negli ultimi venti anni abbiamo vissuto in una cultura "acromatica": nell'architettura ha dominato il bianco, nel design a farla da padrone è stato il grigio metallizzato, mentre nella moda il protagonista assoluto è stato il nero in risposta alla necessità di modelli estetici filiformi. Attualmente, invece, c'è una nuova voglia di colore, a patto, però, di non utilizzarlo in modo troppo spontaneo e non supportato da conoscenze specifiche ed adeguate. Spesso il colore viene ancora considerato come una semplice decorazione, mentre andrebbe utilizzato in un'ottica più ampia e in particolare come una combinazione tra arte e scienza in modo da rappresentare una nuova frontiera per i progettisti. Una delle ultime tendenze in fatto di stili è lo stile eclettico, in cui vengono mescolati gli stili classici con stili moderni, questo ha portato all'utilizzo di colori e stampe moderne applicate a mobili tradizionali. Allo stesso modo, è possibile vedere dei rivestimenti in stile classico utilizzati per un arredamento moderno, a testimonianza della ricerca di un equilibrio di espressione tra passato e presente. L'ambiente visivo quindi svolge un ruolo molto importante nell'espressione del mobile scelto per una determinata area. Lo sfondo sul quale scegliamo di collocare un arredo può fare spiccare i mobili positivamente, facendoli apparire più attraenti. Al contrario, uno sfondo inadeguato può competere con gli arredi e diventare lui stesso protagonista.

COLOR PROJECT Design and color? A question of enhancing the furnishings. It is no coincidence, therefore, that color has triumphed in numerous design fairs becoming a great protagonist. In the last twenty years we have lived in an "achromatic" culture: in architecture white has dominated, in design it has been metallic gray, while in fashion the absolute protagonist has been black in response to the need for aesthetic models filiform. Currently, however, there is a new desire for color, provided, however, not to use it too spontaneously and not supported by specific and adequate knowledge. Often the color is still considered as a simple decoration, while it should be used in a wider perspective and in particular as a combination between art and science in order to represent a new frontier for designers. One of the latest trends in styles is the eclectic style, in which classic styles are mixed with modern styles, this has led to the use of modern colors and prints applied to traditional furniture. In the same way, it is possible to see the classic style coatings used for a modern furnishing, reflecting the search for a balance of expression between past and present. The visual environment therefore plays a very important role in the expression of the furniture chosen for a given area. The background on which we choose to place a piece of furniture can make the furniture stand out positively, making them appear more attractive. On the contrary, an inadequate background can compete with the furnishings and become the protagonist himself.



anta traforo ARANCIO, perforated door.



anta traforo ROSSO, perforated door.



anta traforo VIOLA, perforated door.



anta traforo BORDÒ, perforated door.



living room design
contemporary

Girasole



articolo GIRASOLE
soggiorno componibile in NOCE TANGANICA,
modular living room in TANGANICA WALNUT,
cm. l. 189 p. 36,5 h. 192

Casablanca →

living room design
contemporary

articolo **CASABLANCA**
soggiorno componibile in NOCE TANGANIKA
frontali BRICOLA e TRIDIMENSIONALE.
modular living room in TANGANIKA WALNUT
BRICOLA and THREE-DIMENSIONAL.
cm. l. 252 p. 55



articolo **LIMA**
soggiorno componibile in NOCE TANGANIKA
frontali BRICOLA e TRIDIMENSIONALE.
modular living room in TANGANIKA WALNUT
BRICOLA and THREE-DIMENSIONAL.
cm. l. 252 p. 55

LE PARETI

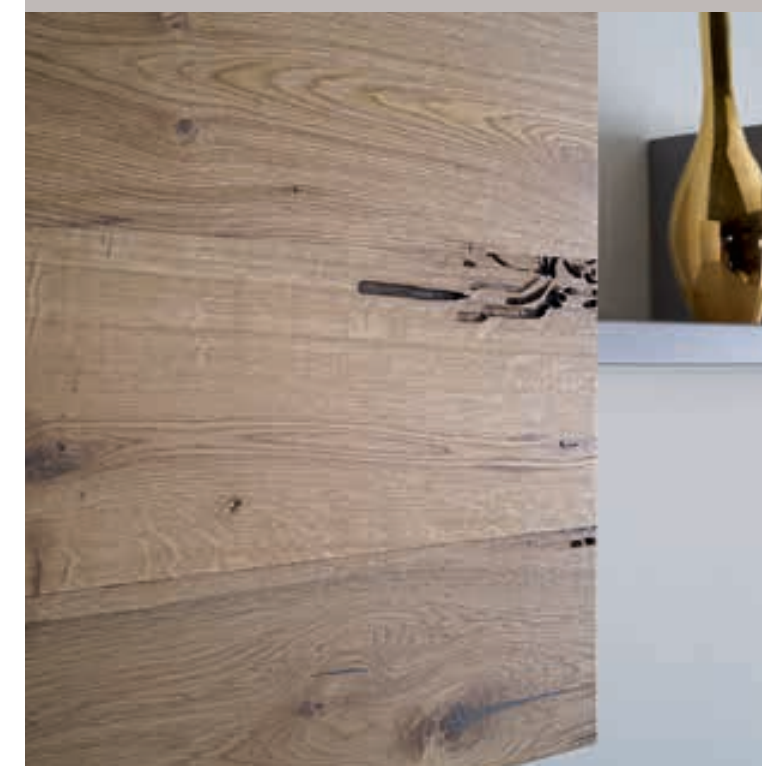

PIETRA 1 PIETRA 2 IMPRONTA
RILIEVO ARGENTO BRICOLA TRIDIMENSIONALE

LE COMPOSIZIONI SI POSSONO COMPORRE
CON ANTE E CASSETTI PERSONALIZZATE.
COMPOSITIONS CAN BE COMPOSED WITH
CUSHIONED DOORS AND DRAWERS.

living room design
contemporary

Lima ↑

sistema componibile modular system

→ **elementi singoli per composizioni.** individual elements for composition.

pensili in NOCE TANGANIKA.
hanging in TANGANIKA WALNUT.



articolo 60
pensile 1 anta vetro SX o DX.
1 glass door SX or DX hanging.
cm. l. 63 p. 36,5 h. 63



articolo 61
pensile a giorno.
compartement hanging.
cm. l. 63 p. 36,5 h. 63



articolo 62
pensile 2 ante vetro.
2 glass doors hanging.
cm. l. 126 p. 36,5 h. 63



articolo 63
pensile 1 anta vetro vasistas.
1 vasistas glass door hanging.
cm. l. 126 p. 36,5 h. 34



articolo 64
pensile verticale 1 anta vetro.
1 glass door vertical hanging.
cm. l. 34 p. 36,5 h. 126

basi in NOCE TANGANIKA con zoccolo.
bases in TANGANIKA WALNUT with plinth.



articolo 65
base bassa corta.
short low base.
cm. l. 63 p. 55 h. 25



articolo 67
base bassa lunga.
long low base.
cm. l. 126 p. 55 h. 25



articolo 66
base alta corta.
short high base.
cm. l. 63 p. 55 h. 45



articolo 68
base alta lunga.
long high base.
cm. l. 126 p. 55 h. 45

colonne.
columns.



articolo 71
colonna 1 anta.
1 door column.
cm. l. 63 p. 36,5 h. 192



articolo 75
colonna 3 ante.
3 doors column.
cm. l. 63 p. 36,5 h. 192

fianchi. sides.

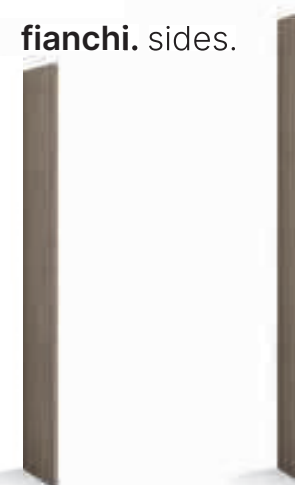

articolo 40
fianco esterno.
external side.
cm. p. 34 sp. 4 h. 226



articolo 41
fianco h. 252.
side h. 252.
cm. p. 34 sp. 4 h. 258

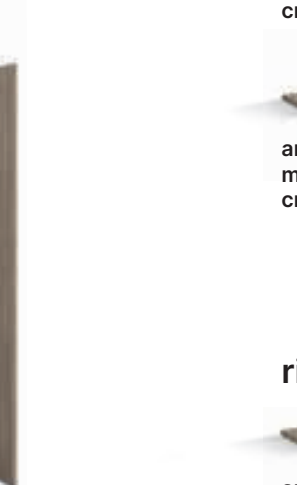

articolo 42
fianco interno.
inner side.
cm. p. 34 sp. 4 h. 226

mensole. shelves.



articolo 72
mensola corta. short shelf.
cm. l. 63 p. 33,7 sp. 4



articolo 73
mensola media. medium shelf.
cm. l. 126 p. 33,7 sp. 4



articolo 74
mensola lunga. long shelf.
cm. l. 189 p. 33,7 sp. 4

ripiani. shelves.



articolo 42
ripiano da l. 25. shelf from 25.
cm. l. 25 p. 34 sp. 4



articolo 43
ripiano da l. 40. shelf from 40.
cm. l. 40 p. 34 sp. 4



articolo 44
ripiano da l. 59,5. shelf from 59,5.
cm. l. 59,5 p. 34 sp. 4



articolo 45
ripiano da l. 128. shelf from 128.
cm. l. 128 p. 34 sp. 4

tavolini.
coffee tables.



articolo 69
tavolino rettangolare basso.
small rectangular coffee table.
cm. l. 126 p. 55 h. 25



articolo 70
tavolino alto con mensola.
coffee table with shelf.
cm. l. 126 p. 55 h. 45



articolo 46
schienale centrale porta TV.
central back for TV stand.
cm. l. 130 sp. 1,8 h. 99



articolo 47
cornice centrale porta TV.
central frame TV stand.
cm. l. 130 sp. 2,7 h. 99

Una linea di mobili dal design lineare e dalla personalità raffinata, dove agglomerati e legno si accostano in perfetta armonia. Le ante delle madie sono prive di maniglie e si aprono mediante sistema a spinta (push-pull) dotato di calamita per una perfetta chiusura. L'attenzione ai dettagli è massima, e proprio per questo non trascuriamo importanti particolari come i piedi, che sostengono l'intera struttura, realizzati in materiali inossidabili e tinteggiati con un'elegante finitura, si ergono con eleganza sottile dando l'idea a tutta la struttura di una sospensione immateriale.

A line of furniture with a linear design and refined personality, where agglomerates and wood are combined in perfect harmony. The doors of the sideboards have no handles and can be opened using a push-pull system equipped with a magnet for perfect closure. Attention to detail is maximum, and for this reason it does not neglect important details such as the feet, which support the entire structure, made of stainless materials and painted with an elegant finish, stand with subtle elegance giving the idea to the whole structure of an intangible suspension.

le ante. the doors.



articolo 52
anta push pull liscia.
push pull smooth door.
cm. l. 63 sp. 1,8 h. 63



articolo 53
anta telaio senza pannello.
frame door without panel.
cm. l. 63 sp. 1,8 h. 63



articolo 55
pannello traforato per art. 53.
perforated panel for art. 53.



articolo 56
pannello liscio per art. 53.
smooth panel for art. 53.





Italiancollectionslivingroom 170

divisori
pareti componibili
tavolini
pareti fisse
librerie
zona studio

living room design
classic furniture



le Pareti

171 Italiancollectionslivingroom



living room design
classic furniture



Luna

LE PARETI

articolo **LUNA**
composizione composta da:
composition composed of:

articolo **2150**
vetrina 1 porta apertura destra.
showcase 1 door right opening.
cm. l. 92 p. 54 h. 211+14

articolo **2151**
vetrina 1 porta apertura sinistra.
showcase 1 door left opening.
cm. l. 92 p. 54 h. 211+14

articolo **2151/c**
cimasa optional per vetrina.
optional crown for showcase.
cm. h. 14

articolo **2152**
base 3 porte con vano.
3 doors base with compartment.
cm. l. 172 p. 57,5 h. 69

articolo **2153**
pensile porta TV. hanging TV stand.
cm. l. 155 p. 30 h. 101+14
vano TV. TV compartement. 136 x 85

articolo **2153/c**
cimasa optional per porta TV.
optional crown for TV stand.
cm. h. 14

Sicilia

living room design
classic furniture



articolo **SICILIA**
soggiorno componibile in NOCE TANGANICA.
modular living room in TANGANICA WALNUT.
cm. l. 363 p. 47 h. 246
vano TV. TV compartement. cm. 121 x 145



LE PARETI

articolo **VULCANO**
soggiorno componibile in NOCE TANGANICA.
modular living room in TANGANICA WALNUT.
cm. l. 305 p. 47 h. 246
vano TV. TV compartement. cm. 156 x 116



(optional) particolare faretto nell' interno della vetrinetta. (optional) detailed spotlight inside the display cabinet.

living room design
classic furniture

Vulcano

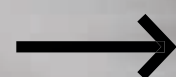



← **Stromboli**

articolo **STROMBOLI**
 soggiorno componibile in NOCE TANGANICA.
 modular living room in TANGANICA WALNUT.
 cm. l. 305 p. 47 h. 246 vano TV. TV compartement. cm. 156 x 116

**living room design
 classic furniture**

Ultimamente si sente molto parlare di arredamento in stile contemporaneo. Molti pensano erroneamente che dire contemporaneo e dire moderno sia la stessa cosa, che i due stili siano coincidenti. In realtà, lo stile contemporaneo è uno stile unico e particolare, che non va confuso con quello moderno. Lo stile contemporaneo è infatti uno stile che ricerca un'unione tra presente e passato, tra tradizione e innovazione. Esso è uno stile che cerca di venire incontro alle innovazioni tecnologiche, ai cambiamenti delle abitudini di vita, dei tempi e del modo di vivere in famiglia, tentando però di mantenere nella casa il calore e l'armonia tipiche delle abitazioni del passato. Proprio per questo motivo, ciò che caratterizza di più l'arredamento contemporaneo sono i colori chiari e luminosi, con una dominante presenza del bianco o del balck and white, le linee geometriche e pulite e l'utilizzo di materiali o pregiati, come ad esempio il legno massello, o moderni e innovativi, come il frassino. Infine, tipica di questo tipo di arredamento è la particolare attenzione a introdurre in modo armonico e coerente all'interno dell'ambiente le tecnologie di ultima generazione. Le parole d'ordine sono semplicità, comodità d'uso e attenzione all'estetica.

Lately we hear a lot about contemporary-style furniture. Many mistakenly think that saying contemporary and saying modern is the same thing, that the two styles are coincident. In reality, contemporary style is a unique and particular style, which should not be confused with the modern one. Contemporary style is in fact a style that seeks a union between present and past, between tradition and innovation. It is a style that seeks to meet technological innovations, changes in lifestyle, times and the way of life in the family, while trying to maintain the warmth and harmony typical of homes of the past in the home. Precisely for this reason, what characterizes contemporary furniture most are light and bright colors, with a dominant presence of white or balck and white, geometric and clean lines and the use of materials or fine materials, such as solid wood, or modern and innovative, such as ash. Finally, typical of this type of furniture is the particular attention to harmoniously and coherently introduce the latest generation technologies inside the environment. The keywords are simplicity, ease of use and attention to aesthetics.



LE PARETI

**living room design
 classic furniture**

↑ **Panarea**

articolo **PANAREA**
 soggiorno componibile in NOCE TANGANICA.
 modular living room in TANGANICA WALNUT.
 cm. l. 265 p. 47 h. 246
 vano TV. TV compartement. cm. 116 x 98

Pantelleria

living room design
classic furniture

articolo **PANTELLERIA**
soggiorno componibile in NOCE TANGANICA.
modular living room in TANGANICA WALNUT.
cm. l. 324 p. 47 h. 246
vano TV. TV compartement. cm. 116 x 146



living room design
classic furniture

Albarella

articolo **ALBARELLA**
soggiorno componibile in NOCE TANGANICA.
modular living room in TANGANICA WALNUT.
cm. l. 305 p. 47 h. 246
vano TV. TV compartement. cm. 156 x 106



living room design
classic furniture

Maddalena

Italiancollectionslivingroom 184



articolo **MADDALENA**
soggiorno componibile in NOCE TANGANICA.
modular living room in TANGANICA WALNUT.
cm. l. 208 p. 47 h. 246

Sardegna



living room design
classic furniture



articolo **SARDEGNA**
armadietto componibile in NOCE TANGANICA.
modular wardrobe in TANGANICA WALNUT.
cm. l. 144 p. 47 h. 246

185 Italiancollectionslivingroom

living room design
classic furniture

Torcello

articolo **TORCELLO**
soggiorno componibile in NOCE TANGANICA.
modular living room in TANGANICA WALNUT.
cm. l. 324 p. 47 h. 246

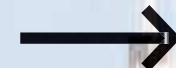

LE PARETI



articolo **LAMPEDUSA**
studio componibile in NOCE TANGANICA.
modular study room in TANGANICA WALNUT.
cm. l. 264,5 p. 47 h. 246

articolo **4050**
scrivania 6 cassetti. 6 drawers writing desk.
cm. l. 160 p. 70 h. 80

← **Lampedusa**
study room design
classic furniture

study room design
classic furniture

Lampedusa



articolo **LAMPEDUSA**
studio componibile in NOCE TANGANICA.
modular study room in TANGANICA WALNUT.
cm. l. 286 p. 47 h. 246

articolo **4050**
scrivania 6 cassetti. 6 drawers writing desk.
cm. l. 160 p. 70 h. 80



**sistema componibile
classic furniture**



elementi singoli per composizioni. individual elements for composition.

composizione colonne in NOCE TANGANICA. column composition in TANGANICA WALNUT.



articolo **4000/SX**
colonna componibile DX o SX.
modular system column DX or SX.
cm. l. 68 p. 40 h. 225

articolo **4001/SX**
colonna componibile DX o SX.
modular system column DX or SX.
cm. l. 68 p. 40 h. 225

articolo **4002/SX**
colonna componibile DX o SX.
modular system column DX or SX.
cm. l. 68 p. 40 h. 225

articolo **4003/SX**
colonna componibile DX o SX.
modular system column DX or SX.
cm. l. 68 p. 40 h. 225

articolo **4004/SX**
colonna componibile DX o SX.
modular system column DX or SX.
cm. l. 68 p. 40 h. 225

elementi in NOCE TANGANICA. TANGANICA WALNUT elements.



articolo **4005/SX**
colonna componibile DX o SX.
modular system column DX or SX.
cm. l. 68 p. 40 h. 225

articolo **4018**
scaffale con ripiani a giorno.
shelf with compartments.
cm. l. 40 p. 38 h. 225

articolo **4019**
scaffale con ripiani a giorno.
shelf with compartments.
cm. l. 40 p. 38 h. 140

articolo **4026**
schienale piccolo.
small backrest.
cm. l. 58 sp. 0,8 h. 225

articolo **4027**
schienale medio.
medium backrest.
cm. l. 138 sp. 0,8 h. 225

articolo **4028**
schienale grande.
large backrest.
cm. l. 156 sp. 0,8 h. 225



articolo **4006/SX**
colonna componibile DX o SX.
modular system column DX or SX.
cm. l. 138 p. 40 h. 225

articolo **4007/SX**
colonna componibile DX o SX.
modular system column DX or SX.
cm. l. 138 p. 40 h. 225

articolo **4008/SX**
colonna componibile DX o SX.
modular system column DX or SX.
cm. l. 138 p. 40 h. 225

articolo **4009/SX**
colonna componibile DX o SX.
modular system column DX or SX.
cm. l. 138 p. 40 h. 225

articolo **4010/SX**
colonna componibile DX o SX.
modular system column DX or SX.
cm. l. 138 p. 40 h. 225



articolo **4011/SX**
colonna componibile DX o SX.
modular system column DX or SX.
cm. l. 138 p. 40 h. 225



articolo **4020**
base 2 cestoni guide ammortizzate
e vano. base 2 drawers soft closing
guides. cm. l. 156 p. 40 h. 42



articolo **4021**
base 4 cassetti guide legno.
base 4 drawers wooden guides.
cm. l. 138 p. 40 h. 42



articolo **4022**
base cestone guide ammortizzate.
basket base soft closing guides.
cm. l. 58 p. 38 h. 37



articolo **4023**
base cassetto guide legno.
drawer base wooden guides.
cm. l. 58 p. 38 h. 11,8



articolo **4029**
anta piccola destra o sinistra.
small right or left door.
h. fino 70 cm.



articolo **4030**
pannello per anta piccola.
panel for small door.

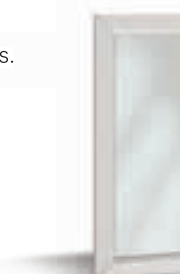

articolo **4031**
anta grande destra o sinistra.
large right or left door.
h. oltre 70 cm.



articolo **4032**
pannello per anta grande.
panel for large door.



articolo **4012**
cappello al metro lineare.
hat by the metre.

articolo **4013**
zoccolo al metro lineare.
basement hat by the metre.

articolo **4014**
mensola piccola cm. 58.
small shelf cm. 58.
cm. l. 58 p. 38 sp. 2,5



articolo **4015**
mensola media cm. 116.
medium shelf cm. 58.
cm. l. 116 p. 38 sp. 2,5



articolo **4016**
mensola grande cm. 156.
large shelf cm. 156.
cm. l. 156 p. 38 sp. 2,5



articolo **4017**
pensile 2 vasistas vetro e vano.
2 vasistas glass door hanging and
compartement. cm. l. 156 p. 40 h. 42



articolo **4024**
base cestone guide ammortizzate.
basket base soft closing guides.
cm. l. 116 p. 38 h. 37



articolo **4025**
base cassetto guide legno.
drawer base wooden guides.
cm. l. 116 p. 38 h. 11,8



articolo **4033**
decoro in legno per anta.
wooden decoration for door.



articolo **4034**
faretto al led per interno.
indoor LED spotlight.

LE PARETI

articolo **1013**
 soggiorno in NOCE TANGANIKA porte e cestoni
 con intarsio. living room in TANGANIKA WALNUT
 doors and big drawers with inlay.
 cm. l. 267 p. 48/56 h. 236
 vano TV. TV compartement. 130 x 98



living room design
 classic furniture

Charlotte

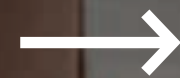

Italiancollectionslivingroom 194

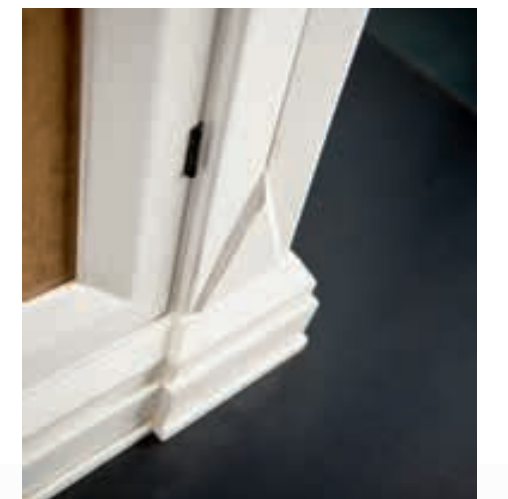

LE PARETI

articolo **1014**
 soggiorno in NOCE TANGANIKA porte
 e cestoni con intarsio. living room in TANGANIKA
 WALNUT doors and big drawers with inlay.
 cm. l. 312 p. 48/56 h. 236
 vano TV. TV compartement.
 cm. 130 x 98



195 Italiancollectionslivingroom



LE PARETI

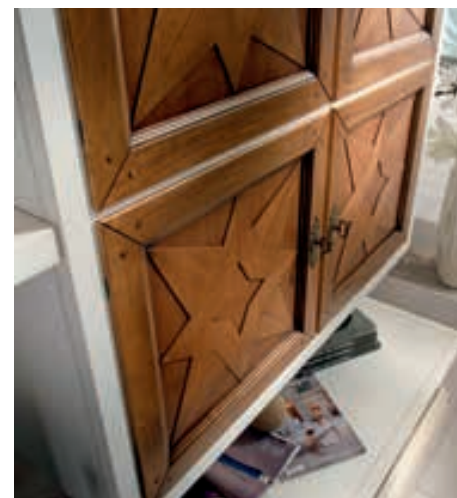

articolo **POLLINI**
 soggiorno in NOCE TANGANICA.
 living room in TANGANICA WALNUT.
 cm. l. 298 p. 56
 vano TV. TV compartement. l. 126

Pollini ↑

living room design
 classic furniture



articolo **810**
 soggiorno in NOCE TANGANICA con intarsio.
 living room in TANGANICA WALNUT with inlay.
 cm. l. 285 p. 57 h. 242
 vano TV. TV compartement. 130 x 86

articolo **810/l**
 soggiorno in NOCE TANGANICA con intarsio
 ante centrali chiuse. living room in TANGANICA
 WALNUT with inlay central closed doors.
 cm. l. 285 p. 57 h. 242
 vano TV. TV compartement. 130 x 86



living room design
classic furniture

Verdi →

Italiancollectionslivingroom 198

articolo **VERDI**
soggiorno in NOCE TANGANIKA ante con rilievo.
living room in TANGANIKA WALNUT doors with relief.
cm. l. 328 p. 57 h. 245 vano TV. TV compartement. 124 x 119
n.b.: su richiesta ante centrali chiuse con rilievo.
n.b.: on request central doors closed with relief.

→
Vivaldi

living room design
classic furniture



articolo **VIVALDI**
soggiorno in NOCE TANGANIKA ante con rilievo.
living room in TANGANIKA WALNUT doors with relief.
cm. l. 281 p. 57 h. 245 vano TV. TV compartement. 124 x 119
n.b.: su richiesta ante centrali chiuse con rilievo.
n.b.: on request central doors closed with relief.



199 Italiancollectionslivingroom



Puccini
living room design
classic furniture



articolo **SALIERI**
soggiorno in NOCE TANGANICA
ante con rilievo. living room in TANGANICA
WALNUT doors with relief.
cm. l. 281 p. 56,5 h. 248
vano TV. TV compartment. 124 x 62

living room design
classic furniture

Salieri ↑

articolo **PUCINI**
soggiorno in NOCE TANGANICA
ante con rilievo. living room in TANGANICA
WALNUT doors with relief.
cm. l. 326 p. 56,5 h. 248
vano TV. TV compartment. 124 x 62



articolo **672**
 soggiorno in NOCE TANGANIKA ante
 scorrevoli con decoro. living room
 in TANGANIKA WALNUT sliding doors
 with decor. cm. l. 277 p. 63 h. 242
 vano TV. TV compartement. 119 x 87
 mensola porta video.
 video shelf. h. 16 cm.

le Pareti living room design
 classic furniture





anta traforo. perforated door.



anta bugnata liscia. beveled smooth door.

ante disponibili
available doors



LE PARETI



articolo **672/L**
soggiorno in NOCE TANGANICA ante scorrevoli
bugnate lisce. living room in TANGANICA
WALNUT beveled smooth sliding doors.
cm. l. 277 p. 63 h. 242
vano TV. TV compartment. 119 x 87
mensola porta video. video shelf. h. 16 cm.

living room design
classic furniture

le Pareti





articolo **013/B**
 soggiorno in NOCE TANGANIKA bugnato
 ante centrali chiuse. ashlar living room
 in TANGANIKA WALNUT closed central doors.
 cm. l. 290 p. 59 h. 249
 vano TV. TV compartment. 124 x 81



Per il soggiorno scegli tra le pareti attrezzate classiche avorio quella che è più funzionale alle tue esigenze. Noi, comunque, suggeriamo di collocare i pensili nella parte inferiore delle pareti attrezzate classiche avorio perché il centro deve essere pensato per il mobile TV. Gli spazi laterali, invece, devono essere pensati per mini librerie ed eventuali credenze. Nel caso avessi deciso di occupare un'intera parete del soggiorno, perché vuoi sfruttare tutti gli spazi a disposizione evitando così di opprimere l'intero ambiente, puoi anche farti aggiungere delle mensole.

For the living room, choose the one that is more functional for your needs from the classic ivory wall units. We, however, suggest placing the wall units in the lower part of the classic ivory equipped walls because the center must be designed for the TV cabinet. The side spaces, on the other hand, must be designed for mini bookcases and any sideboards. In case you decided to occupy an entire wall of the living room, because you want to take advantage of all the available space, thus avoiding oppressing the entire environment, you can also have shelves added to it.

articolo **013**
 soggiorno in NOCE TANGANIKA bugnato.
 ashlar living room in TANGANIKA WALNUT.
 cm. l. 290 p. 59 h. 249
 vano TV. TV compartment. 124 x 81



LE PARETI

le Pareti
 living room design
 classic furniture

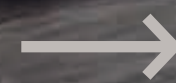



articolo **CRISTINA**
 soggiorno in NOCE TANGANIKAWALNUT inlay door.
 living room in TANGANIKAWALNUT inlay door.
 cm. l. 300 p. 56 h. 234
 vano TV. TV compartement. 153 x 93

living room design
 classic furniture
Cristina



articolo **CRISTINA**
 soggiorno in NOCE TANGANIKAWALNUT smooth door.
 living room in TANGANIKAWALNUT smooth door.
 cm. l. 300 p. 56 h. 234
 vano TV. TV compartement. 153 x 93

Arredamento sala da pranzo: lo spazio della convivialità. Quando invitiamo parenti ed amici per una cena, facciamo di tutto per ospitarli al meglio, organizzando gli spazi affinché si possano rilassare e godere piacevolmente la serata. Tuttavia, ci piacerebbe che i nostri ospiti rimanessero sorpresi e affascinati dall'arredamento e dallo stile della nostra casa. Molti erroneamente sono portati a considerare "design" sinonimo di oggetti o completamenti che curano esclusivamente l'aspetto esteriore delle cose, lasciando in secondo piano la comodità o l'usabilità. In realtà non è così e presentiamo oggi una selezione di zone da pranzo di vario stile in cui funzionalità e design si fondono in modo armonioso e a cui potrete ispirarvi per creare ambienti d'effetto che lasceranno i vostri ospiti a bocca aperta. La tipica sala da pranzo intesa come locale a sé stante, adibito esclusivamente alla convivialità, può sembrare ormai retaggio di un modo di abitare piuttosto lontano rispetto alle attuali consuetudini. In epoca contemporanea, convenzioni sociali più informali o ritmi lavorativi frenetici che portano spesso a pranzare fuori casa e, soprattutto, metrature degli alloggi sempre più ridotte, fanno sì che raramente si possa disporre di un locale apposito per il pranzo. Ciò non toglie che, avendo lo spazio sufficiente, una sala pranzo separata dalla cucina, può essere utile per vivere al meglio le occasioni conviviali con amici e parenti o gli eventi più formali, come pranzi e cene di lavoro.

Dining room furniture: the space of conviviality. When we invite relatives and friends for a dinner, we do everything to accommodate them to the fullest, organizing the spaces so that they can relax and enjoy the evening pleasantly. However, we would like our guests to be surprised and fascinated by the decor and style of our home. Many are mistakenly led to consider "design" synonymous with objects or completions that exclusively take care of the external appearance of things, leaving comfort or usability in the background. In reality this is not the case and today we present a selection of dining areas of various styles in which functionality and design blend harmoniously and which you can inspire to create striking environments that will leave your guests speechless. The typical dining room intended as a separate room, used exclusively for conviviality, may now seem to be a legacy of a way of living rather far from current customs. In contemporary times, more informal social conventions or frenetic work rhythms that often lead to lunch outside the home and, above all, increasingly smaller sizes of accommodation, mean that it is rarely possible to have a special room for lunch. This does not mean that, having sufficient space, a dining room separate from the kitchen can be useful to better enjoy convivial occasions with friends and relatives or more formal events, such as business lunches and dinners.

dining rooms design
contemporary



il Giorno



credenze
vetrine
argenterie
cristalliere
tavoli e sedie

dining rooms design
contemporary



il Giorno

articolo **591**
credenza 3 ante con decoro
2 cassetti interni, sideboard 3 doors
with decor 2 internal drawers,
cm. l. 200 p. 57 h. 93

articolo **590**
argenteria 2 ante con decoro,
silvercase 2 doors with decor,
cm. l. 155 p. 45 h. 193

articolo **593**
tavolo rettangolare allungabile,
extendable rectangular table,
cm. l. 160 p. 90 h. 80
aperto, open, 240 x 90

articolo **784**
sedia, chair,
cm. l. 48 p. 58 h. 99

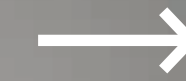

Marylin

dining room design
contemporary

IL GIORNO

articolo **781**
credenza 3 ante con decoro
2 cassetti interni, sideboard 3 doors
with decor 2 internal drawers.
cm. l. 200 p. 57 h. 105

articolo **782**
specchiera rettangolare traforata.
perforated rectangular mirror.
cm. l. 174 sp. 1,3 h. 80

articolo **783**
tavolo rettangolare allungabile.
extendable rectangular table.
cm. l. 160 p. 90 h. 80
aperto, open. 240 x 90

articolo **784**
sedia, chair.
cm. l. 48 p. 58 h. 99

articolo **780**
argenteria 2 ante con decoro.
silvercase 2 doors with decor.
cm. l. 155 p. 45 h. 205



IL GIORNO

dining room design
contemporary

←
Eva

articolo **786**
credenza 3 ante con decoro 2 cassetti
interni e zoccolo. sideboard 3 doors with decor
2 internal drawers and baseboard.
cm. l. 200 p. 57 h. 95

articolo **782**
specchiera rettangolare traforata.
perforated rectangular mirror.
cm. l. 174 sp. 1,3 h. 80

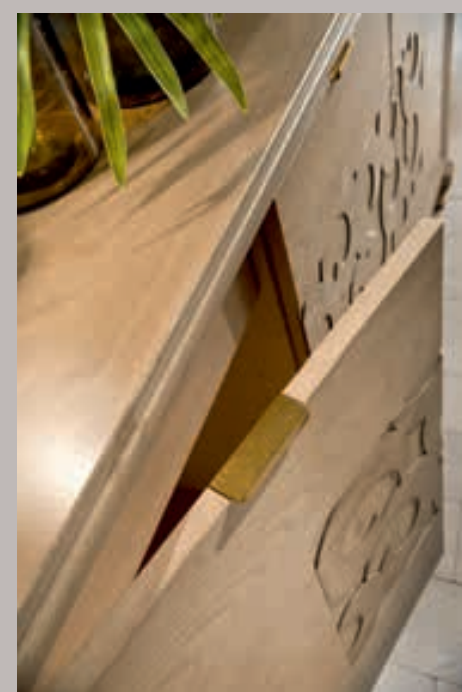

Eva zoccolo
dining room design
contemporary

articolo **785**
argenteria 2 ante con intaglio
e zoccolo. 2 carving doors
display cabinet baseboard.
cm. l. 155 p. 45 h. 193

articolo **781**
credenza 3 ante con decoro
2 cassetti interni. sideboard 3 doors
with decor 2 internal drawers.
cm. l. 200 p. 57 h. 105

articolo **782**
specchiera rettangolare traforata.
perforated rectangular mirror.
cm. l. 174 sp. 1,3 h. 80

articolo **783**
tavolo rettangolare allungabile.
extendable rectangular table.
cm. l. 160 p. 90 h. 80
aperto. open. 240 x 90

articolo **784**
sedia. chair.
cm. l. 48 p. 58 h. 99

articolo **780**
argenteria 2 ante con decoro.
silvercase 2 doors with decor.
cm. l. 155 p. 45 h. 205

dining room design
contemporary



Evabicolore



IL GIORNO



credenze
vetrine
argenterie
cristalliere
tavoli e sedie



dining rooms design
classic furniture



il Giorno

Iris

dining room design
classic furniture



articolo **2160**
credenza 2 ante 4 cassetti con guide ammortizzate.
2 doors sideboard 4 drawers with soft closing.
cm. l. 193 p. 58 h. 111

Italiancollectionsdiningroom 222

articolo **2162**
tavolo rettangolare con 2 allunghe cm. 40.
rectangular table with 2 extensions cm. 40.
cm. l. 160 p. 90 h. 82

articolo **2163**
sedia, chair.
cm. l. 50 p. 54 h. 102,5

articolo **2161**
argenteria 2 ante con ripiani in cristallo.
2 doors silvercase with crystal shelves.
cm. l. 156 p. 54 h. 211+14

articolo **2161/C**
cimasa optional per argenteria.
optional crown for silvercase.
cm. h. 14

223 Italiancollectionsdiningroom



Italiancollectionsdiningroom 224

Arredamento sala da pranzo: lo spazio della convivialità. Quando invitiamo parenti ed amici per una cena, facciamo di tutto per ospitarli al meglio, organizzando gli spazi affinché si possano rilassare e godere piacevolmente la serata. Tuttavia, ci piacerebbe che i nostri ospiti rimanessero sorpresi e affascinati dall'arredamento e dallo stile della nostra casa. Molti erroneamente sono portati a considerare "design" sinonimo di oggetti o completamenti che curano esclusivamente l'aspetto esteriore delle cose, lasciando in secondo piano la comodità o l'usabilità. In realtà non è così e presentiamo oggi una selezione di zone da pranzo di vario stile in cui funzionalità e design si fondono in modo armonioso e a cui potrete ispirarvi per creare ambienti d'effetto che lasceranno i vostri ospiti a bocca aperta. La tipica sala da pranzo intesa come locale a sé stante, adibito esclusivamente alla convivialità, può sembrare ormai retaggio di un modo di abitare piuttosto lontano rispetto alle attuali consuetudini. In epoca contemporanea, convenzioni sociali più informali o ritmi lavorativi frenetici che portano spesso a pranzare fuori casa e, soprattutto, metrature degli alloggi sempre più ridotte, fanno sì che raramente si possa disporre di un locale apposito per il pranzo. Ciò non toglie che, avendo lo spazio sufficiente, una sala pranzo separata dalla cucina, può essere utile per vivere al meglio le occasioni conviviali con amici e parenti o gli eventi più formali, come pranzi e cene di lavoro.

articolo **2160**
credenza 2 ante 4 cassetti con guide
ammortizzate. 2 doors sideboard
4 drawers with soft closing.
cm. l. 193 p. 58 h. 111

Dining room furniture: the space of conviviality. When we invite relatives and friends for a dinner, we do everything to accommodate them to the fullest, organizing the spaces so that they can relax and enjoy the evening pleasantly. However, we would like our guests to be surprised and fascinated by the decor and style of our home. Many are mistakenly led to consider "design" synonymous with objects or completions that exclusively take care of the external appearance of things, leaving comfort or usability in the background. In reality this is not the case and today we present a selection of dining areas of various styles in which functionality and design blend harmoniously and which you can inspire to create striking environments that will leave your guests speechless. The typical dining room intended as a separate room, used exclusively for conviviality, may now seem to be a legacy of a way of living rather far from current customs. In contemporary times, more informal social conventions or frenetic work rhythms that often lead to lunch outside the home and, above all, increasingly smaller sizes of accommodation, mean that it is rarely possible to have a special room for lunch. This does not mean that, having sufficient space, a dining room separate from the kitchen can be useful to better enjoy convivial occasions with friends and relatives or more formal events, such as business lunches and dinners.



articolo **2162**
tavolo rettangolare con 2 allunghe cm. 40.
rectangular table with 2 extensions cm. 40.
cm. l. 160 p. 90 h. 82

articolo **2163**
sedia. chair.
cm. l. 50 p. 54 h. 102,5

Iris

dining room design
classic furniture



225 Italiancollectionsdiningroom



dining room design
classic furniture

Sole

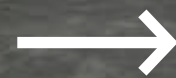

Italiancollectionsdiningroom 226

227 Italiancollectionsdiningroom

IL GIORNO



Sole

dining room design
classic furniture



Arredamento sala da pranzo: lo spazio della convivialità. Quando invitiamo parenti ed amici per una cena, facciamo di tutto per ospitarli al meglio, organizzando gli spazi affinché si possano rilassare e godere piacevolmente la serata. Tuttavia, ci piacerebbe che i nostri ospiti rimanessero sorpresi e affascinati dall'arredamento e dallo stile della nostra casa. Molti erroneamente sono portati a considerare "design" sinonimo di oggetti o complementi che curano esclusivamente l'aspetto esteriore delle cose, lasciando in secondo piano la comodità o l'usabilità. In realtà non è così e presentiamo oggi una selezione di zone da pranzo di vario stile in cui funzionalità e design si fondono in modo armonioso e a cui potrete ispirarvi per creare ambienti d'effetto che lasceranno i vostri ospiti a bocca aperta. La tipica sala da pranzo intesa come locale a sé stante, adibito esclusivamente alla convivialità, può sembrare ormai retaggio di un modo di abitare piuttosto lontano rispetto alle attuali consuetudini. In epoca contemporanea, convenzioni sociali più informali o ritmi lavorativi frenetici che portano spesso a pranzare fuori casa e, soprattutto, metrature degli alloggi sempre più ridotte, fanno sì che raramente si possa disporre di un locale apposito per il pranzo. Ciò non toglie che, avendo lo spazio sufficiente, una sala pranzo separata dalla cucina, può essere utile per vivere al meglio le occasioni conviviali con amici e parenti o gli eventi più formali, come pranzi e cene di lavoro.



Dining room furniture: the space of conviviality. When we invite relatives and friends for a dinner, we do everything to accommodate them to the fullest, organizing the spaces so that they can relax and enjoy the evening pleasantly. However, we would like our guests to be surprised and fascinated by the decor and style of our home. Many are mistakenly led to consider "design" synonymous with objects or completions that exclusively take care of the external appearance of things, leaving comfort or usability in the background. In reality this is not the case and today we present a selection of dining areas of various styles in which functionality and design blend harmoniously and which you can inspire to create striking environments that will leave your guests speechless. The typical dining room intended as a separate room, used exclusively for conviviality, may now seem to be a legacy of a way of living rather far from current customs. In contemporary times, more informal social conventions or frenetic work rhythms that often lead to lunch outside the home and, above all, increasingly smaller sizes of accommodation, mean that it is rarely possible to have a special room for lunch. This does not mean that, having sufficient space, a dining room separate from the kitchen can be useful to better enjoy convivial occasions with friends and relatives or more formal events, such as business lunches and dinners.

articolo **4083**
cornice, mirror.
cm. l. 170 sp. 2 h. 70

articolo **4080**
credenzona sagomato 2 ante 3 cassetti.
shaped sideboard 2 doors 3 drawers.
cm. l. 190 p. 55 h. 110



articolo **4081**
vetrina sagomata 2 ante.
2 doors shaped display case.
cm. l. 150 p. 50 h. 210

articolo **4082**
tavolo rettangolare allungabile.
rectangular extendable table.
cm. l. 160/240 p. 90 h. 80

articolo **784**
sedia, chair.
cm. l. 48 p. 58 h. 99

Sole



dining room design
classic furniture





articolo **233**
base 2 cassetti con rilievo.
2 drawers with relief base.
cm. l. 161 h. 64

articolo **236**
alzata 2 porte vetro liscio.
2 smooth glass doors showcase.
cm. l. 161 p. 54 h. 217

articolo **234**
credenza 2 porte con rilievo 4 cassetti.
2 doors with relief sideboard 4 drawers.
cm. l. 211 p. 60 h. 110

articolo **235**
tavolo rettangolare allungabile con
2 allunghe da cm. 40. extendable rectangular
table with 2 extensions cm. 40.
cm. l. 160 p. 85 h. 79 aperto. open. 240 x 90

articolo **674**
sedia. chair.
cm. l. 45 p. 52 h. 94



dining room design
classic furniture

←
Angela



Italiancollectionsdiningroom 234



235 Italiancollectionsdiningroom



articolo **233**
base 2 cassetti con rilievo.
2 drawers with relief base.
cm. l. 161 h. 64

articolo **236**
alzata 2 porte vetro liscio.
2 smooth glass doors showcase.
cm. l. 161 p. 54 h. 217

articolo **234**
credenza 2 porte con rilievo 4 cassetti.
2 doors with relief sideboard 4 drawers.
cm. l. 211 p. 60 h. 110

articolo **235**
tavolo rettangolare allungabile con
2 allunghe da cm. 40. extendable rectangular
table with 2 extensions cm. 40.
cm. l. 160 p. 85 h. 79 aperto. open. 240 x 90

articolo **674**
sedia. chair.
cm. l. 45 p. 52 h. 94

le Sale
dining room design
classic furniture



Charlotte

dining room design
classic furniture



articolo **1017**
credenza 3 porte con intarsio
2 cassetti e ribalta. 3 doors with inlay
sideboard 2 drawers and flap door.
cm. l. 223 p. 58 h. 122

Italiancollectionsdiningroom 236

articolo **1019**
tavolo rettangolare allungabile
2 allunghe da cm. 40. rectangular extendable
table with 2 extensions of cm. 40.
cm. l. 180/260 p. 90 h. 81

articolo **1020**
tavolo quadrato allungabile
2 allunghe da cm. 40. square extendable
table with 2 extensions of cm. 40.
cm. l. 105/185 p. 105 h. 81

articolo **784**
sedia. chair.
cm. l. 48 p. 53 h. 95

articolo **1018**
vetrina 2 porte con intarsio
e ripiani vetri. 2 doors with inlay
cabinet and glass shelves.
cm. l. 177,5 p. 48 h. 212,5

237 Italiancollectionsdiningroom



articolo **1017**
 credenza 3 porte con intarsio
 2 cassetti e ribalta. 3 doors with inlay
 sideboard 2 drawers and flap door.
 cm. l. 223 p. 58 h. 122

articolo **1019**
 tavolo rettangolare allungabile
 2 allunghe da cm. 40. rectangular extendable
 table with 2 extensions of cm. 40.
 cm. l. 180/260 p. 90 h. 81

articolo **1020**
 tavolo quadrato allungabile
 2 allunghe da cm. 40. square extendable
 table with 2 extensions of cm. 40.
 cm. l. 105/185 p. 105 h. 81



articolo **1021**
 sedia. chair.
 cm. l. 48 p. 51 h. 101

articolo **784**
 sedia. chair.
 cm. l. 48 p. 53 h. 95



articolo **1018**
 vetrina 2 porte con intarsio
 e ripiani vetri. 2 doors with inlay
 cabinet and glass shelves.
 cm. l. 177,5 p. 48 h. 212,5

dining room design
 classic furniture

Charlotte

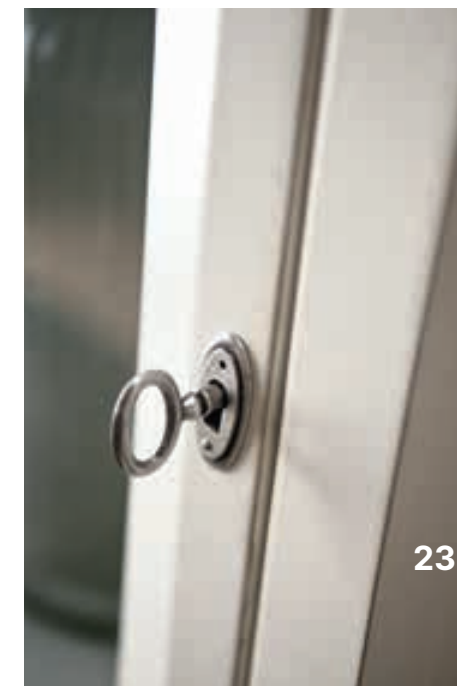

articolo **670**
credenza 2 porte con bugna
e traforo 3 cassetti. 2 perforated doors
sideboard with ashlar and 3 drawers.
cm. l. 201 p. 56 h. 117

articolo **670/L**
credenza 2 porte bugna liscia
3 cassetti. 2 beveled smooth doors
sideboard and 3 drawers.
cm. l. 201 p. 56 h. 117

articolo **673**
tavolo rettangolare allungabile inciso.
graven extensible rectangular table.
cm. l. 160/240 p. 85 h. 81

articolo **674**
sedia. chair. cm. l. 45 p. 52 h. 94

articolo **673/L**
tavolo rettangolare allungabile liscio.
smooth rectangular extensible table.
cm. l. 160/240 p. 85 h. 81

articolo **671**
argenteria 2 porte con bugna e traforo.
2 beveled perforated doors display cabinet.
cm. l. 166 p. 51 h. 214

articolo **671/L**
argenteria 2 porte con bugna liscia.
2 beveled smooth doors display cabinet.
cm. l. 166 p. 51 h. 214





articolo **670**
 credenza 2 porte con bugna
 e traforo 3 cassetti. 2 perforated doors
 sideboard with ashlar and 3 drawers.
 cm. l. 201 p. 56 h. 117

articolo **670/L**
 credenza 2 porte bugna liscia
 3 cassetti. 2 beveled smooth doors
 sideboard and 3 drawers.
 cm. l. 201 p. 56 h. 117

articolo **436**
 specchiera rettangolare traforata.
 rectangular perforated mirror.
 cm. l. 180 sp. 1,2 h. 90



articolo **673**
 tavolo rettangolare allungabile inciso.
 graven extensible rectangular table.
 cm. l. 160/240 p. 85 h. 81

articolo **674**
 sedia. chair. cm. l. 45 p. 52 h. 94

articolo **673/L**
 tavolo rettangolare allungabile liscio.
 smooth rectangular extendable table.
 cm. l. 160/240 p. 85 h. 81

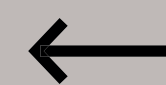

le Sale
 dining room design
 classic furniture

dining room design
classic furniture

le Sale →



articolo **2182**
specchiera rettangolare.
rectangular mirror.
cm. l. 180 h. 90

articolo **2180**
credenza 2 porte con bugna
e traforo 3 cassetti. 2 perforated doors
sideboard with ashlar and 3 drawers.
cm. l. 201 p. 56 h. 117

articolo **2184**
tavolo rettangolare allungabile liscio.
smooth rectangular extendable table.
cm. l. 160/240 p. 85 h. 81

articolo **2183**
sedia. chair. cm. l. 45 p. 52 h. 94

articolo **2181**
argenteria 2 porte con bugna
e traforo. 2 beveled perforated doors
display cabinet with ashlar.
cm. l. 166 p. 51 h. 214

articolo **963**
credenza 3 porte con rilievo 2 cassetti.
3 doors with relief sideboard 2 drawers.
cm. l. 196 p. 50 h. 110

articolo **962**
argenteria 2 porte con rilievo.
2 doors with relief display cabinet.
cm. l. 162 p. 54 h. 217

articolo **868**
tavolo rettangolare allungabile
2 allunghe da cm. 40. extendable rectangular
table with 2 extensions cm. 40.
cm. l. 160 p. 85 h. 80
aperto. open. 240 x 85

articolo **869**
sedia. chair. cm. l. 43 p. 48 h. 93



Matilde

dining room design
classic furniture



IL GIORNO



dining room design
classic furniture

Matilde

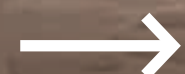

articolo **963**
credenza 3 porte con rilievo 2 cassetti.
3 doors with relief sideboard 2 drawers.
cm. l. 196 p. 50 h. 110



Arredare la casa in stile classico è una scelta che non tradisce mai, arricchire la casa con mobili eleganti e materiali preziosi permette di godere di un'atmosfera sobria e raffinata ed all'interno di questo arredamento dai toni chic un ruolo importante lo giocano i tavoli classici. I tavoli in legno dallo stile classico hanno un fascino senza tempo, sono belli, ricercati, realizzati in modo artigianale, sono dei pezzi d'arredo di alta qualità, che si accostano benissimo ad altri elementi del medesimo stile ma anche ad arredi più moderni e dal gusto più contemporaneo. Chi ha la fortuna di ereditare un tavolo antico, appartenuto ai propri avi, oltre ad avere nel proprio soggiorno un pezzo unico e raro da un punto di vista qualitativo, ha anche un elemento dall'alto valore sentimentale, un oggetto dei ricordi, un pezzo della propria vita, ricco di simboli e valori affettivi. L'obbiettivo è dunque quello di valorizzarlo, renderlo protagonista del living, porlo al centro dell'attenzione, e questo lo si può fare prima di tutto con un delicato e meticoloso restauro che possa restituire l'originario splendore al tavolo e sottolineando la sua presenza all'interno del salotto con l'aggiunta di un bel centrotavola, che possa mettere in evidenza tutte le potenzialità del pezzo. Adornarlo con sedie anche a contrasto stilistico potrebbe essere la carta vincente del progetto d'arredo, sedie che saranno magari moderne e discrete, possibilmente in materiale plastico e trasparente, al fine di esaltare gli intagli e le lavorazioni artigianali del tavolo classico.

Furnishing the house in a classic style is a choice that never betrays, enriching the house with elegant furniture and precious materials allows you to enjoy a sober and refined atmosphere and within this chic-toned furniture an important role is played by the tables classics. The classic style wooden tables have a timeless appeal, they are beautiful, refined, made in a traditional way, they are high quality pieces of furniture, which match very well with other elements of the same style but also with more modern furnishings. with a more contemporary taste. Those who are lucky enough to inherit an antique table, which belonged to their ancestors, as well as having in their living room a unique and rare piece from a qualitative point of view, also has an element of high sentimental value, an object of memories, a piece of one's life, rich in symbols and affective values. The goal is therefore to enhance it, make it the protagonist of the living, place it at the center of attention, and this can be done first of all with a delicate and meticulous restoration that can restore the original splendor to the table and underlining its presence inside the living room with the addition of a beautiful centerpiece, which can highlight all the potential of the piece. Adorn it with chairs also in stylistic contrast could be the winning card of the furnishing project, chairs that may be modern and discreet, possibly in plastic and transparent material, in order to enhance the carvings and the craftsmanship of the classic table.

articolo **868**
tavolo rettangolare allungabile
2 allunghe da cm. 40. extendable rectangular
table with 2 extensions cm. 40.
cm. l. 160 p. 85 h. 80
aperto. open. 240 x 85



gambe pe tavolo disponibili.
legs for table available.

articolo **614**
tavolo quadrato allungabile a libro.
square extendable folding table.
cm. l. 100 p. 100 h. 80
aperto. open. 200 x 100



le Sale



dining room design
classic furniture

articolo **860**
credenza 2 porte con intarsio 2 cassetti.
2 doors with inlay sideboard 2 drawers.
cm. l. 200 p. 50 h. 106

articolo **865**
argenteria 2 porte con intarsio vetro liscio.
2 smooth glass doors inlay display cabinet.
cm. l. 150 p. 48 h. 215

articolo **868**
tavolo rettangolare liscio allungabile
con 2 allunghe da cm. 40.
extendable rectangular smooth table
with 2 extensions cm. 40.
cm. l. 160/240 p. 85 h. 80

articolo **869**
sedia. chair. cm. l. 43 p. 48 h. 93



dining room design
classic furniture

le Sale



articolo **001/T**
credenza 2 ante 6 cassetti
con pannello traforato. 2 doors sideboard
6 drawers with perforated panel
cm. l. 195 p. 58 h. 101

articolo **002/T**
argenteria 2 ante con pannello traforato
2 doors glass cabinet with perforated panel
cm. l. 158 p. 50 h. 218

articolo **005**
tavolo con 2 cassetti allungabile
e 2 allunghe da cm. 50. extendable table
with 2 drawers 2 extensions cm. 50.
cm. l. 160/260 p. 90 h. 80

articolo **006**
sedia. chair. cm. l. 40 p. 45 h. 83



articolo **001/T**
credenza 2 ante 6 cassetti
con pannello traforato. 2 doors sideboard
6 drawers with perforated panel.
cm. l. 195 p. 58 h. 101

articolo **005**
tavolo con 2 cassetti allungabile
e 2 allunghe da cm. 50. extendable table
with 2 drawers 2 extensions cm. 50.
cm. l. 160/260 p. 90 h. 80

articolo **002/T**
argenteria 2 ante con pannello traforato
2 doors glass cabinet with perforated panel
cm. l. 158 p. 50 h. 218

articolo **007**
sedia. chair. cm. l. 47 p. 48 h. 96,5



IL GIORNO

le Sale

dining room design
classic furniture

articolo **815**
tavolo rettangolare allungabile con
2 allunghe da cm. 40. extendable rectangular
table with 2 extensions cm. 40.
cm. l. 160 p. 85 h. 80
aperto. open. 240 x 85

articolo **816**
tavolo quadrato allungabile.
square extendable table.
cm. l. 110 p. 110 h. 85
aperto. open. 220 x 100

articolo **869**
sedia. chair. cm. l. 43 p. 48 h. 93

articolo **840**
credenzona 2 ante con bugna intagliata
4 cassetti e segreto. 2 doors sideboard
beveled carved 4 drawers and secret.
cm. l. 225 p. 58 h. 118

articolo **856**
argenteria 2 ante con bugna intagliata.
2 doors silver case with beveled carved.
cm. l. 154 p. 50 h. 214

articolo **845**
credenzone 2 ante con bugna
intagliata 2 cassetti. 2 doors sideboard
with beveled carved 2 drawers.
cm. l. 184 p. 58 h. 118

articolo **846**
credenzone 2 ante con pannello liscio
2 cassetti e segreto. 2 doors sideboard
smooth panel 2 drawers and secret.
cm. l. 184 p. 58 h. 118



articolo **840**
credenzone 2 ante con bugna intagliata
4 cassetti e segreto. 2 doors sideboard
beveled carved 4 drawers and secret.
cm. l. 225 p. 58 h. 118

articolo **841**
credenzone 2 ante con pannello liscio
4 cassetti e segreto. 2 doors sideboard
smooth panel 4 drawers and secret.
cm. l. 225 p. 58 h. 118



articolo **856**
argenteria 2 ante con bugna intagliata.
2 doors silver case with beveled carved.
cm. l. 154 p. 50 h. 214

articolo **857**
argenteria 2 ante pannello liscio.
2 doors silver case with smooth panel.
cm. l. 154 p. 50 h. 214

articolo **855**
argenteria 2 ante tutte vetro.
2 all glass doors silver case.
cm. l. 154 p. 50 h. 214



articolo **850**
argenteria grande 2 ante tutte vetro.
2 all glass doors big silver case.
cm. l. 184 p. 50 h. 214

dining room design
classic furniture

le Sale →

le Sale

dining room design
classic furniture



articolo **207**
credenza 4 ante con bugna.
sideboard with 4 beveled doors.
cm. l. 204 p. 47 h. 97

articolo **208**
cristalliera 2 ante con bugna.
glass case with 2 beveled doors.
cm. l. 109 p. 47 h. 218

articolo **101/A**
alzata 2 ante vetro.
showcase 2 glass doors.



articolo **202**
credenza 2 ante con bugna.
sideboard with 2 beveled doors.
cm. l. 109 p. 47 h. 97



articolo **204**
credenza 3 ante con bugna.
sideboard with 3 beveled doors.
cm. l. 162 p. 47 h. 97

articolo **639**
sedia. chair. cm. l. 44 p. 46 h. 96

articolo **104**
credenza 4 ante liscie.
sideboard with 4 smooth doors.
cm. l. 204 p. 47 h. 97

articolo **100**
credenza 3 ante liscie.
sideboard with 3 smooth doors.
cm. l. 162 p. 47 h. 97

articolo **103**
cristalliera 3 ante liscie.
glass case with 3 smooth doors.
cm. l. 162 p. 47 h. 218

articolo **103/A**
alzata 3 ante vetro.
showcase 3 glass doors.

articolo **105**
cristalliera 4 ante con liscie.
glass case with 4 smooth doors.
cm. l. 204 p. 47 h. 218

articolo **105/A**
alzata 4 ante vetro.
showcase 4 glass doors.



dining room design
classic furniture

le Sale →



articolo **2163**
sedia. chair. cm. l. 50 p. 54 h. 102,5



articolo **639**
sedia. chair. cm. l. 44 p. 46 h. 96



articolo **869**
sedia. chair. cm. l. 43 p. 48 h. 93

our chairs design
classic furniture



sedie per composizioni. chairs for composition.



articolo **1021**
sedia. chair. cm. l. 48 p. 51 h. 101



articolo **784**
sedia. chair. cm. l. 48 p. 58 h. 99



articolo **007**
sedia. chair. cm. l. 46 p. 48 h. 96,5

IL GIORNO



articolo **674**
sedia. chair. cm. l. 45 p. 52 h. 94



articolo **903**
sedia. chair. cm. l. 47,5 p. 53 h. 95,5



articolo **2183**
sedia. chair. cm. l. 45 p. 52 h. 94



articolo **953**
sedia. chair. cm. l. 52 p. 52 h. 104



articolo **006**
sedia. chair. cm. l. 40 p. 45 h. 83

le Sedie

dining room design
classic furniture





bathroom furniture
classic design



I bagni



mobili bagno
specchiere

bathroom furniture
classic design



i Bagni

articolo **BOTTICELLI**
mobile bagno sagomato 2 cassetti.
shaped bathroom cabinet 2 drawers.
cm. l. 180 p. 63 h. 85

articolo **438**
specchiera sagomata, shaped mirror.
cm. l. 75 h. 110

articolo **439**
specchiera sagomata, shaped mirror.
cm. l. 90 h. 120



bathroom furniture
classic design

Botticelli



articolo **MANTEGNA**
mobile bagno sagomato 3 cassetti.
shaped bathroom cabinet 3 drawers.
cm. l. 120 p. 63 h. 85

articolo **417**
specchiera traforata, perforated mirror.
cm. l. 67 sp. 1,1 h. 100

Mantegna

bathroom furniture
classic design





←
Caravaggio

bathroom furniture
classic design

articolo **CARAVAGGIO**
mobile bagno sagomato 2 cassetti.
shaped bathroom cabinet 2 drawers.
cm. l. 120 p. 60 h. 88

articolo **441**
specchiera traforata, perforated mirror.
cm. l. 116 sp. 1,2 h. 58



articolo **GIOTTO**
mobile bagno sagomato 3 cassetti.
shaped bathroom cabinet 3 drawers.
cm. l. 120 p. 63 h. 85

articolo **403**
specchiera traforata, perforated mirror.
cm. l. 92 sp. 1,1 h. 92



bathroom furniture
classic design

← **Giotto**

articolo **MICHELANGELO**
mobile bagno sagomato 3 cassetti.
shaped bathroom cabinet 3 drawers.
cm. l. 120 p. 58 h. 86

articolo **410**
specchiera traforata, perforated mirror.
cm. l. 80 sp. 1,3 h. 109

← Michelangelo

bedroom design
contemporary



articolo **RAFFAELLO**
mobile bagno sagomato 3 cassetti.
shaped bathroom cabinet 3 drawers.
cm. l. 120 p. 55 h. 95

articolo **433**
specchiera traforata, perforated mirror.
cm. l. 83 sp. 1,1 h. 108

bathroom design
classic furniture

Raffaello →



Ecopelli



imbottiture per letti upholstered for beds

Scegliere l'imbottitura per la testiera per la camera matrimoniale è una decisione di estrema importanza per creare quell'atmosfera delicata, di classe e accogliente che in questa parte della casa non può assolutamente mancare. Prova ad immaginare un letto matrimoniale a cui manchi la testiera, si ha subito la sensazione di un letto misero e banale. Invece è incredibile come sia sufficiente aggiungere una testiera per rendere il letto completamente trasformato. Proprio come una corona che, messa sul capo del principe, lo fa diventare re. Il paragone non è fuori luogo se si considera che la testata coincide esattamente con la testa del letto, dunque la sua parte più importante. Se poi si parla di letto matrimoniale, nella camera padronale della casa, allora non esiste metafora più appropriata.

Choosing the padding for the headboard for the double bedroom is an extremely important decision to create that delicate, classy and welcoming atmosphere that cannot be missing in this part of the house. Try to imagine a double bed that is missing the headboard, you immediately have the feeling of a miserable and banal bed. Instead it is amazing how it is enough to add a headboard to make the bed completely transformed. Just like a crown that, placed on the prince's head, makes him king. The comparison is not out of place if we consider that the headboard coincides exactly with the head of the bed, therefore its most important part. If then we speak of a double bed, in the master bedroom of the house, then there is no more appropriate metaphor.



RENNA colore 25 color



RENNA colore 61 color



RENNA colore 50 color

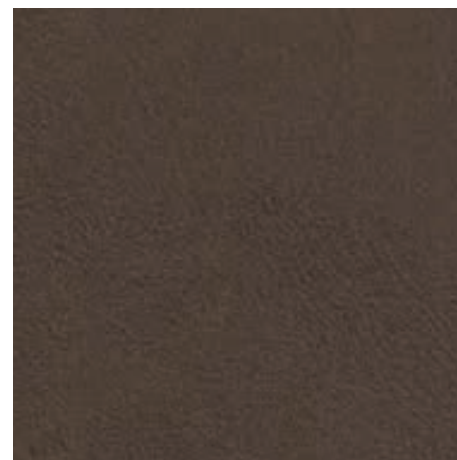

RENNA colore 64 color

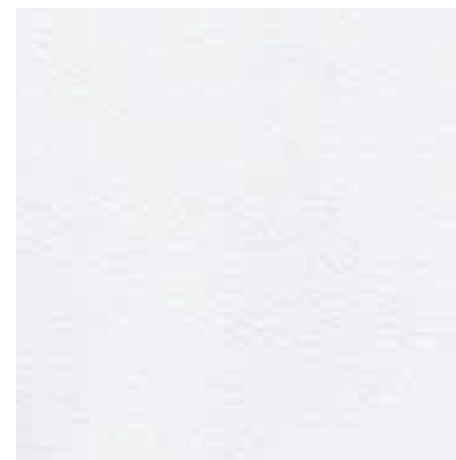

colore BIANCO WHITE color



colore AVORIO IVORY color

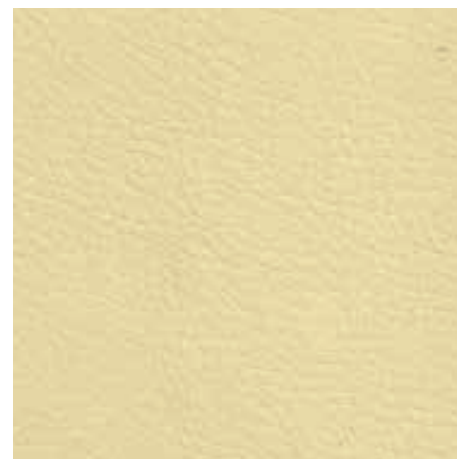

colore CREMA CREAM color

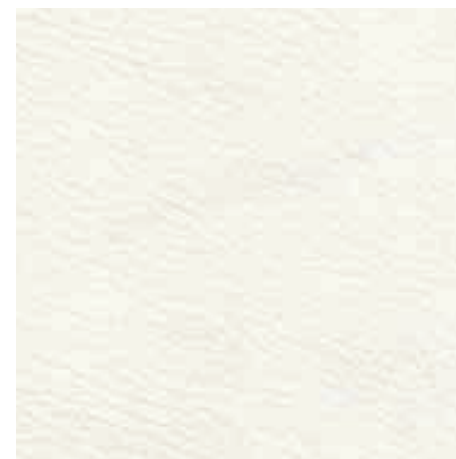

colore PANNA CREAM color

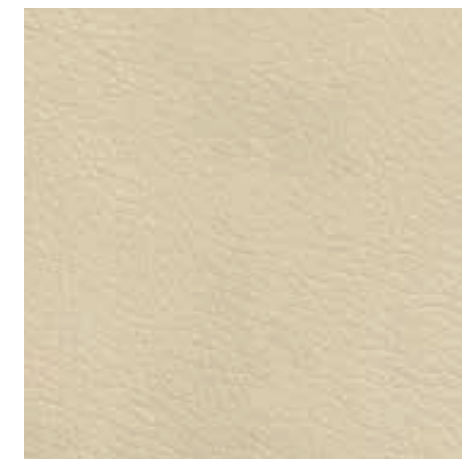

colore BEIGE BEIGE color

bedroom design contemporary



la Notte

comò
specchiere
comodini
letti
armadi
cabine armadio

Bedroom design contemporary



la Notte



in tangerina
con inserti frassino



Marica

bedroom design
contemporary



LA NOTTE



in tangamica
con inserti frassino

Marica

bedroom design
contemporary

articolo **3000**
armadio 2 ante scorrevoli
in TANGANICA con inserti in FRASSINO.
2 sliding doors wardrobe
in TANGANYIKA with ASH WOOD inserts.
cm. l. 274 p. 66 h. 248



STRISCIE AL LED (OPTIONAL).
LED STRIPS (OPTIONAL).

articolo **3001**
armadio 2 ante scorrevoli
in **TANGANICA** con inserti in **FRASSINO**
e specchi lisci. 2 sliding doors wardrobe
in **TANGANYIKA** with **ASH WOOD**
inserts and smooth mirrors.
cm. l. 274 p. 66 h. 248

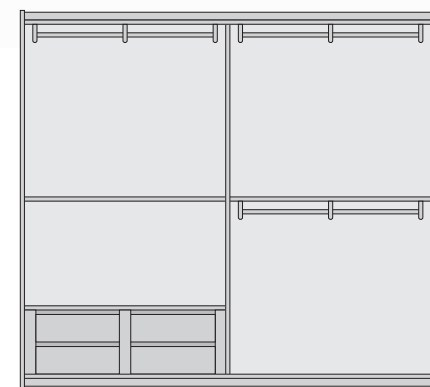

armadio disposizione interna di serie.
wardrobe internal layout as standard.

bedroom design
contemporary

Marica

in tanganica con inserti frassino



Italiancollectionsbedroom 282



LA NOTTE

283 Italiancollectionsbedroom

in tangamica
con inserti frassino

Sonia

bedroom design
contemporary



LA NOTTE

Le camere da letto complete comprendono tutta una serie di complementi arredo zona notte che compongono un progetto di arredamento già ben definito. Una camera da letto moderna, interamente in legno massello di frassino che abbina la qualità del legno, al gusto ed alle tendenze attuali. La soluzione giusta per chi cerca uno stile duraturo, dalle linee morbide e delicate. Il legno è la chiave predominante della composizione, con le sue tante finiture frassinate a scelta del cliente e la particolare maniglia curva cromata, montata in modo sfalsato per creare un particolare gioco di forme nei cassetti del comò e dei comodini.

The complete bedrooms include a whole series of bedroom furniture complements that make up a well-defined furnishing project. Is a modern bedroom, entirely in solid ash wood that combines the quality of wood, taste and current trends. The right solution for those looking for a lasting style, with soft and delicate lines. Wood is the predominant key of the composition, with its many ash finishes chosen by the customer and the particular chrome-plated curved handle, mounted in a staggered way to create a particular play of shapes in the dresser and bedside drawers.



pedini disponibili →
available legs



PIEDINO ACCIAIO. cm. h. 17



GAMBA DRITTA ACCIAIO. cm. h. 13.



GAMBA VETRO. cm. h. 17.



PIEDINO METALLO. cm. h. 17.



BASAMENTO LEGNO. cm. h. 6.



articolo 3000
armadio 2 ante scorrevoli in TANGANICA con inserti in FRASSINO. 2 sliding doors wardrobe in TANGANYIKA with ASH WOOD inserts.
cm. l. 274 p. 66 h. 248



articolo 3001
armadio 2 ante scorrevoli in TANGANICA con inserti in FRASSINO e specchi lisci. 2 sliding doors wardrobe in TANGANYIKA with ASH WOOD inserts and smooth mirrors.
cm. l. 274 p. 66 h. 248



articolo 3010
coppia led con sensore di movimento per armadio. led pair with motion sensor for wardrobe.

bedroom design contemporary



←
in tanganica
con inserti frassino
tanganyika
with ash inserts



articolo 3002
letto matrimoniale con testata legno in TANGANICA con inserti in FRASSINO (rete da 160 x 195). double bed with wooden headboard in TANGANYIKA with ASH WOOD inserts (bed base 160 x 195).
cm. l. 173 p. 210 h. 110



articolo 3003
letto matrimoniale in TANGANICA con inserti in FRASSINO e pannello imbottito (rete da 160 x 195). double bed ASH WOOD in TANGANYIKA with ASH WOOD inserts and upholstered panel (bed base 160 x 195).
cm. l. 173 p. 210 h. 110

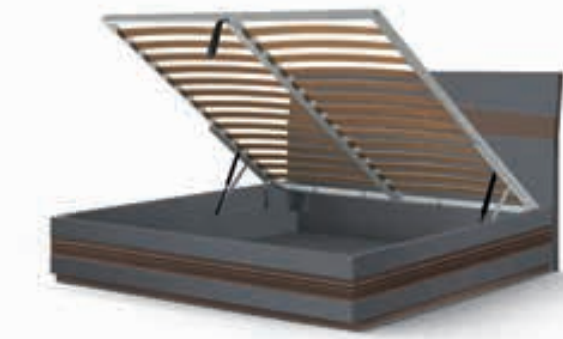

articolo 3004
giroletto in TANGANICA con inserti in FRASSINO. e contenitore interno meccanismo alzata verticale. (rete da 160 x 195). bed frame in TANGANYIKA with ASH WOOD and internal container with vertical lift mechanism (bed base 160 x 195).



articolo 3005
comò 3 cassetti in TANGANICA con inserti in FRASSINO, guide PUSH and PULL, stabilizzatore e zoccolo. chest of 3 drawers in TANGANYIKA with ASH WOOD inserts, PUSH and PULL guides, stabilizer and basemet.
cm. l. 130 p. 55 h. 85,5



articolo 3006
comodino 2 cassetti in TANGANICA con inserti in FRASSINO, guide PUSH and PULL e zoccolo. bedside table 2 drawers in TANGANYIKA with ASH WOOD inserts, PUSH and PULL guides and basemet.
cm. l. 58 p. 40 h. 45



articolo 3007
cornice rettangolare in TANGANICA con inserti in FRASSINO e specchio liscio. rectangular frame in TANGANYIKA with ASH WOOD inserts and smooth mirror.
cm. l. 110 sp. 2,7 h. 60



articolo 3008
comò 3 cassetti in TANGANICA con inserti in FRASSINO, guide PUSH and PULL, stabilizzatore e piedini in metallo. chest of 3 drawers in TANGANYIKA with ASH WOOD inserts, PUSH and PULL guides, stabilizer and metal legs.
cm. l. 130 p. 55 h. 97



set stabilizzatore laterale di serie migliora la stabilità dei cassetti del comò. lateral stabilizer set as standard improves the stability of chest of drawers.

articolo 3009
comodino 2 cassetti in TANGANICA con inserti in FRASSINO, guide PUSH and PULL e piedini in metallo. bedside table 2 drawers in TANGANYIKA with ASH WOOD inserts, PUSH and PULL guides and metal legs.
cm. l. 58 p. 40 h. 57

bedroom design
contemporary

Alessia

in frassino

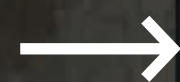

LA NOTTE



bedroom design
contemporary

Alessia

in frassino



articolo **3015**
armadio 2 ante scorrevoli in FRASSINO
con specchi lisci. 2 sliding doors wardrobe
in ASH WOOD with smooth mirrors.
cm. l. 274 p. 66 h. 248

articolo **3020**
comò 3 cassetti in FRASSINO con guide
ammortizzate, maniglie legno e piedini metallo.
chest of 3 drawers in ASH WOOD with soft
closing, wooden handles and metal legs.
cm. l. 130 p. 55 h. 92

Gli armadi ad ante scorrevoli sono funzionali e pratici per il risparmio di spazio che deriva dall'assenza di ante in apertura. Armadio dallo stile moderno e dalle linee pulite ed essenziali ideale se si vuole dare luminosità alla propria camera da letto. Tutto ciò che necessita di ordine trova posto in questo armadio ad ante scorrevoli. Il design di questo armadio lo rende perfetto per ogni tipo di camera da letto. L'armadio è dotato di due ante a specchio che scorrono su guide in metallo che garantiscono efficienza e una diminuzione dei danni legati all'usura.

Sliding door wardrobes are functional and practical due to the space saving that comes from the absence of opening doors. Wardrobe with a modern style and clean and essential lines, ideal if you want to give brightness to your bedroom. Everything that needs order finds a place in this wardrobe with sliding doors. The design of this wardrobe makes it perfect for any type of bedroom. The wardrobe is equipped with two mirrored doors that slide on metal guides which guarantee efficiency and a reduction in damage caused by wear.

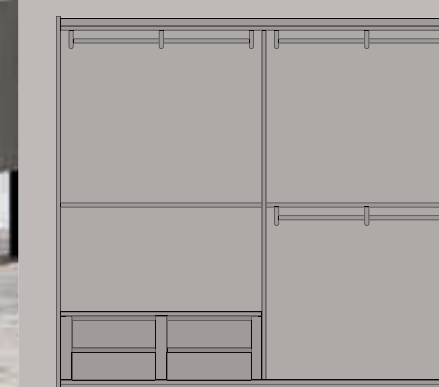

armadio disposizione interna di serie.
wardrobe internal layout as standard.



articolo **3017**
 armadio 2 ante scorrevoli legno.
 2 wooden sliding doors wardrobe.
 cm. l. 274 p. 66 h. 248

Alessia



bedroom design
 contemporary

in frassino

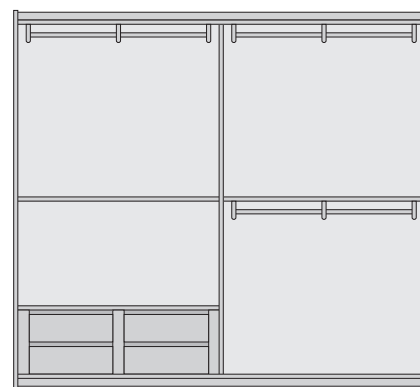

articolo **3016**
 armadio 2 ante scorrevoli in FRASSINO
 con specchi lisci. 2 sliding doors wardrobe
 in ASH WOOD with smooth mirrors.
 cm. l. 274 p. 66 h. 248

armadio disposizione interna di serie.
 wardrobe internal layout as standard.



LA NOTTE



in frassino

Alessia

bedroom design
contemporary

articolo **3018**
letto matrimoniale in FRASSINO con testata imbottita/legno (rete da 160 x 195).
double bed in ASH WOOD with upholstered /wooden headboard (bed base 160 x 195).
cm. l. 173 p. 210 h. 110

articolo **3024**
comò 3 cassetti in FRASSINO con guide ammortizzate, maniglie legno e zoccolo.
chest of 3 drawers in ASH WOOD with soft closing, wooden handles and base.
cm. l. 130 p. 55 h. 80,5

articolo **3025**
comodino SX 2 cassetti in FRASSINO con guide ammortizzate, maniglie legno e zoccolo.
SX bedside table 2 drawers in ASH WOOD with soft closing, wooden handles and base.
cm. l. 58 p. 40 h. 45,5

articolo **3026**
comodino DX 2 cassetti in FRASSINO con guide ammortizzate, maniglie legno e zoccolo.
DX bedside table 2 drawers in ASH WOOD with soft closing, wooden handles and base.
cm. l. 58 p. 40 h. 45,5

bedroom design contemporary



elementi singoli in frassino per camera individual ash elements for bedroom



articolo **3015**
armadio 2 ante scorrevoli in FRASSINO con specchi lisci. 2 sliding doors wardrobe in ASH WOOD with smooth mirrors.
cm. l. 274 p. 66 h. 248



articolo **3016**
armadio 2 ante scorrevoli in FRASSINO con specchi lisci. 2 sliding doors wardrobe in ASH WOOD with smooth mirrors.
cm. l. 274 p. 66 h. 248



articolo **3017**
armadio 2 ante scorrevoli legno in FRASSINO. 2 wooden sliding doors wardrobe in ASH WOOD.
cm. l. 274 p. 66 h. 248



articolo **3018**
letto matrimoniale in FRASSINO con testata imbottita/legno (rete da 160 x 195). double bed in ASH WOOD with upholstered/wooden headboard (bed base 160 x 195).
cm. l. 173 p. 210 h. 110

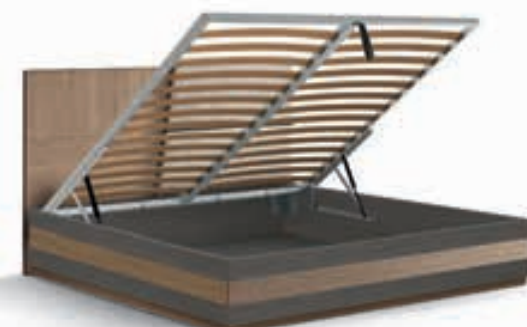

articolo **3019**
giroletto in FRASSINO con contenitore interno meccanismo alzata verticale (rete da 160 x 195). bed frame in ASH WOOD with internal container with vertical lift mechanism (bed base 160 x 195).



articolo **3020**
comò 3 cassetti in FRASSINO con guide ammortizzate, maniglie legno e piedini metallo. chest of 3 drawers in ASH WOOD with soft closing, wooden handles and metal legs.
cm. l. 130 p. 55 h. 92



articolo **3021**
comodino SX 2 cassetti in FRASSINO con guide ammortizzate, maniglie legno e piedini metallo. SX bedside table 2 drawers in ASH WOOD with soft closing, wooden handles and metal legs.
cm. l. 58 p. 40 h. 57



articolo **3022**
comodino DX 2 cassetti in FRASSINO con guide ammortizzate, maniglie legno e piedini metallo. DX bedside table 2 drawers in ASH WOOD with soft closing, wooden handles and metal legs.
cm. l. 58 p. 40 h. 57



articolo **3023**
cornice rettangolare in FRASSINO con specchio liscio. rectangular frame in ASH WOOD with smooth mirror.
cm. l. 110 sp. 2,7 h. 60



articolo **3024**
comò 3 cassetti in FRASSINO con guide ammortizzate, maniglie legno e zoccolo. chest of 3 drawers in ASH WOOD with soft closing, wooden handles and base.
cm. l. 130 p. 55 h. 80,5



articolo **3025**
comodino SX 2 cassetti in FRASSINO con guide ammortizzate, maniglie legno e zoccolo. SX bedside table 2 drawers in ASH WOOD with soft closing, wooden handles and base.
cm. l. 58 p. 40 h. 45,5



articolo **3026**
comodino DX 2 cassetti in FRASSINO con guide ammortizzate, maniglie legno e zoccolo. DX bedside table 2 drawers in ASH WOOD with soft closing, wooden handles and base.
cm. l. 58 p. 40 h. 45,5



piedini disponibili available legs



PIEDINO ACCIAIO. cm. h. 17



GAMBA DRITTA ACCIAIO. cm. h. 13.

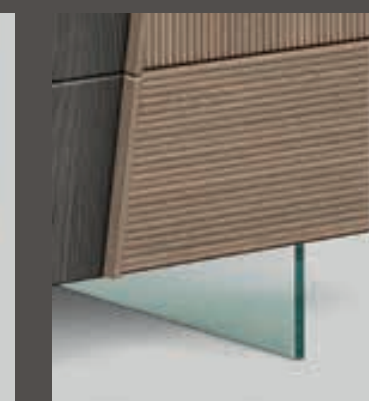

GAMBA VETRO. cm. h. 17.



PIEDINO METALLO. cm. h. 17.



BASAMENTO LEGNO. cm. h. 6.

bedroom design
contemporary

Virginia

in frassino

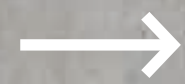

LA NOTTE



in frassino
Virginia
bedroom design
contemporary

Composizione armadio ad anta battente in cui la semplicità della finitura in frassino incontra il design delle sottili gole verticali. L'accostamento delle superfici che richiamano l'effetto naturale del legno, rendono l'arredo attuale ed eclettico per ogni atmosfera della zona notte. Gli armadi di questa collezione possono essere accostati a piacimento ad esempio (per formare un armadio 8 ante basta accostare 2 armadi da 4 ante ovviamente tra i due armadi ci sarà un doppio fianco. Arredamenti personalizzati in ogni dettaglio. Rivolgendoti a noi puoi decidere ogni dettaglio e ogni finitura dei tuoi arredamenti, dai materiali alle tinte agli accessori, senza dover scendere a compromessi.

Wardrobe composition with hinged door in which the simplicity of the ash finish meets the design of the thin vertical grooves. The combination of surfaces that recall the natural effect of wood makes the furnishings current and eclectic for any atmosphere in the sleeping area. The wardrobes in this collection can be combined as desired, for example (to form an 8 doors wardrobe, simply place 2 of 4 doors wardrobes side by side, obviously there will be a double side between the two wardrobes. Furnishings customized in every detail. By contacting us you can decide every detail and every finish of your furnishings, from materials to colors to accessories, without having to make compromises.



Italiancollectionsbedroom 302

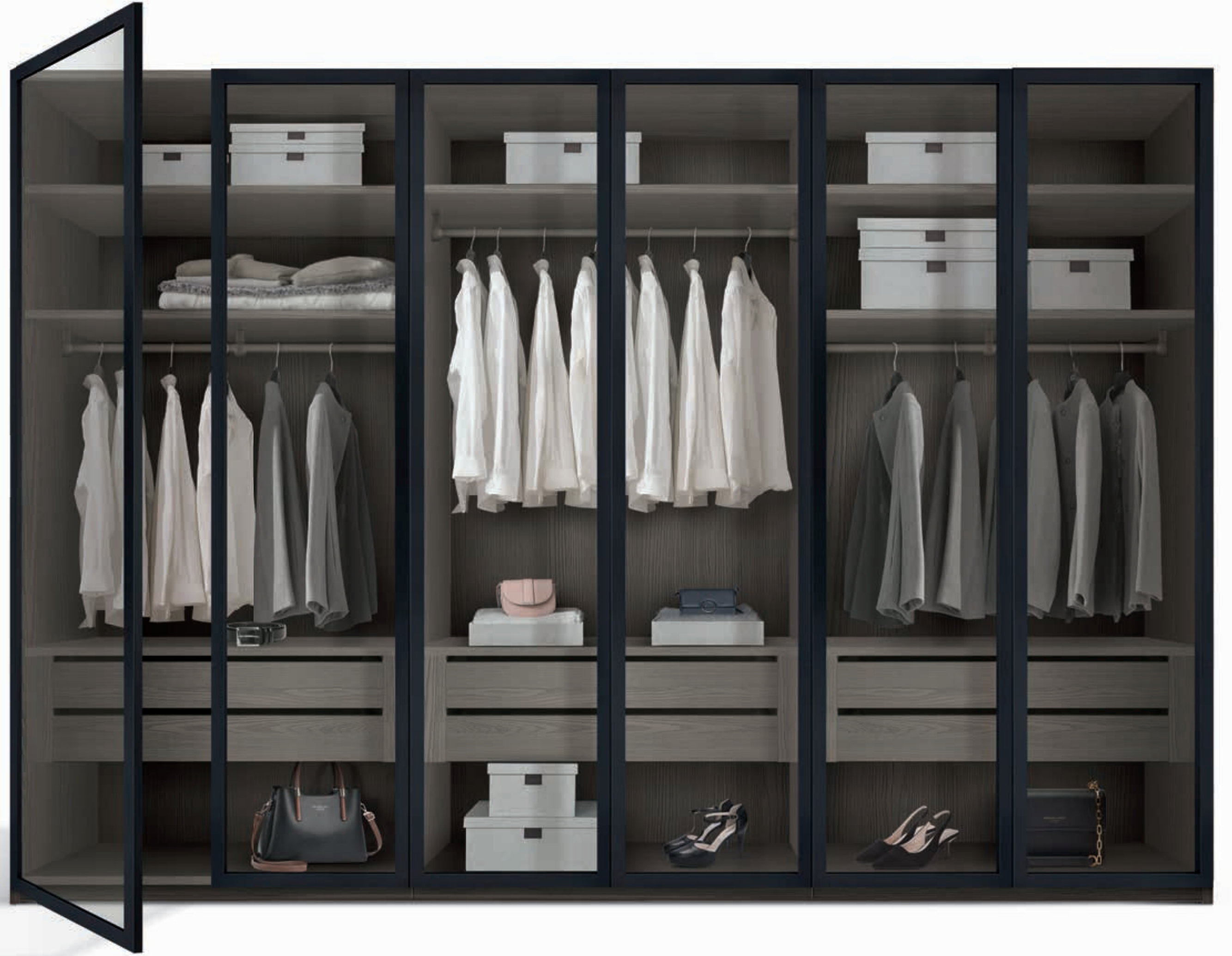

303 Italiancollectionsbedroom



articolo **3200**
scocca armadio 1 anta battente.
1 hinged door wardrobe frame.
cm. l. 58 p. con ante 57 h. 248



articolo **3201**
scocca armadio 2 ante battenti.
2 hinged doors wardrobe frame.
cm. l. 115 p. con ante 57 h. 248



articolo **3202**
scocca armadio 3 ante battenti.
3 hinged doors wardrobe frame.
cm. l. 173 p. con ante 57 h. 248



articolo **3203**
scocca armadio 4 ante battenti.
4 hinged doors wardrobe frame.
cm. l. 231 p. con ante 57 h. 248



articolo **3204**
scocca armadio 5 ante battenti.
5 hinged doors wardrobe frame.
cm. l. 289 p. con ante 57 h. 248



articolo **3205**
scocca armadio 6 ante battenti.
6 hinged doors wardrobe frame.
cm. l. 346 p. con ante 57 h. 248



articolo **3206**
armadio pensile 2 ante battenti cassetiera
e pannello girevole. 2 hinged doors wardrobe
drawers dresser and rotating panel.
cm. l. 115 p. con ante 57 h. 248



articolo **3207**
anta in legno con gola.
wooden door with groove.



articolo **3208**
anta in metallo con vetro
trasparente o Stop-Sol. metal door
with transparent or Stop-Sol glass.



articolo **3209**
ripiano lungo. long shelf. cm. sp. 2,5



articolo **3211**
cassetiera interna lunga 3 cassetti.
long internal dresser 3 drawers.



articolo **3213**
cassetiera interna lunga 2 cassetti.
long internal dresser 2 drawers.



articolo **3210**
ripiano corto. short shelf. cm. sp. 2,5



articolo **3212**
cassetiera interna corta 3 cassetti.
short internal dresser 3 drawers.



articolo **3214**
cassetiera interna corta 2 cassetti.
short internal dresser 2 drawers.

bedroom design
contemporary
Virginia
in frassino



La soluzione giusta per chi cerca uno stile duraturo, dalle linee morbide e delicate. Il legno è la chiave predominante della composizione, con le sue tante finiture frassinate a scelta del cliente e la particolare maniglia curva cromata, montata in modo sfalsato per creare un particolare gioco di forme nei cassetti del comò e dei comodini.

The right solution for those looking for a lasting style, with soft and delicate lines. Wood is the predominant key of the composition, with its many ash finishes chosen by the customer and the particular chrome-plated curved handle, mounted in a staggered way to create a particular play of shapes in the dresser and bedside drawers.



gola particolare scanalatura nel legno.
throat particular groove in the wood.



piedini disponibili →
available legs



PIEDINO ACCIAIO. cm. h. 17



GAMBA DRITTA ACCIAIO. cm. h. 13.



GAMBA VETRO. cm. h. 17.



PIEDINO METALLO. cm. h. 17.



BASAMENTO LEGNO. cm. h. 6.

bedroom design
contemporary



elementi singoli in frassino per camera individual ash elements for bedroom

Le camere da letto complete comprendono tutta una serie di complementi arredo zona notte che compongono un progetto di arredamento già ben definito. Una camera da letto moderna, interamente in legno massello di frassino che abbina la qualità del legno, al gusto ed alle tendenze attuali. La soluzione giusta per chi cerca uno stile duraturo, dalle linee morbide e delicate. Il legno è la chiave predominante della composizione, con le sue tante finiture frassinate a scelta del cliente e la particolare maniglia curva cromata, montata in modo sfalsato per creare un particolare gioco di forme nei cassetti del comò e dei comodini.

The complete bedrooms include a whole series of bedroom furniture complements that make up a well-defined furnishing project. Is a modern bedroom, entirely in solid ash wood that combines the quality of wood, taste and current trends. The right solution for those looking for a lasting style, with soft and delicate lines. Wood is the predominant key of the composition, with its many ash finishes chosen by the customer and the particular chrome-plated curved handle, mounted in a staggered way to create a particular play of shapes in the dresser and bedside drawers.



articolo 3215
giroletto in FRASSINO con contenitore interno
meccanismo alzata verticale e testata imbottita
(rete da 160 x 195). bed frame in ASH WOOD
with internal container with vertical lift mechanism
and upholstered headboard (bed base 160 x 195).



articolo 3216
letto matrimoniale in FRASSINO
con testata imbottita (rete da 160 x 195).
double bed in ASH WOOD with upholstered
headboard (bed base 160 x 195).
cm. l. 173 p. 210 h. 110



articolo 3217
comò in FRASSINO 3 cassetti
con guide ammortizzate e zoccolo.
chest of 3 drawers in ASH WOOD
with soft closing and basemet.
cm. l. 130 p. 55 h. 80,5



articolo 3218
comodino in FRASSINO 2 cassetti
con guide ammortizzate e zoccolo.
bedside table 2 drawers in ASH WOOD
with soft closing and basemet.
cm. l. 58 p. 40 h. 45,5



articolo 3219
comò in FRASSINO 3 cassetti
con guide ammortizzate e piedini in metallo.
chest of 3 drawers in ASH WOOD
with soft closing and metal legs.
cm. l. 130 p. 55 h. 92



articolo 3220
comodino in FRASSINO 2 cassetti
con guide ammortizzate. e piedini in metallo.
bedside table 2 drawers in ASH WOOD
with soft closing and metal legs.
cm. l. 58 p. 40 h. 57



articolo 3221
cornice rettangolare in FRASSINO
con specchio liscio. rectangular frame
in ASH WOOD with smooth mirror.
cm. l. 110 sp. 2,7 h. 60

bedroom design
contemporary



Cabina Armadio

cabina armadio
in frassino

cabina armadio
in frassino

Camera

bedroom design
contemporary



bedroom design
contemporary

Cabina Armadio

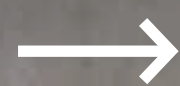

cabina armadio
in frassino





articolo **4053**
coppia supporti paletti.
pair of pole supports.



articolo **4054**
coppia supporti per cassetti.
pair of drawer supports.



articolo **4055**
coppia supporti per mensole legno.
pair of supports for wooden shelves.

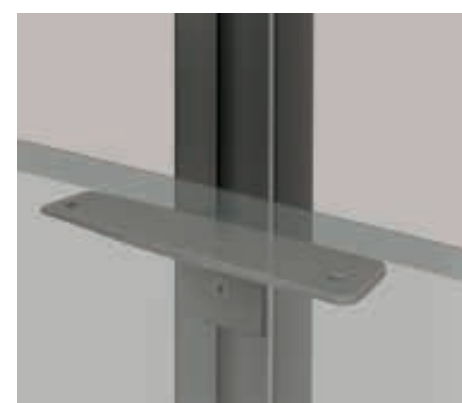

articolo **4056**
coppia supporti per mensole vetro.
pair of supports for glass shelves.



articolo **4057**
luci al led.
led lights.



articolo **4058**
palo porta abiti in alluminio.
aluminum clothes pole.



luci al led da inserire nella parte posteriore del montante. led lights to be inserted in the rear part of the upright.

sistema componibile
modular system



articolo **4051**
montante in metallo con piedino
parte finale per fissaggio a muro.
metal upright with final foot for wall
fixing. cm. h. 260

articolo **4052**
montante in metallo con piedino
parte finale per fissaggio a soffitto.
metal upright with foot final part for ceiling
fixing. cm. h. max 300

Progettiamo soluzioni d'arredo al servizio dell'ergonomia e della funzione. Librerie Modulari, realizzate con materiali innovativi ed eco-compatibili. Sospese, a parete o al centro stanza: le librerie di design donano personalità e carattere al soggiorno. Tante soluzioni di arredo su misura, allineate o disallineate, da progettare come vuoi tu, per una grande libertà di composizione. Caratteristico design minimal e contemporaneo, ideale in ogni ambiente, dalla zona giorno alla zona notte rendendo ogni locale semplicemente impeccabile. La struttura modulare permette di creare infinite combinazioni sviluppabili orizzontalmente o verticalmente per coprire qualsiasi tipo di spazio.

We design furnishing solutions at the service of ergonomics and function. Modular bookcases, made with innovative and eco-compatible materials. Suspended, on the wall or in the center of the room: designer bookcases give personality and character to the living room. Many tailor-made furnishing solutions, aligned or misaligned, to be designed as you want, for great freedom of composition. Characteristic minimal and contemporary design, ideal in any environment, from the living area to the sleeping area, making every room simply impeccable. The modular structure allows you to create infinite combinations that can be developed horizontally or vertically to cover any type of space.

montante con scanalatura sul retro per inserimento strisce a led (OPTIONAL).
upright with groove on the back for inserting LED strips (OPTIONAL)



bedroom design
contemporary

Caterina

in frassino

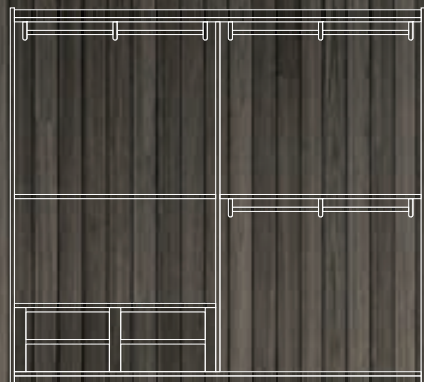

armadio disposizione interna di serie.
wardrobe internal layout as standard.



LA NOTTE



bedroom design contemporary



elementi singoli in frassino per camera
individual ash elements for bedroom

Una camera da letto moderna, interamente in legno massello di frassino che abbina la qualità del legno, al gusto ed alle tendenze attuali. La soluzione giusta per chi cerca uno stile duraturo, dalle linee morbide e delicate. Il legno è la chiave predominante della composizione, con le sue tante finiture frassinate a scelta del cliente e la particolare maniglia curva cromata, montata in modo sfalsato per creare un particolare gioco di forme nei cassetti del comò e dei comodini.

Is a modern bedroom, entirely in solid ash wood that combines the quality of wood, taste and current trends. The right solution for those looking for a lasting style, with soft and delicate lines. Wood is the predominant key of the composition, with its many ash finishes chosen by the customer and the particular chrome-plated curved handle, mounted in a staggered way to create a particular play of shapes in the dresser and bedside drawers.



articolo 3242
letto matrimoniale in FRASSINO con testata legno (rete da 160 x 195). double bed in ASH WOOD with wooden headboard (bed base 160 x 195).
cm. l. 173 p. 206 h. 110



articolo 3243
letto matrimoniale in FRASSINO con testata imbottita (rete da 160 x 195). double bed in ASH WOOD with upholstered headboard (bed base 160 x 195).
cm. l. 173 p. 206 h. 110



articolo 3240
armadio in FRASSINO 2 ante scorrevoli legno. 2 sliding wooden doors wardrobe in ASH WOOD.
cm. l. 274 p. 66 h. 248



articolo 3241
armadio in FRASSINO 2 ante scorrevoli con specchi lisci. 2 sliding doors wardrobe in ASH WOOD with smooth mirrors.
cm. l. 274 p. 66 h. 248



articolo 3244
giroletto in FRASSINO con testata legno e contenitore interno meccanismo alzata verticale (rete da 160 x 195). bed frame in ASH WOOD with wooden headboard and internal container with vertical lift mechanism (bed base 160 x 195).



articolo 3245
giroletto in FRASSINO con testata imbottita e contenitore interno meccanismo alzata verticale (rete da 160 x 195). bed frame in ASH WOOD with upholstered headboard and internal container with vertical lift mechanism (bed base 160 x 195).



articolo 3246
comò in FRASSINO 3 cassetti con guide PUSH and PULL, stabilizzatore e zoccolo. chest of 3 drawers in ASH WOOD with PUSH and PULL guides, stabilizer and basement.
cm. l. 120 p. 55 h. 77



articolo 3247
comodino in FRASSINO 3 cassetti con guide PUSH and PULL e zoccolo. bedside table 3 drawers in ASH WOOD with PUSH and PULL guides, and basement.
cm. l. 60 p. 40 h. 52



articolo 3248
cornice rettangolare in FRASSINO con specchio liscio. rectangular frame in ASH WOOD with smooth mirror.
cm. l. 110 sp. 2,7 h. 66



set stabilizzatore laterale di serie migliora la stabilità dei cassetti del comò. lateral stabilizer set as standard improves the stability of chest of drawers.

in frassino

Caterina

bedroom design
contemporary

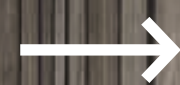

in frassino
Caterina
bedroom design
contemporary



LA NOTTE

in tangerina
con inserti frassino

Valeria

bedroom design
contemporary





articolo 3250
armadio 2 ante scorrevoli
in TANGANICA con inserti in FRASSINO.
2 sliding doors wardrobe in TANGANYIKA
WOOD with ASH WOOD inserts.
cm. l. 274 p. 66 h. 248



articolo 3251
armadio 2 ante scorrevoli in TANGANICA
con inserti in FRASSINO e specchio liscio.
2 sliding doors wardrobe in TANGANYIKA WOOD
with ASH WOOD inserts and smooth mirror.
cm. l. 274 p. 66 h. 248

in tanganica con inserti frassino
tanganyika with ash inserts

**bedroom design
contemporary**



articolo 3252
letto matrimoniale in TANGANICA
con testata imbottita (rete da 160 x 195).
double bed in TANGANYIKA with upholstered
headboard (bed base 160 x 195).
cm. l. 173 p. 210 h. 110



articolo 3253
letto matrimoniale con testata legno in TANGANICA
con inserti in FRASSINO (rete da 160 x 195).
double bed with wooden headboard in TANGANYIKA
with ASH WOOD inserts (bed base 160 x 195).
cm. l. 173 p. 210 h. 110



articolo 3254
letto matrimoniale con testata traforata in TANGANICA
con inserti in FRASSINO (rete da 160 x 195).
double bed with perforated headboard in TANGANYIKA
with ASH WOOD inserts (bed base 160 x 195).
cm. l. 173 p. 210 h. 110



articolo 3255
contenitore interno in TANGANICA con testata
imbottita alzata verticale (rete da 160 x 195).
internal container in TANGANICA with head upholstered
vertical lift mechanism (bed base 160 x 195).



articolo 3256
comò 3 cassetti in TANGANICA con inserti in FRASSINO
guide PUSH and PULL, stabilizzatore e piedini.
chest of 3 drawers in TANGANYIKA with ASH WOOD
inserts PUSH and PULL guides, stabilizer and legs.
cm. l. 130 p. 55 h. 98,5



articolo 3257
comodino 2 cassetti in TANGANICA con inserti
in FRASSINO guide ammortizzate PUSH PULL e piedini.
bedside table 2 drawers TANGANYIKA with ASH
WOOD inserts PUDH PULL guides and legs.
cm. l. 60 p. 40 h. 57,5



articolo 3258
cornice rettangolare traforata
con specchio liscio in FRASSINO.
rectangular perforated frame
in ASH WOOD with smooth mirror.
cm. l. 130 sp. 1,1 h. 74,5



articolo 3256/Z
comò 3 cassetti in TANGANICA con inserti in FRASSINO
guide PUSH and PULL, stabilizzatore e zoccolo.
chest of 3 drawers in TANGANYIKA with ASH WOOD
inserts PUSH and PULL guides, stabilizer and basement.
cm. l. 130 p. 55 h. 87



set stabilizzatore laterale di serie
migliora la stabilità dei cassetti del comò.
lateral stabilizer set as standard
improves the stability of chest of drawers.



articolo 3257/Z
comodino 2 cassetti in TANGANICA con inserti
in FRASSINO guide ammortizzate PUSH PULL e zoccolo.
bedside table 2 drawers in TANGANYIKA with ASH
WOOD inserts PUDH PULL guides and basement.
cm. l. 60 p. 40 h. 46

bedroom design
contemporary

Valeria

in tanganica
con inserti frassino

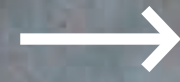

LA NOTTE

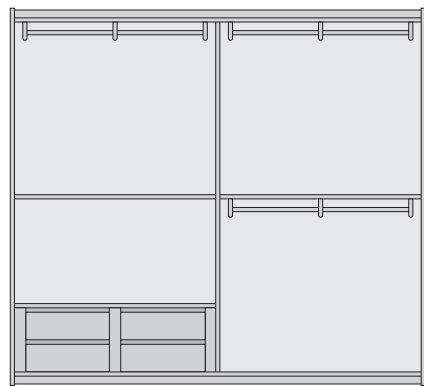

armadio disposizione interna di serie.
wardrobe internal layout as standard.

La camera da letto contemporanea nasce da un progetto unico, che veste la stanza come un abito sartoriale. Il letto e i mobili vengono disposti liberamente, per creare l'architettura che meglio risponde alle esigenze di chi li sceglie. Anche le finiture sono molteplici e consentono, insieme all'accostamento di materiali diversi, di raggiungere un alto grado di personalizzazione. L'atmosfera della camera da letto segue quindi il trend attuale della ricerca dell'essenzialità, attraverso il minimalismo delle forme, la linearità delle varie componenti. Mette inoltre in primo piano la qualità della materia prima utilizzata: il vero legno dona calore e una sobria eleganza agli spazi, confermando allo stesso tempo l'attenzione dei produttori per il green design.

The contemporary bedroom is born from a unique project, which dresses the room like a tailored suit. The bed and furniture are arranged freely, to create the architecture that best meets the needs of those who choose them. The finishes are also varied and allow, together with the combination of different materials, to achieve a high degree of customisation. The atmosphere of the bedroom therefore follows the current trend of the search for essentiality, through the minimalism of the shapes, the linearity of the various components. It also highlights the quality of the raw material used: real wood gives warmth and a sober elegance to the spaces, at the same time confirming the producers' attention to green design.

bedroom design
contemporary

Valeria

in tangerina
con inserti frassino





Ludovica

bedroom design
contemporary



LA NOTTE

bedroom design
contemporary

Ludovica

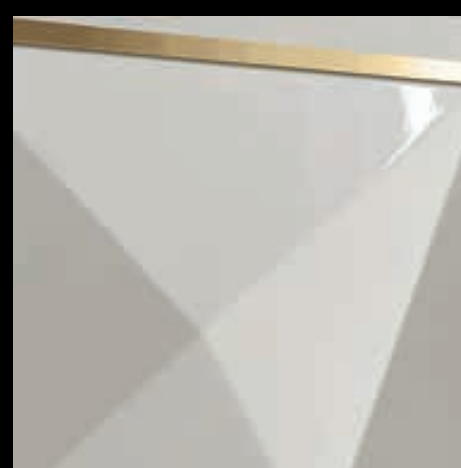
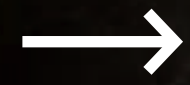



bedroom design contemporary



elementi singoli per camera individual elements for bedroom

Camera da letto completa laccato bianco lucido offre una composizione dalle linee naturali e un design senza pari, contemporaneo ed elegante per arricchire ogni spazio notte. Set concepito per creare un ambiente raffinato e accogliente, ideale per chi cerca un rifugio personale per il relax. La speciale tonalità in bianco laccato lucido, infatti, regala un'esperienza di classe e senza eguali, che dona freschezza e modernità. Questa camera da letto si caratterizza per le sue linee geometriche. In ogni elemento troviamo una fascia in metallo dorato a contrasto con il bianco lucido dei mobili. Anche gli specchi presenti sulle ante scorrevoli dell'armadio, presentano una fascia in metallo dorato. Ottima soluzione per chi ama essere originale e pensare fuori dagli schemi.

Complete glossy white lacquered bedroom offers a composition with natural lines and an unparalleled, contemporary and elegant design to enrich any sleeping space. Set designed to create a refined and welcoming environment, ideal for those looking for a personal refuge for relaxation. The special shade in glossy white lacquer, in fact, gives a classy and unparalleled experience, which gives freshness and modernity. This bedroom is characterized by its geometric lines. In each element we find a golden metal band contrasting with the shiny white of the furniture. Even the mirrors on the sliding doors of the wardrobe have a golden metal band. Excellent solution for those who love to be original and think outside the box.

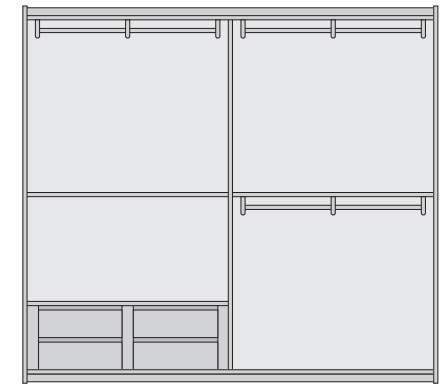

armadio disposizione interna di serie.
wardrobe internal layout as standard.



articolo **3270**
armadio 2 ante scorrevoli diamantate con profili in metallo dorato.
2 sliding diamond doors wardrobe with golden metal profiles.
cm. l. 274 p. 66 h. 248



articolo **3271**
armadio 2 ante scorrevoli diamantate con profili in metallo dorato e specchio liscio.
2 sliding diamond doors wardrobe with golden metal profiles and smooth mirror.
cm. l. 274 p. 66 h. 248



articolo **3272**
letto matrimoniale con testata diamantata con profili in metallo dorato (rete da 160 x 195).
double bed with diamond headboard with golden metal profiles (bed base 160 x 195).
cm. l. 176 p. 210 h. 150



articolo **3273**
letto matrimoniale con testata imbottita e profili in metallo dorato (rete da 160 x 195).
double bed with upholstered headboard and golden metal profiles (bed base 160 x 195).
cm. l. 176 p. 210 h. 150

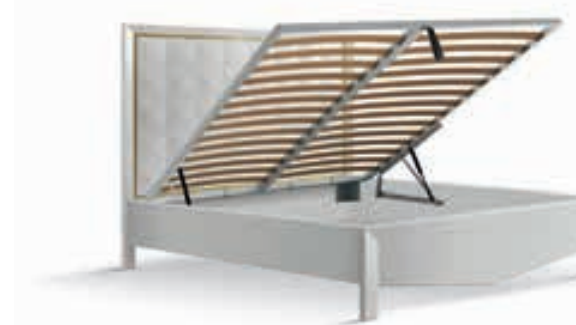

articolo **3274**
giroletto con contenitore interno meccanismo alzata verticale (rete da 160 x 195).
bed frame with internal container with vertical lift mechanism (bed base 160 x 195).



articolo **3275**
comò 3 cassetti diamantati con profili in metallo dorato e guide PUSH and PULL.
chest of 3 diamond drawers with golden metal profiles and PUSH and PULL guides.
cm. l. 136 p. 55 h. 84,5



articolo **3276**
comodino 2 cassetti diamantati con profili in metallo dorato e guide PUSH and PULL.
bedside table 2 diamond drawers with golden metal profiles and PUSH and PULL guides.
cm. l. 58 p. 40 h. 54,5



articolo **3277**
4 rettangoli specchio liscio.
4 smooth mirror rectangles.
cm. l. 106 sp. 2,7 h. 86



set stabilizzatore laterale di serie migliora la stabilità dei cassetti del comò.
lateral stabilizer set as standard improves the stability of chest of drawers.



bedroom furniture
classic design

Martina

Italiancollectionsbedroom 338



339 Italiancollectionsbedroom



Martina

bedroom furniture
classic design



articolo **3280**
armadio 2 ante scorrevoli legno.
2 sliding wooden doors wardrobe.
cm. l. 280 p. 65 h. 253

articolo **3281**
armadio 2 ante scorrevoli con specchi.
2 sliding doors wardrobe with mirrors.
cm. l. 280 p. 65 h. 253

articolo **3282**
comò 5 cassetti. chest of 5 drawers.
cm. l. 120 p. 56 h. 110

articolo **3283**
comodino 2 cassetti.
bedside table 2 drawers.
cm. l. 58 p. 40 h. 64

articolo **3284**
specchiera rettangolare.
rectangular mirror.
cm. l. 115 sp. 2,7 h. 80

articolo **3285**
letto matrimoniale con testiera traforata
(rete da 160 x 195). double bed with perforated
headboard (bed base 160 x 195).
cm. l. 196 p. 210 h. 120

articolo **3286**
letto matrimoniale con testiera traforata
e contenitore interno meccanismo alzata
verticale (rete da 160 x 195).
double bed with perforated headboard
and internal container vertical lift
mechanism (bed base 160 x 195).

articolo **3287**
letto matrimoniale con testiera imbottita.
(rete da 160 x 195). double bed with upholstered
headboard (bed base 160 x 195).
cm. l. 196 p. 210 h. 120

articolo **3288**
letto matrimoniale con testiera imbottita
e contenitore interno meccanismo alzata
verticale (rete da 160 x 195).
double bed with upholstered headboard
and internal container vertical lift
mechanism (bed base 160 x 195).





Martina

bedroom furniture
classic design

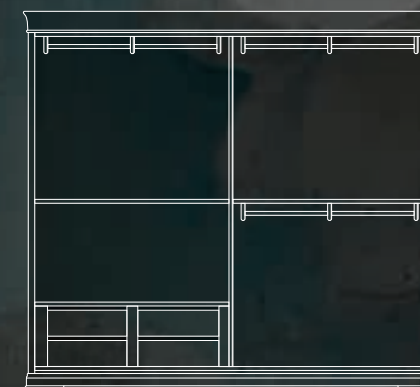
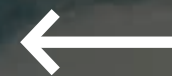

armadio disposizione interna di serie.
wardrobe internal layout as standard.



Armadio a 2 ante scorrevoli è contraddistinto da uno stile classico contemporaneo che ben s'inserisce in un contesto moderno. Armadio a 2 ante scorrevoli. Completo di cassetta interna composta da 4 cassetti e maniglie a incasso. Questo armadio ha un design tradizionale, perfetto per arredamenti classici. Il calore del legno e la cura delle lavorazioni lo rendono un mobile perfetto per una casa tradizionale ed elegante. Scegliendo colori tenui e delicati come il bianco o il crema, è possibile vivacizzare il mobile rendendolo perfetto per un arredamento attuale e contemporaneo.

Wardrobe with 2 sliding doors is characterized by a contemporary classic style that fits well into a modern context. Wardrobe with 2 sliding doors. Complete with internal chest of drawers consisting of 4 drawers and recessed handles. This wardrobe has a traditional design, perfect for classic furnishings. The warmth of the wood and the care of the workmanship make it a perfect piece of furniture for a traditional and elegant home. By choosing soft and delicate colors such as white or cream, it is possible to liven up the piece of furniture making it perfect for a current and contemporary decor.



343 Italiancollectionsbedroom

Italiancollectionsbedroom 342

bedroom design
contemporary

← Milena

articolo **2120**
armadio 2 ante scorrevoli in FRASSINO.
2 sliding doors wardrobe in ASH WOOD.
cm. l. 274 p. 65 h. 248

articolo **2121**
letto matrimoniale con testata
legno in FRASSINO (rete da 160 x 195).
double bed with wooden headboard
in ASH WOOD (bed base 160 x 195).
cm. l. 173 p. 210 h. 110

articolo **2123**
comò in FRASSINO 2 cassetti con guide
ammortizzate e basamento intrecciato.
chest in ASH WOOD 2 drawers with
soft closing and braided base.
cm. l. 146 p. 55 h. 96

articolo **2124**
comodino 2 cassetti in FRASSINO con guide
ammortizzate con basamento intrecciato.
bedside table in ASH WOOD 2 drawers
with soft closing and braided base.
cm. l. 65 p. 40 h. 60

articolo **2127**
specchiera rotonda traforata in FRASSINO.
perforated round frame in ASH WOOD.
cm. ø. 87 sp. 1,3



LA NOTTE



articolo 2122
letto matrimoniale legno in FRASSINO
con testata imbottita (rete da 160 x 195).
double bed in ASH WOOD with upholstered
headboard (bed base 160 x 195).
cm. l. 173 p. 210 h. 110

articolo 2123
comò in FRASSINO 3 cassetti con guide
ammortizzate e basamento intrecciato.
chest in ASH WOOD 3 drawers with soft
closing and braided base.
cm. l. 146 p. 55 h. 96

articolo 2124
comodino 2 cassetti in FRASSINO con guide
ammortizzate e basamento intrecciato.
bedside table in ASH WOOD 2 drawers
with soft closing and braided base.
cm. l. 65 p. 40 h. 60

articolo 2128
specchiera rettangolare in FRASSINO.
rectangular frame in ASH WOOD.
cm. l. 105 sp. 2,7 h. 70

← **Milena**
bedroom design
contemporary



articolo **2123**
 comò in FRASSINO 3 cassetti con guide
 ammortizzate e basamento intrecciato.
 chest in ASH WOOD 3 drawers with soft
 closing and braided base.
 cm. l. 146 p. 55 h. 96

articolo **2124**
 comodino 2 cassetti in FRASSINO guide
 ammortizzate e basamento intrecciato.
 bedside table in ASH WOOD 2 drawers
 with soft closing and braided base.
 cm. l. 65 p. 40 h. 60

bedroom design
 contemporary

Milena





Milena

bedroom design
contemporary



LA NOTTE

articolo **2120**
armadio 2 ante scorrevoli in FRASSINO.
2 sliding doors wardrobe in ASH WOOD.
cm. l. 274 p. 65 h. 248

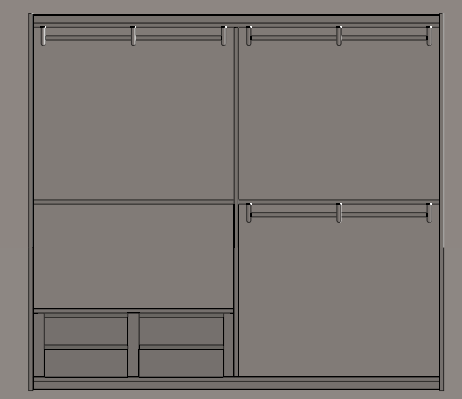

armadio disposizione interna di serie.
wardrobe internal layout as standard.



Immergiti nel fascino raffinato dell'armadio in frassino, una rara sintesi di stile ed eleganza. Il design è impreziosito da un traforo tetris che separa sapientemente le ante scorrevoli in legno, agli specchi orizzontali e verticali naturali e bruniti. L'interno, realizzato in frassino, armonizza esteticamente con l'esterno del mobile e offre una funzionalità impressionante grazie alla cassettiera, ai tre bastoni appendiabiti e ai due ripiani. La collezione Milena interpreta il concetto di modularità in una perfetta armonia tra estetica e funzionalità. L'attenta flessibilità, l'elevata personalizzazione di finiture e decori permettono di creare ambienti unici e attuali.

Immerse yourself in the refined charm of the ash wardrobe, a rare synthesis of style and elegance. The design is embellished with a tetris fretwork that expertly separates the wooden sliding doors from the natural and burnished horizontal and vertical mirrors. The interior, made of ash, aesthetically harmonizes with the exterior of the furniture and offers impressive functionality thanks to the chest of drawers, the three clothes rails and the two shelves. The Milena collection interprets the concept of modularity in a perfect harmony between aesthetics and functionality. The careful flexibility, the high customization of finishes and decorations allow you to create unique and current environments.



articolo 2119
armadio 2 ante scorrevoli in FRASSINO.
2 sliding doors wardrobe in ASH WOOD.
cm. l. 274 p. 65 h. 248

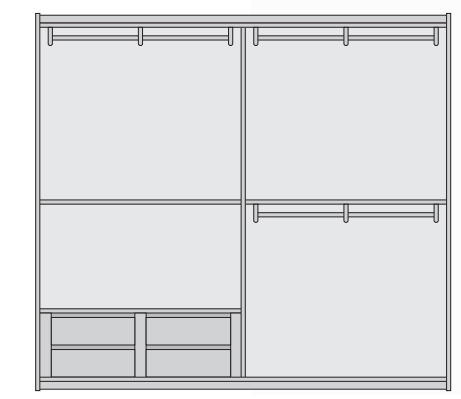

armadio disposizione interna di serie.
wardrobe internal layout as standard.

bedroom design
contemporary

Milena



← Milena

bedroom design
contemporary

articolo **2122**
letto matrimoniale legno in FRASSINO
con testata imbottita (rete da 160 x 195).
double bed in ASH WOOD with upholstered
headboard (bed base 160 x 195).
cm. l. 173 p. 210 h. 110

articolo **2123**
comò in FRASSINO 2 cassetti con guide
ammortizzate e basamento intrecciato.
chest in ASH WOOD 2 drawers with
soft closing and braided base.
cm. l. 146 p. 55 h. 96

articolo **2124**
comodino 2 cassetti in FRASSINO con guide
ammortizzate con basamento intrecciato.
bedside table in ASH WOOD 2 drawers
with soft closing and braided base.
cm. l. 65 p. 40 h. 60

articolo **2127**
specchiera rotonda traforata in FRASSINO.
perforated round frame in ASH WOOD.
cm. ø. 87 sp. 1,3



traforo tetris tetris perforated

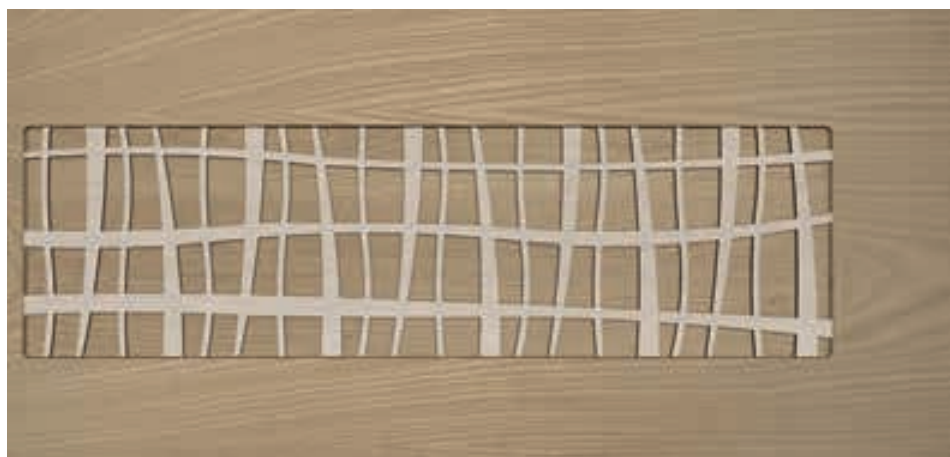

traforo natura nature perforated



traforo letter letter perforated



trafori disponibili
available perforated

articolo **2124/z**
comodino 2 cassetti in FRASSINO con guide
ammortizzate e zoccolo, bedside table in ASH
WOOD 2 drawers with soft closing and base.
cm. l. 58 p. 40 h. 50,5



articolo **2123/z**
comò in FRASSINO 3 cassetti con guide
ammortizzate e zoccolo, chest in ASH WOOD
3 drawers with soft closing and base.
cm. l. 146 p. 55 h. 86,5

I nostri designer dimostrano una sensibilità straordinaria per il dettaglio, creando complementi che aggiungono un tocco di stile e personalità alla camera da letto Giselle. La creatività dei designer si unisce alla consapevolezza dell'importanza del riposo, dando vita a soluzioni che offrono comfort senza tempo. La ricerca di prodotti sostenibili diventa sempre più presente, con l'obiettivo di creare camere da letto che siano al contempo eleganti e rispettose dell'ambiente. E non possiamo dimenticare i complementi, veri e propri protagonisti nella creazione di atmosfere uniche. Quando si tratta di abbinare colori e materiali in una camera da letto, ci sono molte considerazioni da fare. L'obiettivo principale dovrebbe essere sempre quello di creare un ambiente che rispecchi il gusto personale e che sia anche accogliente e rilassante. Questa combinazione di colori crea un'atmosfera calda e avvolgente nella camera da letto. Il colore neutro richiama il calore della terra e trasmette una sensazione di tradizione e solidità. L'abbinamento con il frassino, un legno naturale e resistente, aggiunge una nota di calore e autenticità all'ambiente.

Our designers demonstrate an extraordinary sensitivity to detail, creating accessories that add a touch of style and personality to the Giselle bedroom. The creativity of the designers combines with the awareness of the importance of rest, giving life to solutions that offer timeless comfort. The search for sustainable products is becoming increasingly present, with the aim of creating bedrooms that are both elegant and environmentally friendly. And we cannot forget the accessories, real protagonists in the creation of unique atmospheres. When it comes to matching colors and materials in a bedroom, there are many considerations to make. The main objective should always be to create an environment that reflects personal taste and is also welcoming and relaxing. This color combination creates a warm and enveloping atmosphere in the bedroom. The neutral color recalls the warmth of the earth and conveys a feeling of tradition and solidity. The combination with ash, a natural and resistant wood, adds a note of warmth and authenticity to the environment.

bedroom design
contemporary



Giselle

articolo **1031**
armadio in FRASSINO 2 ante scorrevoli
con specchi, wardrobe in ASH WOOD
2 sliding doors with mirrors.
cm. l. 274 p. 65 h. 248

articolo **1032**
comò in FRASSINO 3 cassetti con
guide amortizzate, chest in ASH WOOD
of 3 drawers with soft closing.
cm. l. 125 p. 59 h. 83

articolo **1033**
comodino in FRASSINO 2 cassetti con
guide amortizzate, bedside table in ASH
WOOD 2 drawers with soft closing.
cm. l. 61 p. 44 h. 50

articolo **1034**
letto matrimoniale imbottito
(rete da 160 x 195), upholstered
double bed (bed base 160 x 195).
cm. l. 180 p. 210 h. 115

articolo **1035**
letto matrimoniale imbottito con
contenitore interno (rete da 160 x 195).
upholstered double bed with inner
container (bed base 160 x 195).
cm. l. 180 p. 210 h. 115

articolo **1036**
specchiera sagomata in FRASSINO.
shaped frame in ASH WOOD.
cm. l. 110 sp. 1,5 h. 80

bedroom design
contemporary

Giselle

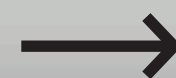



articolo **1032**
comò in FRASSINO 3 cassetti con
guide amortizzate. chest in ASH WOOD
of 3 drawers with soft closing.
cm. l. 125 p. 59 h. 83

articolo **1033**
comodino in FRASSINO 2 cassetti con
guide amortizzate. bedside table in ASH
WOOD 2 drawers with soft closing.
cm. l. 61 p. 44 h. 50



Giselle

bedroom design
contemporary



articolo **1036**
specchiera sagomata in FRASSINO.
shaped frame in ASH WOOD.
cm. l. 110 sp. 1,5 h. 80

articolo **1037**
comò in FRASSINO 3 cassetti
con guide amortizzate e piedini.
chest in ASH WOOD of 3 drawers
with soft closing and legs.
cm. l. 125 p. 59 h. 93

articolo **1038**
comodino in FRASSINO 2 cassetti
con guide amortizzate e piedini.
bedside table in ASH WOOD 2 drawers
with soft closing and legs.
cm. l. 61 p. 44 h. 60



Nel momento stesso in cui si decide di optare per una camera da letto completa, oltre a considerare l'aspetto puramente funzionale degli elementi d'arredo, è necessario scegliere tra una camera da letto moderna o una camera da letto classica. In questo modo si potrà godere di un ambiente unitario e ben studiato nella sua complessità, che non solo arreda una parte della casa ma che ben si accosta allo stile d'arredo che già si è scelto di declinare in tutti gli altri ambienti. Le soluzioni notte che Vi proponiamo sono rivolte a chi ama lo stile moderno ed elegante senza rinunciare ad un tocco personalizzato ed originale. La zona notte è un universo privato, è lo spazio abitativo più intimo della casa, dove bellezza e comfort devono coesistere. Letti, comodini, cassettiere e tutti i singoli elementi che compongono una camera da letto, devono rispecchiare il gusto personale di chi le utilizza, creando benessere.

The moment you decide to opt for a complete bedroom, in addition to considering the purely functional aspect of the furniture, you need to choose between a modern bedroom or a classic bedroom. In this way you will be able to enjoy a unified and well-studied environment in its complexity, which not only furnishes a part of the house but which is well suited to the style of furniture that has already been chosen to decline in all other environments. The night solutions that we propose are addressed to those who love the modern style and stylish without giving up a touch personalized and original. The sleeping area is a private universe, is the most intimate living space of the house, where beauty and comfort must coexist. Beds, bedside tables, chests of drawers and all the individual elements that make up a bedroom, They must reflect the personal taste of those using it, creating wealth.



articolo **1030**
armadio in FRASSINO 2 ante scorrevoli
con pannelli legno. wardrobe in ASH WOOD
2 sliding doors with wooden panels.
cm. l. 274 p. 65 h. 248

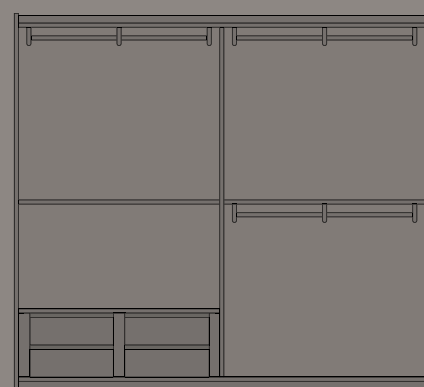

armadio disposizione interna di serie.
wardrobe internal layout as standard.

bedroom design
contemporary

Giselle



Italiancollectionsbedroom 362



363 Italiancollectionsbedroom



Clelia

bedroom design
contemporary



articolo **1076**
specchiera traforata in TANGANIKA.
perforated mirror in TANGANIKA.
cm. l. 110 h. 80

articolo **1062**
comò in TANGANIKA 3 cassetti
con intagli. chest of drawers in TANGANIKA
3 drawers with carvings.
cm. l. 127 p. 55 h. 98

articolo **1063**
comodino in TANGANIKA 2 cassetti
con intagli. bedside table in TANGANIKA
2 drawers with carvings.
cm. l. 57 p. 38 h. 56

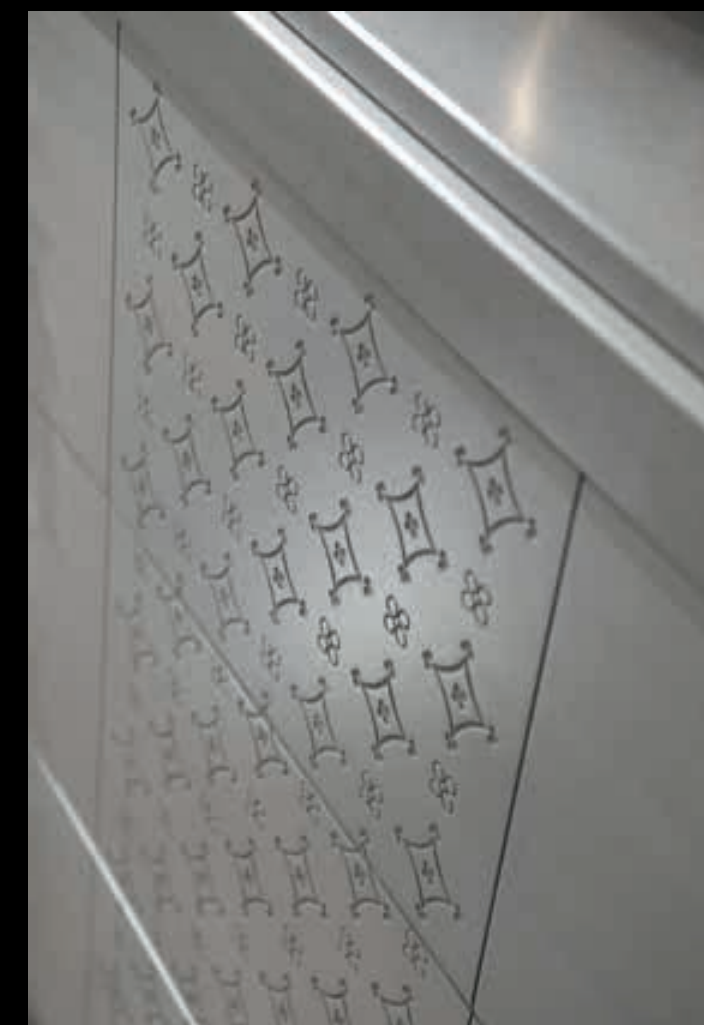

articolo **1060**
armadio in TANGANIKA 2 ante scorrevoli
con intagli. wardrobe in TANGANIKA
2 sliding doors with carvings.
cm. l. 274 p. 63 h. 249

articolo **1061**
armadio in TANGANIKA 2 ante scorrevoli
con intagli e specchi. wardrobe in TANGANIKA
sliding doors with carvings and mirrors.
cm. l. 274 p. 63 h. 249

articolo **1076**
specchiera traforata in TANGANIKA.
perforated mirror in TANGANIKA.
cm. l. 110 h. 80

articolo **1062**
comò in TANGANIKA 3 cassetti
con intagli. chest of drawers in TANGANIKA
3 drawers with carvings.
cm. l. 127 p. 55 h. 98

articolo **1063**
comodino in TANGANIKA 2 cassetti
con intagli. bedside table in TANGANIKA
2 drawers with carvings.
cm. l. 57 p. 38 h. 56

articolo **1074**
letto matrimoniale in TANGANIKA
con testiera imbottita (rete da 160 x 195).
double bed in TANGANIKA with upholstered
headboard (bed base 160 x 195).
cm. l. 172 p. 212 h. 115

← **Clelia**
bedroom design
contemporary



LA NOTTE

bedroom design
contemporary

Emma

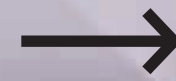

articolo **1060**
armadio in TANGANICA 2 ante scorrevoli
con intagli. wardrobe in TANGANICA
2 sliding doors with carvings.
cm. l. 274 p. 63 h. 249

articolo **1061**
armadio in TANGANICA 2 ante scorrevoli
con intagli e specchi. wardrobe in TANGANICA
2 sliding doors with carvings and mirror.
cm. l. 274 p. 63 h. 249

articolo **294**
specchiera rettangolare in TANGANICA.
TANGANICA rectangular mirror.
cm. l. 90 sp. 2,7 h. 60

articolo **1062**
comò in TANGANICA 3 cassetti
con intagli. chest of drawers in TANGANICA
3 drawers with carvings.
cm. l. 127 p. 55 h. 98

articolo **1063**
comodino in TANGANICA 2 cassetti
con intagli. bedside table in TANGANICA
2 drawers with carvings.
cm. l. 57 p. 38 h. 56

articolo **1064**
letto matrimoniale in TANGANICA
con testiera traforata (rete da 160 x 195.)
double bed in TANGANICA with perforated
headboard (bed base 160 x 195).
cm. l. 172 p. 212 h. 115



armadio disposizione interna di serie.
wardrobe internal layout as standard.



articolo **1065**
 letto matrimoniale in TANGANIKA
 con testiera traforata contenitore interno
 (rete da 160 x 195). double bed in TANGANIKA
 with perforated headboard and inner
 container (bed base 160 x 195).
 cm. l. 172 p. 212 h. 115



Le proposte di arredo dedicate alla zona notte sono studiate e progettate per garantire il massimo comfort, intimità, funzionalità senza scendere a compromessi con l'impatto estetico. Le soluzioni notte che Vi proponiamo sono rivolte a chi ama lo stile classico, moderno ed elegante senza rinunciare ad un tocco personalizzato ed originale. La zona notte è un universo privato, è lo spazio abitativo più intimo della casa, dove bellezza e comfort devono coesistere. Letti, comodini, cassettiere e tutti i singoli elementi che compongono una camera da letto, devono rispecchiare il gusto personale di chi le utilizza, creando benessere.

The proposals dedicated to the bedroom furniture are studied and designed to ensure maximum comfort, privacy, functionality without compromising the aesthetic impact. The night solutions that we propose are addressed to those who love the classic style, modern and stylish without giving up a touch personalized and original. The sleeping area is a private universe, is the most intimate living space of the house, where beauty and comfort must coexist. Beds, bedside tables, chests of drawers and all the individual elements that make up a bedroom, They must reflect the personal taste of those using it, creating wealth.



articolo **1064**
 letto matrimoniale in TANGANIKA
 con testiera traforata (rete da 160 x 195).
 double bed in TANGANIKA with perforated
 headboard (bed base 160 x 195).
 cm. l. 172 p. 212 h. 115

Emma

bedroom design
 contemporary



articolo **1066**
 letto matrimoniale in TANGANIKA
 con testiera imbottita (rete da 160 x 195).
 double bed in TANGANIKA with upholstered
 headboard (bed base 160 x 195).
 cm. l. 172 p. 212 h. 115

articolo **1067**
 letto matrimoniale in TANGANIKA
 con testiera imbottita contenitore interno
 (rete da 160 x 195). double bed in TANGANIKA
 with upholstered headboard and inner
 container (bed base 160 x 195).
 cm. l. 172 p. 212 h. 115



articolo **547/F**
specchiera rettangolare in FRASSINO.
ASH WOOD rectangular mirror.
cm. l. 115 sp. 2,7 h. 80

articolo **550/F**
armadio in FRASSINO 2 ante scorrevoli
con decoro. wardrobe in ASH WOOD
2 sliding doors with decor.
cm. l. 274 p. 65 h. 248

articolo **552/F**
comò in FRASSINO 4 cassetti
con decoro. chest in ASH WOOD
of 4 drawers with decor.
cm. l. 125 p. 55 h. 95

articolo **553/F**
comodino in FRASSINO 2 cassetti
con decoro. bedside table in ASH
WOOD 2 drawers with decor.
cm. l. 59 p. 40 h. 48

articolo **556/F**
letto in FRASSINO matrimoniale testata
legno con decoro. (rete da 160 x 195)
double bed in ASH WOOD wood headboard
with decor (bed base 160 x 195).
cm. l. 170 p. 226 h. 126

bedroom design
contemporary

← **Nicole**

in frassino

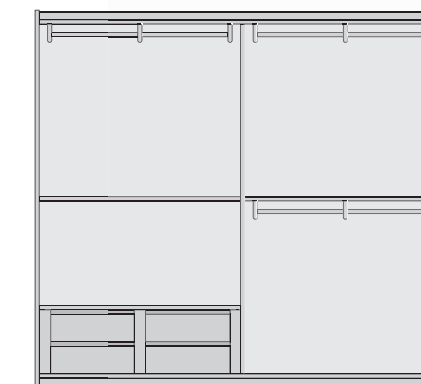

armadio disposizione interna di serie.
wardrobe internal layout as standard.

articolo 550/F
armadio in FRASSINO 2 ante
scorrevoli con decoro. wardrobe in ASH
WOOD 2 sliding doors with decor.
cm. l. 274 p. 65 h. 248

articolo 550//F
armadio in FRASSINO 2 ante scorrevoli con
decoro e specchio centrale (specchi esclusi).
wardrobe in ASH WOOD 2 sliding doors with
decor and central mirror (excluding mirrors).
cm. l. 274 p. 65 h. 248



in frassino

Nicole

bedroom design
contemporary



articolo 555/F
letto matrimoniale in FRASSINO con testata
imbottita (rete da 160 x 195).
double bed in ASH WOOD with upholstered
headboard (bed base 160 x 195).
cm. l. 170 p. 226 h. 126

articolo **554**
specchiera quadrata con decoro.
square mirror with decor.
cm. l. 70 sp. 2 h. 70

articolo **552**
comò 4 cassetti con decoro.
chest of 4 drawers with decor.
cm. l. 125 p. 55 h. 95

articolo **553**
comodino 2 cassetti con decoro.
bedside table 2 drawers with decor.
cm. l. 59 p. 40 h. 48

articolo **555**
letto matrimoniale con testata imbottita
(rete da 160 x 195). double bed with uphol-
stered headboard (bed base 160 x 195).
cm. l. 170 p. 226 h. 126



bedroom design
contemporary

Nicole



Nicole

bedroom design
contemporary



articolo **550**
armadio 2 ante scorrevoli con decoro.
wardrobe 2 sliding doors with decor.
cm. l. 274 p. 65 h. 248

articolo **558**
letto matrimoniale con testata imbottita
e contenitore interno (rete da 160 x 195).
double bed with upholstered headboard and
the inner container (bed base 160 x 195).
cm. l. 170 p. 226 h. 126



articolo **556**
letto matrimoniale con testata legno.
(rete da 160 x 195) double bed with wood
headboard (bed base 160 x 195).
cm. l. 170 p. 226 h. 126

articolo **557**
letto matrimoniale con testata legno
e contenitore interno (rete da 160 x 195).
double bed with wood headboard and the
inner container (bed base 160 x 195).
cm. l. 170 p. 226 h. 126

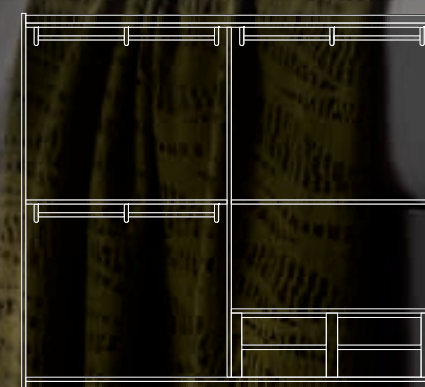

armadio disposizione interna di serie.
wardrobe internal layout as standard.



articolo **550**
 armadio 2 ante scorrevoli con decoro
 e specchio centrale (specchi esclusi).
 wardrobe 2 sliding doors with decor
 and central mirror (excluding mirrors).
 cm. l. 274 p. 65 h. 248

articolo **547**
 specchiera rettangolare liscia.
 smooth rectangular mirror.
 cm. l. 115 sp. 2,7 h. 80

articolo **548**
 comò 3 cassetti sovrapposti.
 chest of 3 stacked drawers.
 cm. l. 126+20 p. 55 h. 75

articolo **549**
 comodino 2 cassetti sovrapposti.
 bedside table 2 stacked drawers.
 cm. l. 59 p. 40 h. 48



LA NOTTE

bedroom design
 contemporary

Nicole



articolo **551**
armadio 3 ante scorrevoli con decoro
wardrobe 3 sliding doors with decor
cm. l. 317 p. 65 h. 248

articolo **551/SP.CX**
specchio per anta centrale armadio.
mirror for central wardrobe door.

articolo **551/SP**
set specchi per 3 ante armadio.
mirror set for 3 wardrobe doors.

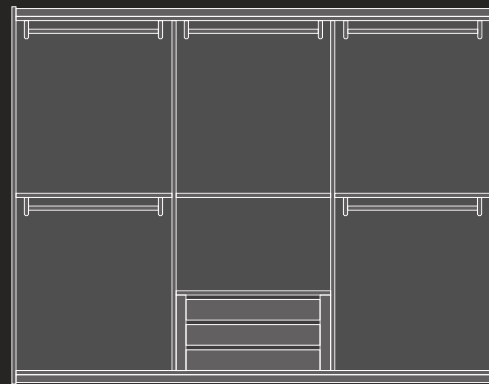

armadio disposizione interna di serie.
wardrobe internal layout as standard.



Nicole

bedroom design
contemporary

L'imponente presenza dell'armadio
è temperata dalla sobrietà delle sue linee.
the massive presence of the wardrobe
is tempered by the sobriety of its design.

Italiancollectionsbedroom 382



383 Italiancollectionsbedroom

articolo **549**
comodino 2 cassetti sovrapposti.
bedside table 2 stacked drawers.
cm. l. 59 p. 40 h. 48

articolo **556**
letto matrimoniale con testata legno.
(rete da 160 x 195). double bed with wood
headboard (bed base 160 x 195).
cm. l. 170 p. 226 h. 126

articolo **554**
specchiera quadrata con decoro.
square mirror with decor.
cm. l. 70 sp. 2 h. 70

articolo **548**
comò 3 cassetti sovrapposti.
chest of 3 stacked drawers.
cm. l. 126+20 p. 55 h. 75

bedroom design
contemporary

Vittoria →



Vittoria

bedroom design
contemporary



Italiancollectionsbedroom 386

articolo **594**
comò 4 cassetti sovrapposti.
chest of 3 stacked drawers.
cm. l. 126+20 p. 55
h. 25 x 4 (100)

articolo **595**
comò 3 cassetti sovrapposti.
chest of 3 stacked drawers.
cm. l. 126 p. 55
h. 25 x 3 (75)

misure disponibili:
available measures:



cm. 63 x 55 h. 25



cm. 90 x 55 h. 25



cm. 126 x 55 h. 25



cm. 63 x 55 h. 45



cm. 90 x 55 h. 45



cm. 126 x 55 h. 45



esempi di comò con cassetti sovrapposti

disponibili in varie misure con le quali, aggiungendo più elementi di uguali o diverse dimensioni, si possono comporre varie soluzioni per costruire il proprio comò, settimano o mobile per la zona notte.

examples chest of drawers with stacked drawers available in various sizes with which, by adding more of equal or different size elements, you can be writing various solutions to build your own chest of drawers, drawers dresser or furniture for the bedroom.

articolo **547**
specchiera rettangolare liscia.
smooth rectangular mirror.
cm. l. 115 sp. 2,7 h. 80

articolo **597**
comò 3 cassetti sovrapposti.
chest of 3 stacked drawers.
cm. l. 126+20 p. 55
h. 25 + 25 + 45 (95)

387



LA NOTTE

387 Italiancollectionsbedroom



bedroom design
contemporary

Vittoria



articolo **596**
casettiera 6 cassetti sovrapposti.
6 stacked drawers dresser.
cm. l. 55 p. 40 h. 150



articolo **598**
comò 4 cassetti sovrapposti.
chest of 4 stacked drawers.
cm. l. 126 p. 55
h. 25 x 3 (75)



linee contemporanee e particolari ricercati definiscono lo spazio notte in un equilibrato dialogo tra forme e materiali. dettagli che impreziosiscono le nuove collezioni in cui legni ed una dettagliata gamma di ecopelli disegnano il progetto the night.

contemporary lines and stylish details define the bedroom space in a well balanced dialogue between form and material. details add the wow factor to new collections, different wood and a detailed range of ecoleathers coming together to shape the night project.

Gioia

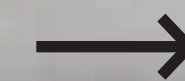

bedroom design
contemporary





Gioia

bedroom design
contemporary

articolo 717
letto matrimoniale con testata imbottita
(rete da 160 x 195), double bed with upholstered
headboard (bed base 160 x 195).
cm. l. 170 p. 226 h. 126

articolo 722
letto matrimoniale con testata imbottita
e contenitore interno (rete da 160 x 195).
double bed with upholstered headboard and
the inner container (bed base 160 x 195).
cm. l. 170 p. 226 h. 126

articolo 720
comò 4 cassetti push and pull
con intaglio, chest of 4 drawers
push and pull with carving.
cm. l. 125 p. 56 h. 108

articolo 721
comodino 2 cassetti push and pull
con intaglio, 2 drawers push and pull
bedside table with carving.
cm. l. 60 p. 39 h. 56

articolo 410
specchiera rettangolare traforata.
rectangular perforated mirror.
cm. l. 109 sp. 1,3 h. 80



articolo **729**
letto matrimoniale testata traforata
(rete da 160 x 195). double bed perforated
headboard (bed base 160 x 195).
cm. l. 170 p. 226 h. 126

articolo **724**
letto matrimoniale con testata traforata
e contenitore interno (rete da 160 x 195).
double bed with perforated headboard and
the inner container (bed base 160 x 195).
cm. l. 170 p. 226 h. 126

articolo **721**
comodino 2 cassetti push and pull
con intaglio. 2 drawers push and pull
bedside table with carving.
cm. l. 60 p. 39 h. 56



↑
bedroom design
contemporary
Gioia





Armadio con due ante scorrevoli in legno. Questo armadio è un mobile attuale, perfetto per chi cerca uno stile d'arredo moderno e raffinato. Questo armadio è realizzato con soluzioni estetiche attuali e tecniche costruttive artigianali, che garantiscono affidabilità e durata nel tempo. Sulle ante è presente una piacevole decorazione floreale in rilievo, realizzabile nello stesso colore del mobile oppure in altri colori a scelta. Questo armadio è un tipico esempio di mobile in stile classico contemporaneo. Gli arredi della zona notte sono soluzioni che si ispirano al quotidiano e interpretano con naturalezza l'unicità di ogni ambiente. Design e made in Italy ispirano la collezione di mobili per la zona bedroom, con soluzioni moderne e perfette per ogni tipo di arredamento.

Wardrobe with two sliding wooden doors. This wardrobe is a contemporary piece of furniture, perfect for those looking for a modern and refined furnishing style. This wardrobe is made with current aesthetic solutions and artisanal construction techniques, which guarantee reliability and durability over time. On the doors there is a pleasant floral decoration in relief, which can be made in the same color as the furniture or in other colors of your choice. This wardrobe is a typical example of contemporary classic style furniture. The furnishings of the sleeping area are solutions that are inspired by everyday life and naturally interpret the uniqueness of each environment. Design and made in Italy inspire the furniture collection for the bedroom area, with modern and perfect solutions for every type of furniture.

articolo **723**
armadio 2 ante scorrevoli
legno con intaglio. 2 sliding wood
doors wardrobe with carving.
cm. l. 274 p. 65 h. 248



Gioia

bedroom design
contemporary

articolo **723**
armadio 2 ante scorrevoli
con intaglio e specchi. 2 sliding doors
wardrobe with carving and mirrors.
cm. l. 274 p. 65 h. 248

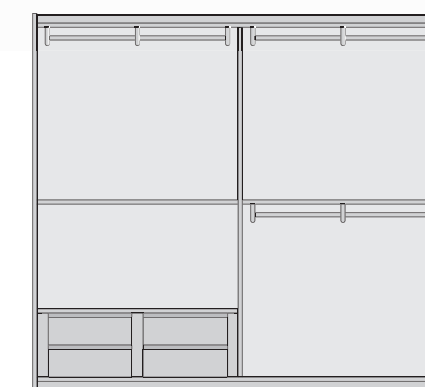

armadio disposizione interna di serie.
wardrobe internal layout as standard.

articolo **718**
letto matrimoniale testata traforata con
contenitore piede liscio (rete da 160 x 195).
double bed perforated headboard with
container smooth foot (bed base 160 x 195).
cm. l. 170 p. 226 h. 126

articolo **719**
letto matrimoniale testata
traforata piede liscio. (rete da 160 x 195).
double bed perforated headboard
smooth foot (bed base 160 x 195).
cm. l. 170 p. 226 h. 126

articolo **726**
comodino 2 cassetti push
and pull con intaglio e zoccolo.
2 drawers push and pull bedside table
with carving and baseboard.
cm. l. 59 p. 39 h. 49



articolo **725**
comò 4 cassetti push and pull
con intaglio e zoccolo. chest of 4 drawers
push and pull carving and baseboard.
cm. l. 125 p. 56 h. 95

articolo **022**
specchiera rettangolare.
rectangular mirror.
cm. l. 115 sp. 2,7 h. 80

bedroom design
contemporary

Adele



articolo **727**
letto matrimoniale con testata imbottita
e piede liscio (rete da 160 x 195).
double bed with upholstered headboard
and smooth foot (bed base 160 x 195).
cm. l. 170 p. 226 h. 126

articolo **728**
letto matrimoniale testata imbottita
con contenitore interno e piede liscio
(rete da 160 x 195). double bed upholstered
headboard and inner container with
smooth foot (bed base 160 x 195).
cm. l. 170 p. 226 h. 126



articolo **254**
letto con testata in legno
(rete da 160 x 195). bed with wooden
headboard (bed base 160 x 195).
cm. l. 185 p. 210 h. 117

articolo **250**
armadio 2 ante scorrevoli con specchi.
2-sliding doors wardrobe with mirror.
cm. l. 275 p. 65 h. 248

articolo **252**
comodino con 2 cassetti.
bedside table with 2 drawers.
cm. l. 55 p. 37 h. 53

articolo **251**
comò con 4 cassetti.
chest of drawers with 4 drawers.
cm. l. 127 p. 55 h. 96

articolo **253**
specchiera rettangolare.
rectangular mirror.
cm. l. 105 sp. 2,7 h. 70



LA NOTTE



Asia
bedroom design
contemporary



articolo **261**
comò con 4 cassetti.
chest of drawers with 4 drawers.
cm. l. 127 p. 55 h. 96

articolo **253**
specchiera rettangolare.
rectangular mirror.
cm. l. 105 sp. 2,7 h. 70

articolo **255**
letto matrimoniale con testata in legno
e contenitore interno (rete da 160 x 195).
double bed with wooden headboard
and inner container (bed base 160 x 195).
cm. l. 185 p. 210 h. 117

articolo **262**
comodino con 2 cassetti.
bedside table with 2 drawers.
cm. l. 55 p. 37 h. 53

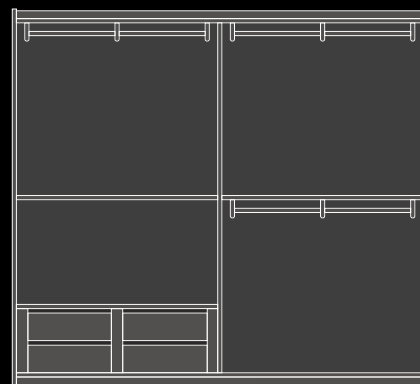

armadio disposizione interna di serie.
wardrobe internal layout as standard.

bedroom design
contemporary

Asia



articolo **250**
armadio 2 ante scorrevoli con specchi.
2-sliding doors wardrobe with mirror.
cm. l. 275 p. 65 h. 248



LA NOTTE



bedroom furniture
classic design

→ **la Notte**

Stella

bedroom furniture
classic design

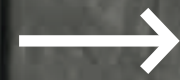

La camera da letto rappresenta un vero e proprio luogo dell'anima, l'ambiente in cui dire addio alla formalità della vita pubblica e rintanarti dedicandoti al meritato riposo. Per questa ragione la scelta dello stile è fondamentale: deve farti sentire a tuo agio e garantirti il massimo comfort possibile. Elegante, solenne, magica, quella classica è la stanza da letto ideale, in cui la tradizione rivive mantenendo un fascino indiscusso. Lo stile classico in camera da letto mescola finiture virtuose alla morbidezza delle forme, dove il ricorso alla naturalezza delle nuances si impone, rifiutando ogni eccesso. Il legno, solido e avvolgente, è il materiale cardine di questa tipologia di interior: caratterizza gli arredi grazie alle venature e imperfezioni, che conferiscono all'insieme un espediente di pregio. Lo scopo principale del classico è riuscire ad evocare un'atmosfera principesca e preziosa ma sempre attuale, grazie alla continuità tra forme ed elementi, che sembrano non invecchiare mai.

The bedroom represents a real place of the soul, the environment in which to say goodbye to the formality of public life and hole up while dedicating yourself to a well-deserved rest. For this reason, the choice of style is fundamental: it must make you feel at ease and guarantee the maximum possible comfort. Elegant, solemn, magical, the classic one is the ideal bedroom, in which tradition lives on while maintaining an undisputed charm. The classic style in the bedroom mixes virtuous finishes with the softness of the shapes, where the use of the naturalness of the nuances imposes itself, rejecting any excess. Wood, solid and enveloping, is the key material of this type of interior: it characterizes the furnishings thanks to its grain and imperfections, which give the whole a valuable element. The main purpose of the classic is to be able to evoke a princely and precious but always current atmosphere, thanks to the continuity between shapes and elements, which never seem to age.



bedroom furniture
classic design

Stella



articolo **2130**
specchiera con luce al led.
mirror with led light.
cm. l. 90 sp. 3 h. 73

articolo **2132**
comò 4 cassetti con guide ammortizzate.
chest of 4 drawers with soft closing.
cm. l. 138 p. 58 h. 110,5

articolo **2135**
letto matrimoniale con testata imbottita
e contenitore interno (rete da 160 x 195).
double bed with upholstered headboard
and inner container (bed base 160 x 195).
cm. l. 182 p. 212 h. 156

articolo **2137**
letto matrimoniale con testata imbottita
(rete da 160 x 195). double bed with
upholstered headboard (bed base 160 x 195).
cm. l. 182 p. 212 h. 156

articolo **2133**
comodino 3 cassetti con guide
ammortizzate. bedside table
3 drawers with soft closing.
cm. l. 62 p. 43 h. 69

articolo **2134**
letto matrimoniale con testata legno.
double bed with wooden headboard.
cm. l. 182 p. 212 h. 156



Stella

bedroom furniture
classic design

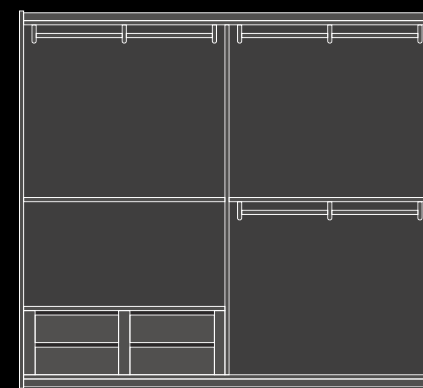

armadio disposizione interna di serie.
wardrobe internal layout as standard.

articolo **2136**
armadio 2 ante scorrevoli legno.
2 sliding wooden doors wardrobe.
cm. l. 276 p. 65 h. 247

articolo **2136/DEC**
set specchi sagomati con decoro
per armadio. set shaped mirror
with decor for wardrobe.



LA NOTTE



bedroom furniture
classic design

Viola



articolo **2144**
specchiera ovale specchio liscio
oval frame with smooth mirror.
cm. l. 90 h. 60

articolo **2140**
comò 4 cassetti con guide ammortizzate.
chest of 4 drawers with soft closing.
cm. l. 134,5 p. 62 h. 113



LA NOTTE

articolo **2140**
comò 4 cassetti con guide ammortizzate.
chest of 4 drawers with soft closing.
cm. l. 134,5 p. 62 h. 113

articolo **2144**
specchiera ovale specchio liscio
oval frame with smooth mirror.
cm. l. 90 h. 60

articolo **2145**
armadio 3 ante scorrevoli legno.
3 sliding wooden doors wardrobe.
cm. l. 289 p. 67 h. 247,5+20

articolo **2145/C**
cimasa intagliata per armadio.
carving crown for wardrobe.
cm. h. 20

articolo **2145/SP**
set specchi sagomati
per armadio. set shaped
mirror for wardrobe.

articolo **2141**
comodino 3 cassetti in con guide ammortizzate.
bedside table 3 drawers with soft closing.
cm. l. 64 p. 42,5 h. 74,5

articolo **2142**
letto matrimoniale con testata traforata
(rete da 160 x 195). double bed with
perforated headboard (bed base 160 x 195).
cm. l. 195 p. 217 h. 147

articolo **2143**
letto matrimoniale con testata traforata e
contenitore interno (rete da 160 x 195).
double bed with perforated headboard
and internal container (bed base 160 x 195).

Viola

bedroom furniture
classic design

Italiancollectionsbedroom 412



413 Italiancollectionsbedroom



bedroom furniture
classic design

Viola



armadio disposizione interna di serie.
wardrobe internal layout as standard.

Italiancollectionsbedroom 414



articolo **2145**
armadio 3 ante scorrevoli legno.
3 sliding wooden doors wardrobe.
cm. l. 289 p. 67 h. 247,5+20

articolo **2145/c**
cimasa intagliata per armadio.
carving crown for wardrobe.
cm. h. 20

articolo **2145/SP**
set specchi sagomati
per armadio, set shaped
mirror for wardrobe.



LA NOTTE

415 Italiancollectionsbedroom



Classici, rustici o vintage i letti in legno sono un must per chi ama l'eleganza. Letti in legno massello: alta qualità e design in camera da letto. Che siano in legno naturale, colorato, decapato, laccato o in legno massello i letti matrimoniali in legno hanno da sempre un grande fascino. Un letto matrimoniale in legno decapato bianco sarà perfetto per una camera romantica stile shabby chic, mentre un letto in legno scuro andrà inserito in un contesto più classico o addirittura barocco. Per uno stile moderno e contemporaneo si potrebbe scegliere un letto matrimoniale letto in pelle o ecopelle, magari colorata per dare un tocco glamour alla camera da letto.

Classic, rustic or vintage, wooden beds are a must for those who love elegance. Solid wood beds: high quality and design in the bedroom. Whether in natural, colored, pickled, lacquered or solid wood, the wooden double beds have always had a great charm. A white pickled double bed will be perfect for a shabby chic style bedroom, while a dark wood bed should be placed in a more classic or even baroque context. For a modern and contemporary style you could choose a double bed with leather or eco-leather, maybe colored to give a touch of glamor to the bedroom.

articolo 738
letto matrimoniale con testata imbottita
 (rete da 160 x 195). double bed upholstered
 headboard (bed base 160 x 195).
 cm. l. 171 p. 224 h. 140

Realbeds

bedroom furniture
 classic design



articolo 801
letto matrimoniale con testata imbottita
 (rete da 160 x 195). double bed upholstered
 headboard (bed base 160 x 195).
 cm. l. 185 p. 226 h. 148



articolo 800
letto matrimoniale con testata imbottita
 (rete da 160 x 195). double bed upholstered
 headboard (bed base 160 x 195).
 cm. l. 190 p. 212 h. 160



Italiancollectionsbedroom 416



articolo 803
letto matrimoniale con testata imbottita
 (rete da 160 x 195). double bed upholstered
 headboard (bed base 160 x 195).
 cm. l. 192 p. 211 h. 159

417 Italiancollectionsbedroom

articolo **804**
 letto matrimoniale con testata intagliata
 e contenitore interno (rete da 160 x 195).
 double bed perforated headboard and
 inner container (bed base 160 x 195).
 cm. l. 182 p. 215 h. 150



articolo **805**
 letto matrimoniale con testata intagliata
 senza contenitore interno (rete da 160 x 195).
 double bed with carved headboard without
 internal container (bed base 160 x 195).
 cm. l. 182 p. 215 h. 150



Italiancollectionsbedroom 418



La collezione di letti matrimoniali in legno è composta da una vasta gamma di modelli personalizzabili grazie all'ampia scelta delle finiture di materiali e di colore. Inoltre i letti matrimoniali sono disponibili con o senza contenitore e in varie misure per rispondere alle varie esigenze di spazio. Il legno incornicia il pregiato rivestimento in pelle, ecopelle o econabuk della testiera, mentre le cuciture mettono in risalto l'effetto imbottito. I materiali sono in armonia tra di loro e il letto è un concentrato di stile e raffinatezza. Disponibile con o senza contenitore.

The collection of wooden double beds is composed of a wide range of customizable models thanks to the wide choice of material and color finishes. Furthermore the double beds are available with or without storage and in various sizes to meet the various space requirements. Wood frames the prized leather upholstery, eco-leather or econabuk headboard, while the seams emphasize the padded effect. The materials are in harmony with each other and the bed is a concentrate of style and refinement. Available with or without container.

articolo **806**
 letto matrimoniale con testata imbottita
 (rete da 160 x 195). double bed upholstered
 headboard (bed base 160 x 195).
 cm. l. 203 p. 212 h. 175



bedroom furniture
 classic design

← **Realbeds**

419 Italiancollectionsbedroom

articolo **1000**
armadio 2 ante scorrevoli con intarsio
e specchi disegnati. 2 sliding doors with inlay
wardrobe and drawn mirrors.
cm. l. 300 p. 69 h. 251

articolo **1001**
comò 4 cassetti con intarsio, portagioie
e 2 segreti. chest of drawers with inlay,
jewelry box and 2 secrets.
cm. l. 134,5 p. 57,5 h. 116

articolo **1002**
comodino 2 cassetti con intarsio.
bedside table 2 drawers with inlay.
cm. l. 62,5 p. 42,5 h. 66,5

articolo **1003**
letto matrimoniale con testiera traforata
(rete da 160 x 195). double bed perforated
headboard (bed base 160 x 195).
cm. l. 176 p. 211 h. 121,5

articolo **1009**
specchiera rettangolare. rectangular mirror.
cm. l. 109,5 sp. 4,5 h. 89



armadio disposizione interna di serie.
wardrobe internal layout as standard.

← **Charlotte**
bedroom furniture
classic design



LA NOTTE

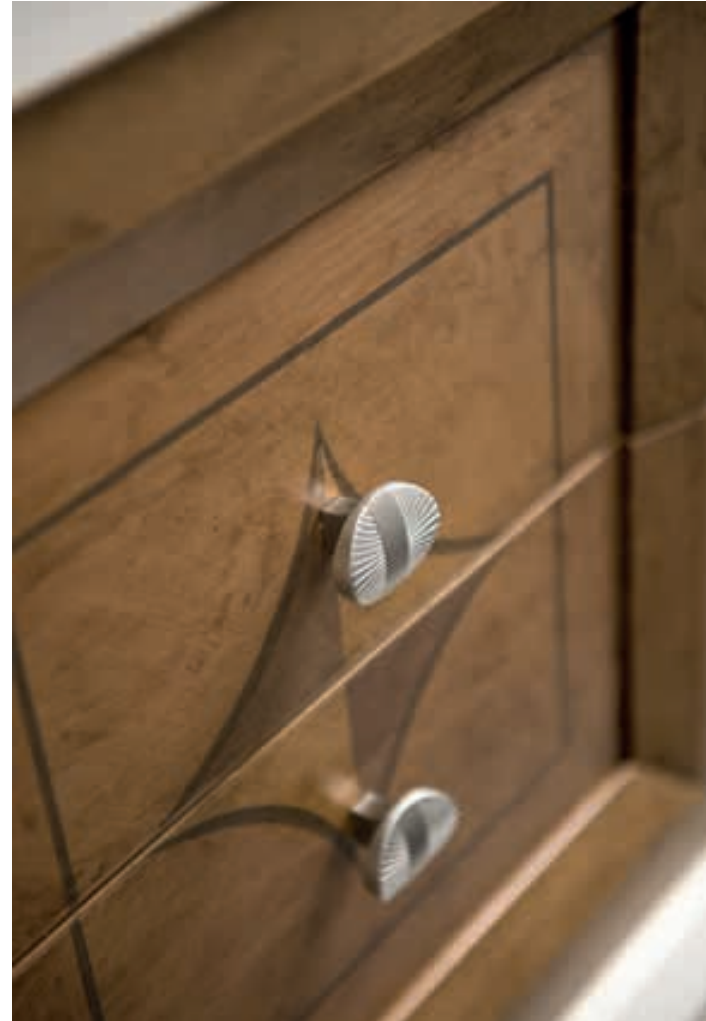

articolo 1000
armadio 2 ante scorrevoli con intarsio
e specchi disegnati. 2 sliding doors with inlay
wardrobe and drawn mirrors.
cm. l. 300 p. 69 h. 251

articolo 1001
comò 4 cassetti con intarsio, portagioie
e 2 segreti. chest of drawers with inlay,
jewelry box and 2 secrets.
cm. l. 134,5 p. 57,5 h. 116

articolo 1002
comodino 2 cassetti con intarsio.
bedside table 2 drawers with inlay.
cm. l. 62,5 p. 42,5 h. 66,5

articolo 1003
letto matrimoniale con testiera traforata
(rete da 160 x 195). double bed perforated
headboard (bed base 160 x 195).
cm. l. 176 p. 211 h. 121,5

articolo 1009
specchiera rettangolare. rectangular mirror.
cm. l. 109,5 sp. 4,5 h. 89

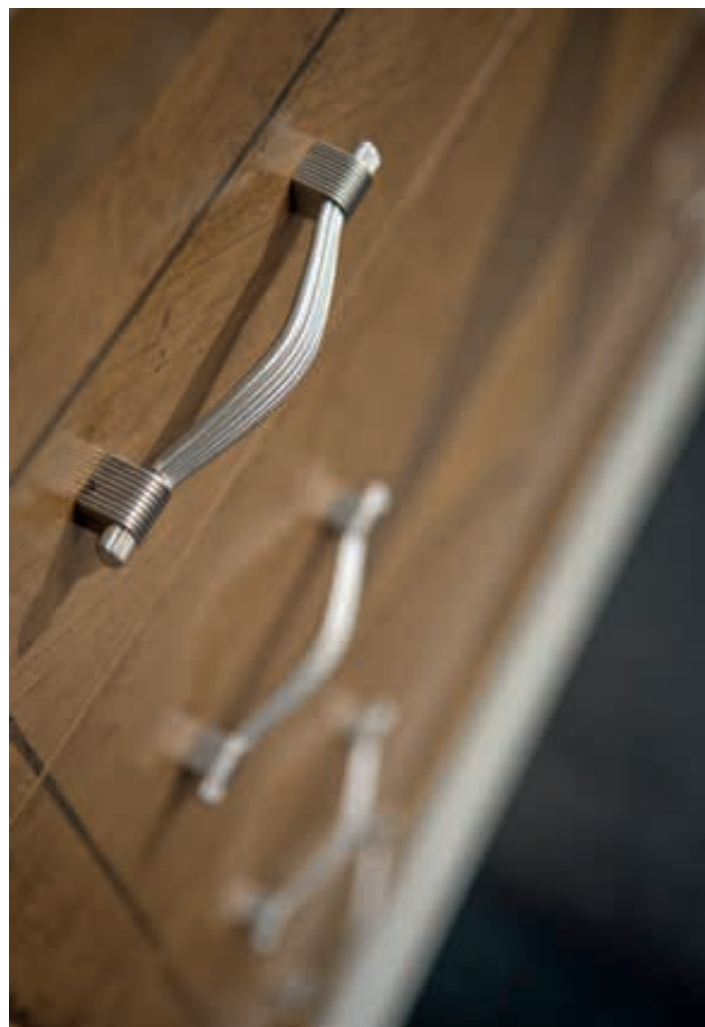

articolo 1006
letto matrimoniale con testiera traforata
e contenitore interno (rete da 160 x 195).
double bed with perforated headboard
and inner container (bed base 160 x 195).
cm. l. 176 p. 211 h. 121,5



articolo 1007
letto matrimoniale con testiera imbottita
e contenitore interno (rete da 160 x 195).
double bed with upholstered headboard
and inner container (bed base 160 x 195).
cm. l. 176 p. 211 h. 121,5



bedroom furniture
classic design

Charlotte



articolo 1005
letto matrimoniale con testiera imbottita
(rete da 160 x 195). double bed upholstered
headboard (bed base 160 x 195).
cm. l. 176 p. 211 h. 121,5

articolo **733**
armadio 2 ante scorrevoli.
2-sliding doors wardrobe.
cm. l. 273 p. 69 h. 258,5

articolo **730**
comò con 4 cassetti.
chest of drawers with 4 drawers.
cm. l. 128 p. 56 h. 116

articolo **734**
specchiera rettangolare traforata.
perforated rectangular mirror.
cm. l. 110 sp. 1,3 h. 74,5

articolo **732**
letto matrimoniale con testata e pediera
traforate (rete da 160 x 195).
double bed with headboard and footboard
perforated (bed base 160 x 195).
cm. l. 180 p. 216 h. 120

articolo **731**
comodino con 3 cassetti.
bedside table with 3 drawers.
cm. l. 63 p. 44 h. 73

bedroom furniture
classic design



Anna

LA NOTTE

articolo **222**
specchiera rettangolare traforata.
perforated rectangular mirror.
cm. l. 115 sp. 1,1 h. 86

articolo **661**
comò 4 cassetti con rilievo.
chest of 4 drawers with relief.
cm. l. 127 p. 59 h. 110

bedroom furniture
classic design

Giorgia

Italiancollectionsbedroom 426

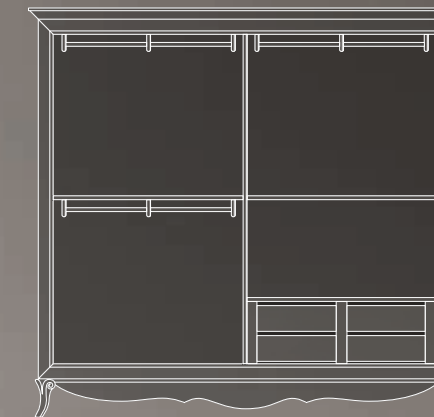

armadio disposizione interna di serie.
wardrobe internal layout as standard.

articolo **221**
armadio 2 ante scorrevoli con rilievo e specchi.
2 sliding doors wardrobe with relief and mirror.
cm. l. 281 p. 63 h. 253

articolo **665**
letto matrimoniale con testata imbottita
(rete da 160 x 195). double bed upholstered
headboard (bed base 160 x 195).
cm. l. 186 p. 205 h. 138

articolo **666**
letto matrimoniale con testata imbottita e
contenitore interno (rete da 160 x 195).
double bed upholstered headboard and
inner container (bed base 160 x 195).
cm. l. 186 p. 205 h. 138

articolo **662**
comodino 2 cassetti con rilievo.
bedside table 2 drawers with relief.
cm. l. 56 p. 40 h. 64

Silvia

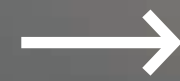

bedroom furniture
classic design



articolo **661**
comò 4 cassetti con rilievo.
chest of 4 drawers with relief.
cm. l. 127 p. 59 h. 110

articolo **222**
specchiera rettangolare traforata.
perforated rectangular mirror.
cm. l. 115 sp. 1,1 h. 86

articolo **662**
comodino 2 cassetti con rilievo.
bedside table 2 drawers with relief.
cm. l. 56 p. 40 h. 64



articolo **665**
letto matrimoniale con testata imbottita
(rete da 160 x 195). double bed upholstered
headboard (bed base 160 x 195).
cm. l. 186 p. 205 h. 138

articolo **666**
letto matrimoniale con testata imbottita e contenitore
interno (rete da 160 x 195). double bed with upholstered
headboard and inner container (bed base 160 x 195).
cm. l. 186 p. 205 h. 138

articolo **220**
armadio 2 ante scorrevoli con rilievo.
2 sliding doors wardrobe with relief.
cm. l. 281 p. 63 h. 253

bedroom furniture
classic design

Silvia



articolo **662**
comodino 2 cassetti con rilievo.
bedside table 2 drawers with relief.
cm. l. 56 p. 40 h. 64



articolo **667**
letto matrimoniale testata imbottita
con swarovski e contenitore interno
(rete da 160 x 195). double bed upholstered
headboard with swarovski and inner
container (bed base 160 x 195).
cm. l. 186 p. 205 h. 138



Italiancollectionsbedroom 430

Bedroom design
classic furniture

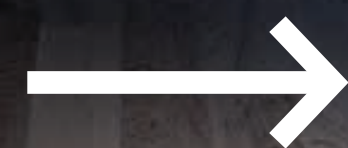

la Notte

431 Italiancollectionsbedroom

LA NOTTE

articolo **1054**
comodino sagomato intarsiato con 3 cassetti.
3 drawers shaped bedside table with inlay.
cm. l. 53 p. 40 h. 70

articolo **1055**
letto matrimoniale con testata imbottita
(rete da 160 x 195). double bed headboard
upholstered (bed base 160 x 195).
cm. l. 184 p. 210 h. 120

articolo **1048**
armadio 2 ante scorrevoli tutto specchi.
wardrobe with 2 sliding doors all mirrors.
cm. l. 275 p. 66 h. 248

articolo **1051**
armadio 2 ante scorrevoli legno.
2 sliding wooden doors wardrobe.
cm. l. 275 p. 66 h. 248

articolo **1052**
armadio 2 ante scorrevoli con specchi
lisci solo superiori. 2 sliding doors wardrobe
with smooth mirrors only at the top.
cm. l. 275 p. 66 h. 248

articolo **1057**
specchiera rettangolare traforata.
rectangular perforated mirror.
cm. l. 103 sp. 1,6 h. 73

articolo **1053**
comò sagomato intarsiato 4 cassetti.
4 drawers shaped inlay chest of drawers.
cm. l. 125 p. 57 h. 111

Sole →
bedroom furniture
classic design



articolo 1058
letto matrimoniale con testata traforata e contenitore interno (rete da 160 x 195).
 double bed with perforated headboard and inner container (bed base 160 x 195).
cm. l. 184 p. 210 h. 120

articolo 1056
letto matrimoniale con testata imbottita contenitore interno (rete da 160 x 195).
 double bed with with headboard upholstered and inner container (bed base 160 x 195).
cm. l. 184 p. 210 h. 120



articolo 1059
letto matrimoniale con testata traforata (rete da 160 x 195).
 double bed perforated headboard (bed base 160 x 195).
cm. l. 184 p. 210 h. 120



Un mood particolare che si traduce in un design emozionale: mobili in cui la componente naturale del legno è tangibile, arredi che raccontano il loro passato e sono pronti a vivere un nuovo futuro, pezzi unici, capaci di comunicare emozioni, in qualsiasi contesto si collocino, dall'abitazione in riva al mare alla più elegante residenza cittadina.

A peculiar mood that translates into an emotional design: furniture in which the natural component of wood is tangible, furnishings that tell their past and are ready to live a new future, unique pieces, able to communicate emotions, in any context they sit, From the seafront residence to the most elegant townhouse.



Italiancollectionsbedroom 434



**bedroom furniture
 classic design**



Sole



articolo 1054
comodino sagomato intarsiato con 3 cassetti.
 3 drawers shaped bedside table with inlay.
cm. l. 53 p. 40 h. 70

articolo 1053
comò sagomato intarsiato 4 cassetti.
 4 drawers shaped inlay chest of drawers.
cm. l. 125 p. 57 h. 111



435 Italiancollectionsbedroom

Sole



bedroom furniture
classic design



articolo **1052**
armadio 2 ante scorrevoli con specchi
lisci solo superiori. 2 sliding doors wardrobe
with smooth mirrors only at the top.
cm. l. 275 p. 66 h. 248

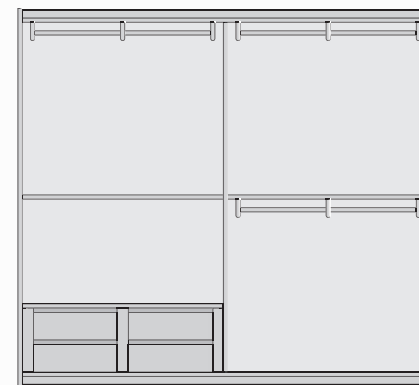

armadio disposizione interna di serie.
wardrobe internal layout as standard.

articolo **1051**
armadio 2 ante scorrevoli legno.
2 sliding wooden doors wardrobe.
cm. l. 275 p. 66 h. 248



LA NOTTE

bedroom furniture
classic design

Camera



articolo **032**
comodino con 2 cassetti.
bedside table with 2 drawers.
cm. l. 58 p. 40 h. 58

articolo **035**
letto matrimoniale con testata imbottita
(rete da 160 x 195). double bed upholstered
headboard (bed base 160 x 195).
cm. l. 183 p. 209 h. 114,5

articolo **031**
comò con 4 cassetti.
chest of drawers with 4 drawers.
cm. l. 132 p. 56 h. 99

articolo **033**
specchiera sagomata piccola.
small shaped mirror.
cm. l. 108 sp. 2,7 h. 79

articolo **030**
armadio 2 ante scorrevoli con traforo.
2 sliding perforated doors wardrobe.
cm. l. 284,5 p. 63 h. 255



Camera

bedroom furniture
classic design



articolo **032**
comodino con 2 cassetti.
bedside table with 2 drawers.
cm. l. 58 p. 40 h. 58

articolo **037**
letto matrimoniale con testata traforata
(rete da 160 x 195). double bed perforated
headboard (bed base 160 x 195).
cm. l. 170 p. 226 h. 126

articolo **037/1**
letto matrimoniale con testata imbottita
(rete da 160 x 195). double bed upholstered
headboard (bed base 160 x 195).
cm. l. 170 p. 226 h. 126

armadio disposizione interna di serie.
wardrobe internal layout as standard.

articolo **030**
armadio 2 ante scorrevoli con traforo.
Wardrobe 2 sliding perforated doors.
cm. l. 284,5 p. 63 h. 255

articolo **031**
comò con 4 cassetti.
chest of drawers with 2 drawers.
cm. l. 132 p. 56 h. 99

articolo **039**
specchiera rettangolare.
rectangular mirror.
cm. l. 110 sp. 4 h. 80

bedroom furniture
classic design

Camera



articolo **020**
comò con 4 cassetti.
chest of drawers with 4 drawers.
cm. l. 127 p. 57 h. 111

articolo **021**
comodino con 3 cassetti.
bedside table with 3 drawers.
cm. l. 62,5 p. 42 h. 76

articolo **022**
specchiera rettangolare per comò.
rectangular mirror for chest.
cm. l. 115 sp. 2,7 h. 80

articolo **023/1**
armadio con 4 ante battenti
e vetri serigrafati. 4 hinged doors
wardrobe and screenprinted glass.
cm. l. 286 p. 66 h. 252

articolo **024**
letto matrimoniale con testata
traforo moderno (rete da 160 x 195).
double bed with modern perforated
headboard (bed base 160 x 195).
cm. l. 183 p. 210 h. 117

articolo **023**
armadio con 4 ante battenti
e pannello intagliato. 4 hinged doors
wardrobe and carved panel.
cm. l. 286 p. 66 h. 252



Camera

bedroom furniture
classic design

articolo **023/2**
armadio con 4 ante battenti
e pannello liscio. 4 hinged doors
wardrobe and smooth panel.
cm. l. 286 p. 66 h. 252

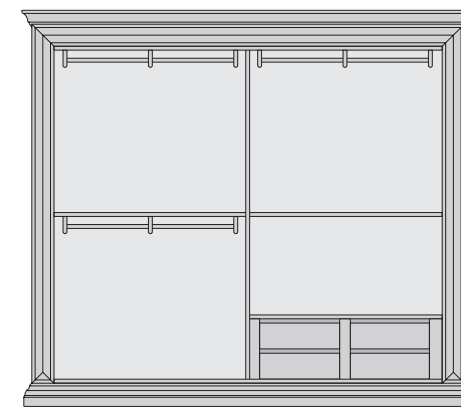

armadio disposizione interna di serie.
wardrobe internal layout as standard.

articolo **023/1**
armadio con 4 ante battenti e vetri
serigrafati. 4 hinged doors wardrobe
and screenprinted glass.
cm. l. 286 p. 66 h. 252





Camera

bedroom furniture
classic design



articolo **022**
specchiera rettangolare in legno.
rectangular wooden mirror.
cm. l. 115 p. 2,7 h. 80



articolo **020**
comò con 4 cassetti.
chest of drawer with 4 drawers.
cm. l. 127 p. 57,5 h. 111

articolo **023/1**
armadio 4 ante battenti con vetri.
4 hinged doors wardrobe with glass.
cm. l. 286 p. 66 h. 252



articolo **024/3**
letto matrimoniale con testata imbottita
(rete da 160 x 195). double bed upholstered
headboard (bed base 160 x 195).
cm. l. 183 p. 210 h. 117

articolo **021**
comodino con 3 cassetti.
bedside table with 3 drawers.
cm. l. 62,5 p. 43,5 h. 76

LA NOTTE

articolo **024**
 letto matrimoniale con testata traforo moderno
 (rete da 160 x 195). double bed with modern
 perforated headboard (bed base 160 x 195).
 cm. l. 183 p. 210 h. 117



articolo **024/1**
 letto matrimoniale con testata legno liscio
 (rete da 160 x 195). double bed with smooth
 wooden headboard (bed base 160 x 195).
 cm. l. 183 p. 210 h. 117



articolo **024/2**
 letto matrimoniale con testata intagliata a mano
 (rete da 160 x 195). double bed with with hand
 carved headboard (bed base 160 x 195).
 cm. l. 183 p. 210 h. 117



articolo **024/3**
 letto matrimoniale testata imbottita.
 (rete da 160 x 195). double bed upholstered
 headboard (bed base 160 x 195).
 cm. l. 183 p. 210 h. 117

bedroom furniture
 classic design

← Camera



LA NOTTE



articolo **025**
armadio 2 ante scorrevoli.
2 sliding doors wardrobe.
cm. l. 286 p. 66 h. 252

Camera

bedroom furniture
classic design



articolo **025/1**
armadio 2 ante scorrevoli senza traforo.
2 sliding doors no perforated wardrobe.
cm. l. 286 p. 66 h. 252



articolo **025**
armadio 2 ante scorrevoli con vetro.
2 sliding doors wardrobe with mirror.
cm. l. 286 p. 66 h. 252

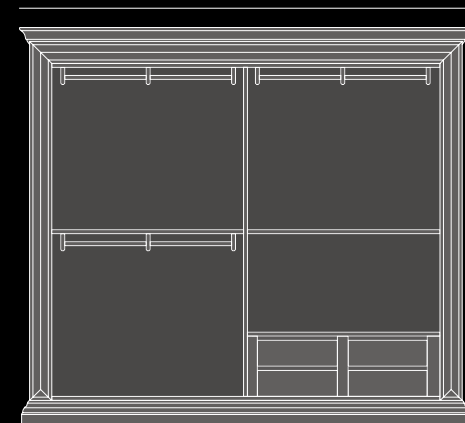

armadio disposizione interna di serie.
wardrobe internal layout as standard.



LA NOTTE

bedroom furniture
classic design

Aurora

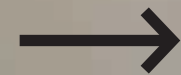

articolo **294**
specchiera rettangolare.
rectangular mirror.
cm. l. 90 h. 60

Italiancollectionsbedroom 452

articolo **291**
comò con 4 cassetti.
chest of drawers with 4 drawers.
cm. l. 128 p. 55 h. 95

articolo **293**
letto matrimoniale con testata traforata
(rete da 160 x 195). double bed perforated
headboard (bed base 160 x 195).
cm. l. 184 p. 210 h. 120

articolo **292**
comodino con 2 cassetti.
bedside table with 2 drawers.
cm. l. 63,5 p. 39 h. 54

453 Italiancollectionsbedroom



articolo **290**
armadio 2 ante scorrevoli con specchi.
2 sliding doors wardrobe with mirror.
cm. l. 276 p. 62 h. 248

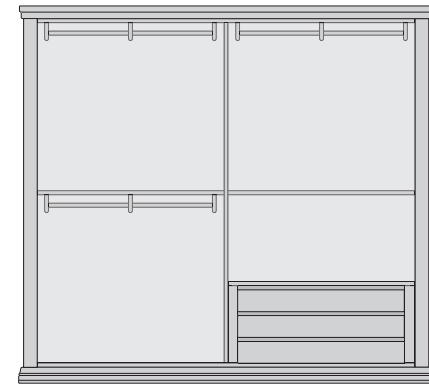

armadio disposizione interna di serie.
wardrobe internal layout as standard.



LA NOTTE

Aurora →

bedroom furniture
classic design

articolo **295**
letto matrimoniale con testata imbottita
(rete da 160 x 195). double bed upholstered
headboard (bed base 160 x 195).
cm. l. 184 p. 210 h. 120



Delia

bedroom furniture
classic design

articolo **2173**
letto matrimoniale con testata traforata
(rete da 160 x 195). double bed perforated
headboard (bed base 160 x 195).
cm. l. 184 p. 210 h. 120

articolo **2171**
comò con 4 cassetti con traforo.
chest of 4 drawers with perforated.
cm. l. 128 p. 55 h. 95

articolo **2172DX**
comodino con 2 cassetti con traforo DX.
2 drawers bedside table with DX perforated.
cm. l. 63,5 p. 39 h. 54

articolo **2172SX**
comodino con 2 cassetti con traforo SX.
2 drawers bedside table with SX perforated.
cm. l. 63,5 p. 39 h. 54

articolo **2174**
specchiera rettangolare per comò.
rectangular mirror for chest.
cm. l. 90 h. 60



articolo **2171**
comò con 4 cassetti con traforo.
chest of 4 drawers with perforated.
cm. l. 128 p. 55 h. 95



articolo **2172DX**
comodino con 2 cassetti con traforo DX.
2 drawers bedside table with DX perforated.
cm. l. 63,5 p. 39 h. 54

articolo **2172SX**
comodino con 2 cassetti con traforo SX.
2 drawers bedside table with SX perforated.
cm. l. 63,5 p. 39 h. 54

bedroom furniture
classic design

Delia



articolo **2170**
armadio 2 ante scorrevoli con specchi.
2 sliding doors wardrobe with mirrors.
cm. l. 276 p. 62 h. 248



LA NOTTE

articolo **223**
comò 4 cassetti con segreto e intaglio.
chest of 4 drawers with secret and carving.
cm. l. 127 p. 58 h. 109

articolo **894**
specchiera rettangolare per comò.
rectangular mirror for chest.
cm. l. 90 sp. 2,7 h. 60

Paola

bedroom furniture
classic design

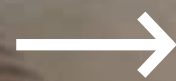

Italiancollectionsbedroom 460

articolo **227**
armadio 2 ante scorrevoli con intaglio.
2 sliding doors wardrobe with carving.
cm. l. 274 p. 88 h. 246

articolo **225**
letto matrimoniale traforato (rete da 160 x 195).
perforated double bed (bed base 160 x 195).
cm. l. 184 p. 208 h. 115

articolo **224**
comodino 2 cassetti con segreto e intaglio.
bedside table 2 drawers with secret and carving.
cm. l. 63 p. 44 h. 70

461 Italiancollectionsbedroom



bedroom furniture
classic design

Valentina

articolo **226**
armadio 2 ante scorrevoli con intaglio
e specchi centrali. 2 sliding doors wardrobe
with carving and central mirrors.
cm. l. 274 p. 68 h. 246

articolo **224**
comodino 2 cassetti con segreto e intaglio.
bedside table 2 drawers with secret and carving.
cm. l. 63 p. 44 h. 70

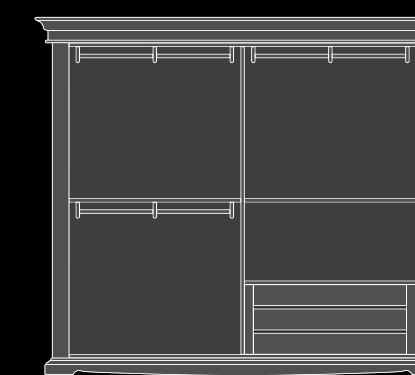

armadio disposizione interna di serie.
wardrobe internal layout as standard.

Valentina

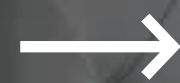

bedroom furniture
classic design

Italiancollectionsbedroom 464

articolo **228**
letto matrimoniale con testata imbottita
e pediera traforata (rete da 160 x 195).
double bed with upholstered headboard and
footboard perforated (bed base 160 x 195).
cm. l. 184 p. 208 h. 115

articolo **224**
comodino 2 cassetti con segreto e intaglio.
bedside table 2 drawers with secret and carving.
cm. l. 63 p. 44 h. 70

articolo **223**
comò 4 cassetti con segreto e intaglio.
chest of 4 drawers with secret and carving.
cm. l. 127 p. 58 h. 109

articolo **894**
specchiera rettangolare per comò.
rectangular mirror for chest.
cm. l. 90 sp. 2,7 h. 60

465 Italiancollectionsbedroom



articolo **896**
comodino con 3 cassetti con intaglio.
3 drawers bedside table with carving.
cm. l. 60 p. 42 h. 70

articolo **894**
specchiera rettangolare in legno.
rectangular wooden mirror.
cm. l. 90 sp. 2,7 h. 60

articolo **895**
comò 6 cassetti con intaglio.
6 drawers chest flap door with carving.
cm. l. 124 p. 56 h. 110

articolo **898**
letto matrimoniale testata traforata
(rete da 160 x 195). double bed perforated
headboard (bed base 160 x 195).
cm. l. 172 p. 230 h. 117

articolo **899**
letto matrimoniale testata imbottita
(rete da 160 x 195). double bed upholstered
headboard (bed base 160 x 195).
cm. l. 172 p. 230 h. 117

articolo **890**
armadio 2 ante scorrevoli con pannelli.
2 sliding doors wardrobe with panels.
cm. l. 270 p. 65 h. 248

bedroom furniture
classic design

Camera →



articolo **890**
armadio 2 ante scorrevoli con pannelli.
2 sliding doors wardrobe with panels.
cm. l. 270 p. 65 h. 248



Armadio

bedroom furniture
classic design



LA NOTTE



articolo **890**
armadio 2 ante scorrevoli con pannelli.
2 sliding doors wardrobe with panels.
cm. l. 270 p. 65 h. 248

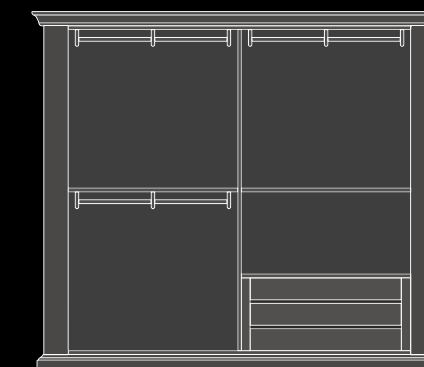

armadio disposizione interna di serie.
wardrobe internal layout as standard.

bedroom furniture
classic design

Project Armadio



bedroom furniture
classic design

Project Armadio

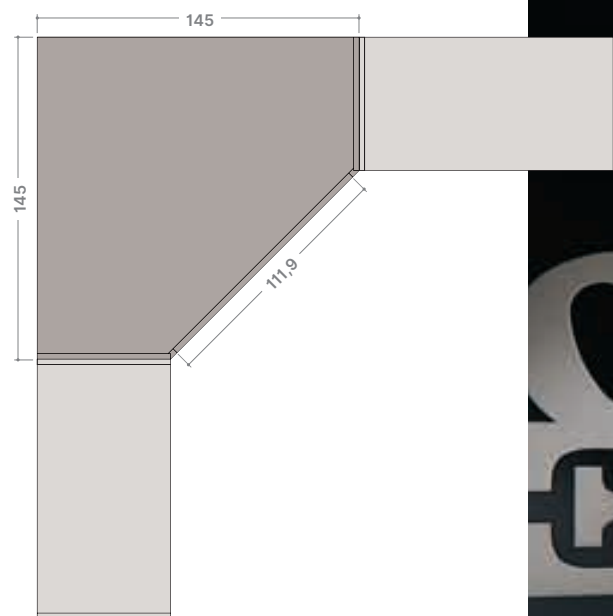

articolo **123**
angolo a 45° in TANGANIKA 2 ante
battenti DX o SX con angolo attrezzato.
TANGANIKA 45° corner 2 DX or SX
hinged doors equipped corner.
cm. h. 256

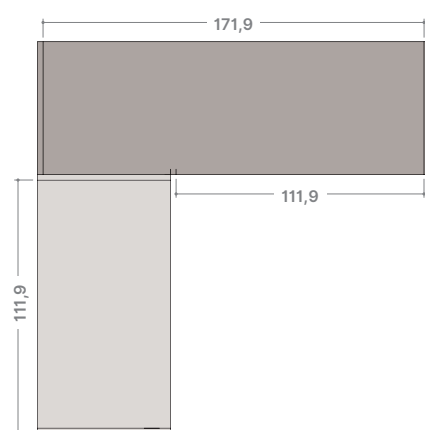

articolo **121**
angolo da 90° in TANGANIKA 2 ante
battenti DX o SX con angolo attrezzato.
TANGANIKA 90° corner 2 DX or SX
hinged doors equipped corner.
cm. h. 256



Project armadio

bedroom furniture
classic design

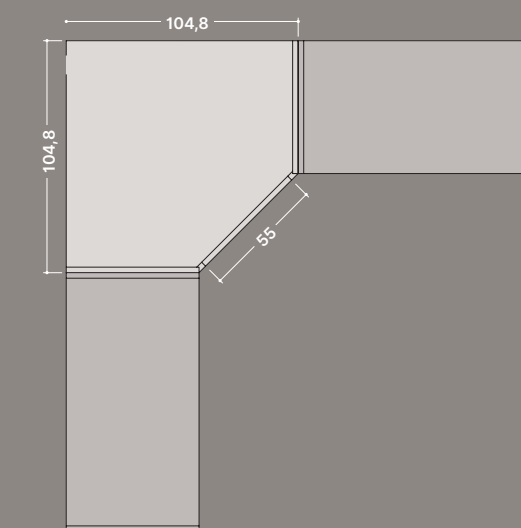

articolo 122
angolo a 45° in TANGANIKA
1 anta battente DX o SX. TANGANIKA 45°
corner 1 DX or SX hinged door.
cm. h. 256

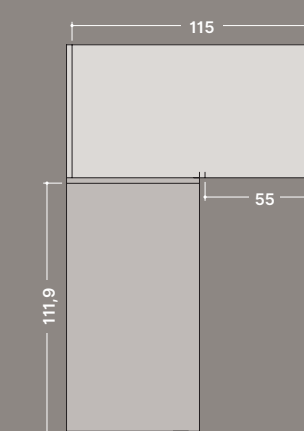

articolo 120
angolo a 90° in TANGANIKA 1 anta
battente DX o SX. TANGANIKA 90° corner
1 DX or SX hinged door.
cm. h. 256 p. 65

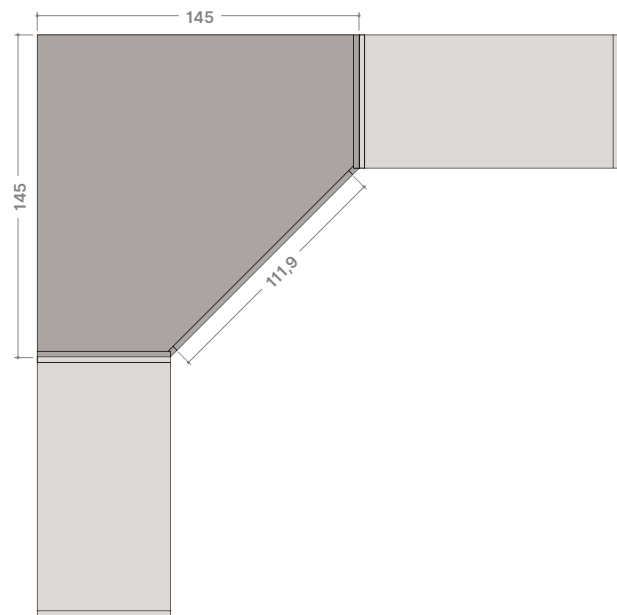

articolo **123**
 angolo a 45° in TANGANIKA 2 ante
 battenti DX o SX con angolo attrezzato.
 TANGANIKA 45° corner 2 DX or SX
 hinged doors equipped corner.
 cm. h. 256

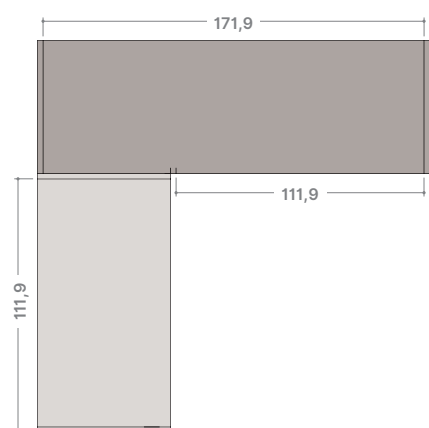

articolo **121**
 angolo da 90° in TANGANIKA 2 ante
 battenti DX o SX con angolo attrezzato.
 TANGANIKA 90° corner 2 DX or SX
 hinged doors equipped corner.
 cm. h. 256

bedroom furniture
 classic design

Project Armadio





Project armadio

bedroom furniture
classic design

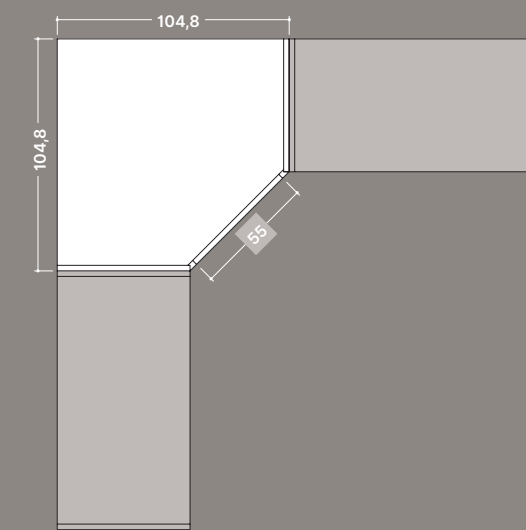

articolo **122**
angolo a 45° in TANGANIKA
1 anta battente DX o SX. TANGANIKA 45°
corner 1 DX or SX hinged door.
cm. h. 256

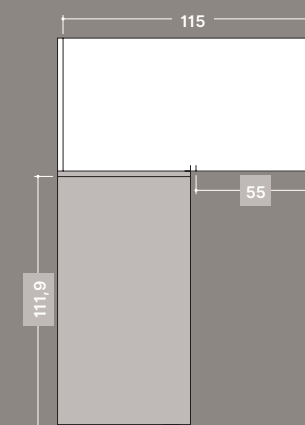

articolo **120**
angolo a 90° in TANGANIKA 1 anta
battente DX o SX. TANGANIKA 90° corner
1 DX or SX hinged door.
cm. h. 256 p. 65

MISURE dalle misure indicate manca sporgenza cappello di 5,5 cm. per lato.
MEASURES from the measures indicated there is no boss protrusion of 5.5 cm. on the side.



articolo 137
 armadio angolo terminale 45° DX/SX in TANGANIKAI 1 anta battente.
 TANGANIKAI terminal corner wardrobe 45° right/left 1 hinged door.
 cm. l. 58,3 p. 27,3/60+cornici h. 256

articolo 124
 armadio in TANGANIKAI 1 anta battente.
 TANGANIKAI wardrobe 1 hinged door.
 cm. l. 60+cornici p. 60 h. 256

articolo 138
 armadio in TANGANIKAI 1 anta battente con cassettera.
 TANGANIKAI wardrobe 1 hinged door with drawers dresser.
 cm. l. 60 p. 60+cornici h. 256

articolo 125
 armadio in TANGANIKAI 2 ante battenti.
 TANGANIKAI wardrobe 2 hinged doors.
 cm. l. 117 p. 60+cornici h. 256

bedroom furniture classic design



elementi singoli per armadi componibili single elements for modular wardrobes



articolo 139
 armadio in TANGANIKAI 2 ante battenti con cassettera.
 TANGANIKAI wardrobe 2 hinged doors with drawers dresser.
 cm. l. 117 p. 60+cornici h. 256

articolo 126
 armadio in TANGANIKAI 3 ante battenti.
 TANGANIKAI wardrobe 3 hinged doors.
 cm. l. 176 p. 60+cornici h. 256

ESEMPIO DI COMPONIBILITÀ semplice, razionale e versatile. UN SISTEMA flessibile di componenti modulari in grado di soddisfare le specifiche esigenze del Vostro progetto. Presentiamo alcune soluzioni, forse le più classiche, ricordando che su ognuna si può intervenire aggiungendo una o più colonne singole di 60 cm. oppure doppie di 117 cm.

COMPONIBILITY EXAMPLE simple, rational and versatile. Flexible SYSTEM of modular components able to meet the specific needs of your project. We present some solutions, perhaps the most classic ones, remembering that one can intervene on each one by adding one or more single columns of 60 cm. or double of 117 cm.

ANTE DISPONIBILI ANCHE SENZA TRAVERSO.
DOORS ALSO AVAILABLE WITHOUT CROSSPIECE.



articolo 127
 armadio in TANGANIKAI 4 ante battenti.
 TANGANIKAI wardrobe 4 hinged doors.
 cm. l. 234+cornici p. 60 h. 256



articolo 128
 armadio in TANGANIKAI 5 ante battenti.
 TANGANIKAI wardrobe 5 hinged doors.
 cm. l. 289 p. 60+cornici h. 256

ANTE DISPONIBILI ANCHE SENZA TRAVERSO.
DOORS ALSO AVAILABLE WITHOUT CROSSPIECE.



articolo 129
 armadio in TANGANIKAI 6 ante battenti.
 TANGANIKAI wardrobe 6 hinged doors.
 cm. l. 346 p. 60+cornici h. 256

OPTINAL per armadi da aggiungere al momento dell'ordine. wardrobe **OPTIONAL** to be added when ordering.



articolo 130
 ripiano corto. little shelf.
 cm. l. 55 p. 55 sp. 3

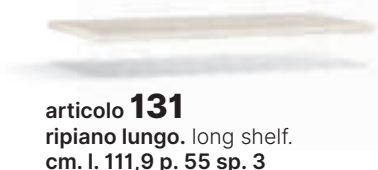

articolo 131
 ripiano lungo. long shelf.
 cm. l. 111,9 p. 55 sp. 3



articolo 132
 cassettera corta 3 cassetti.
 little 3 drawers dresser.
 cm. l. 55 p. 55 h. 65



articolo 133
 cassettera lunga 3 cassetti.
 long 3 drawers dresser.
 cm. l. 111,9 p. 55 h. 65



articolo 134
 traforo centrale.
 central perforated.



articolo 135
 traforo sotto e sopra.
 below and above perforated.



articolo 136
 specchio per anta.
 mirror for door.

LA NOTTE

I gruppi notte completano e danno ordine al tuo ambiente. Elementi imprescindibili per ogni camera da letto. La camera da letto deve assolvere a bisogni e funzioni in continua evoluzione, così, oltre all'armadio e al letto, i gruppi notte assumono un ruolo chiave nell'economia del tuo ambiente. Soluzioni ergonomiche che rendono maggiormente fruibili i nostri ambienti favorendo la sistemazione di indumenti, biancheria e oggetti di uso quotidiano. Oltre alla indiscussa funzionalità, i nostri gruppi notte completeranno la zona notte, sottolineando il fascino e la bellezza dell'ambiente. Gruppi comò e comodini in stile classico, con ribalta, con cassetti, con frontali intarsiati nelle finiture noce bassano o decorati nelle finiture avorio panna, o in stile contemporaneo con linee pulite e finiture chiare e ancora in stile barocco con fianchi sinuosi e intagli e fregi in foglia oro. Tutto il meglio per arricchire sempre con stile la vostra camera da letto.

The sleeping groups complete and give order to your environment. Essential elements for every bedroom. The bedroom must fulfill constantly evolving needs and functions, so, in addition to the wardrobe and the bed, sleeping groups play a key role in the economy of your environment. Ergonomic solutions that make our environments more usable by facilitating the storage of clothing, linen and everyday objects. In addition to the undisputed functionality, our sleeping groups will complete the sleeping area, underlining the charm and beauty of the environment. Groups of dressers and bedside tables in classic style, with flap, with drawers, with fronts inlaid in Bassano walnut finishes or decorated in ivory cream finishes, or in contemporary style with clean lines and light finishes and also in Baroque style with sinuous sides and carvings and friezes in gold leaf. All the best to always enrich your bedroom with style.

dressers groups
classic design



I gruppi

Italiancollectionsdressers 482



comò
comodini
specchiere

dressers groups
classic design



i Gruppi

483 Italiancollectionsdressers



Ferrara

dressers groups
classic design



gruppo **FERRARA**

comò con 4 cassetti.
chest of drawers with 4 drawers.
cm. l. 123 p. 55 h. 116

comodino con 3 cassetti.
bedside table with 3 drawers.
cm. l. 57 p. 40 h. 71



Sono le finezze a creare una trama preziosa, come in un gioiello artigianale che racchiude in sé un mondo di autentica bellezza. Espressione di stile, di unicità, di eleganza e raffinatezza. Progettare un concetto, rendere uno spazio al di fuori delle tendenze comuni, saper stupire con elementi semplici ma al contempo raffinati in ogni sua forma. Comò e comodini in legno intarsiato e laccato a mano, dotati di cassetti, arricchiti da decorazioni dorate, realizzate in stile classico di lusso, ideale per uso alberghiero e residenziale. Il legno intagliato da mani sapienti, le finiture in foglia oro e argento si fondono con l'antica artigianalità per dar vita al gruppo ferrara. Linee e colori abbinati allo stile dei mobili e design attuale, sono le caratteristiche dei nostri prodotti e fiduciosi ci rivolgiamo al pubblico convinti di offrire le soluzioni più giuste per rappresentare al meglio il tempo in cui viviamo.

It is the subtleties that create a precious texture, as in a handcrafted jewel that embodies a world of authentic beauty. Expression of style, uniqueness, elegance and refinement. Designing a concept, making a space outside of common trends, knowing how to amaze with simple but at the same time refined elements in all their forms. Dresser and bedside tables in hand-inlaid and lacquered wood, equipped with drawers, enriched with golden decorations, made in a classic luxury style, ideal for hotel and residential use. The wood carved by expert hands, the gold and silver leaf finishes blend with ancient craftsmanship to give life to the Ferrara group. Lines and colors combined with the style of furniture and current design are the characteristics of our products and we confidently address the public convinced that we are offering the right solutions to best represent the time in which we live.



Bari

dressers groups
classic design



gruppo BARI

comò intarsiato con 4 cassetti.
inlaid chest of 4 drawers.
cm. l. 140 p. 59 h. 127

comodino intarsiato con 3 cassetti.
inlaid bedside table 3 drawers.
cm. l. 66 p. 41 h. 79



dressers groups
classic design

Alghero



gruppo ALGHERO

comò intarsiato con 3 cassetti e ribalta.
inlaid chest of 3 drawers with flap door.
cm. l. 130 p. 56 h. 120

comodino intarsiato con 3 cassetti.
inlaid bedside table 3 drawers.
cm. l. 60 p. 42 h. 73



dressers groups
classic design

Catania



gruppo **CATANIA**

comò intarsiato con 4 cassetti.
inlaid chest of 4 drawers.
cm. l. 133 p. 56 h. 125

comodino intarsiato con 3 cassetti.
inlaid bedside table 3 drawers.
cm. l. 60 p. 40 h. 75



gruppo **CATANIA**

comò con 4 cassetti.
chest of drawers with 4 drawers.
cm. l. 133 p. 56 h. 125

comodino con 3 cassetti.
bedside table with 3 drawers.
cm. l. 60 p. 40 h. 75

Catania →

dressers groups
classic design



gruppo **MILANO**
comò con 5 cassetti.
 chest of drawers with 5 drawers.
 cm. l. 130 p. 55 h. 130

comodino con 3 cassetti.
 bedside table with 3 drawers.
 cm. l. 60 p. 40 h. 73

dressers groups
 classic design

Milano



gruppo **MILANO**
comò intarsiato con 5 cassetti e ribalta.
 inlaid chest of 3 drawers with flap door.
 cm. l. 130 p. 55 h. 130

comodino intarsiato con 3 cassetti.
 inlaid bedside table 3 drawers.
 cm. l. 60 p. 40 h. 73

Milano

dressers groups
 classic design



gruppo **NAPOLI**

comò intarsiato con 4 cassetti e ribalta.
inlaid chest of 4 drawers with flap door.
cm. l. 120 p. 55 h. 128

comodino intarsiato con 3 cassetti.
inlaid bedside table 3 drawers.
cm. l. 51 p. 40 h. 75

Napoli

dressers groups
classic design



articolo **2140**
comò 4 cassetti da laccare
con guide ammortizzate. chest of 4 drawers
to be lacquered with soft closing.
cm. l. 134,5 p. 62 h. 113

articolo **2141**
comodino 3 cassetti da laccare
con guide ammortizzate. bedside table
3 drawers to be lacquered with soft closing.
cm. l. 64 p. 42,5 h. 74,5

articolo **2144**
specchiera ovale da laccare
specchio liscio. oval frame to be
lacquered with smooth mirror.
cm. l. 90 h. 60

dressers groups
classic design

Viola



dressers groups
classic design

Caserta

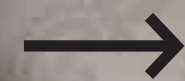

gruppo **CASERTA**

comò con 4 cassetti e ribalta.
chest of 4 drawers with flap door.
cm. l. 127 p. 61 h. 117

comodino con 3 cassetti.
bedside table with 3 drawers.
cm. l. 61 p. 43 h. 73

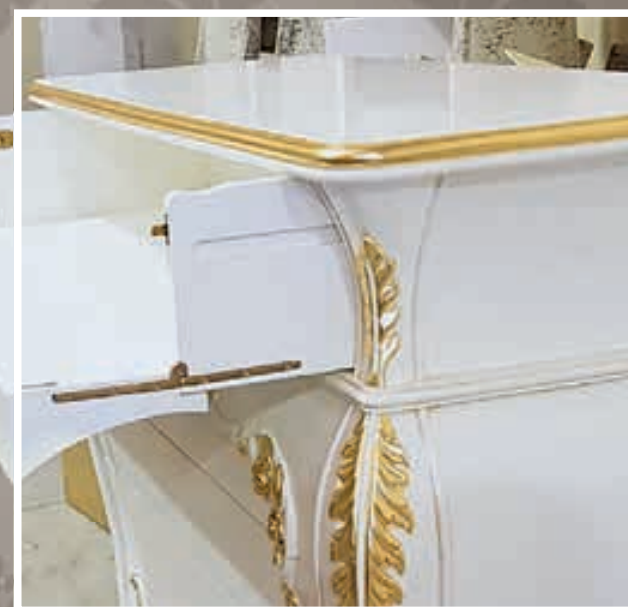

gruppo **VIAREGGIO**

comò con 4 cassetti.
chest of drawers with 4 drawers.
cm. l. 134 p. 64 h. 119

comodino con 3 cassetti.
bedside table with 3 drawers.
cm. l. 64 p. 41 h. 72

← Viareggio

dressers groups
classic design



gruppo **PALERMO**

comò con 4 cassetti e ribalta.
chest of 4 drawers with flap door.
cm. l. 126 p. 58 h. 123

comodino con 3 cassetti.
bedside table with 3 drawers.
cm. l. 60 p. 42 h. 75



dressers groups
classic design

Palermo

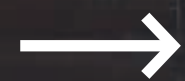

dressers groups
classic design

Palermo

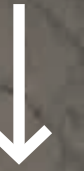

gruppo **PALERMO**

comò intarsiato con 4 cassetti e ribalta.
inlaid chest of 4 drawers with flap door.
cm. l. 126 p. 58 h. 123

comodino intarsiato con 3 cassetti.
inlaid bedside table 3 drawers.
cm. l. 60 p. 42 h. 75



gruppo **URBINO**

comò sagomato con 3 cassetti.
shaped chest of 3 drawers.
cm. l. 118 p. 58 h. 85

comodino sagomato con 2 cassetti.
shaped bedside table with 2 drawers.
cm. l. 50 p. 30 h. 60

dressers groups
classic design

← **Urbino**



gruppo **GEMMA120**

comò sagomato con 3 cassetti.
3 drawers shaped chest of drawer.
cm. l. 120 p. 42 h. 85

comodino sagomato con 2 cassetti.
shaped 2 drawers bedside table.
cm. l. 50 p. 30 h. 60

gruppo **GEMMA105**

comò sagomato con 3 cassetti.
3 drawers shaped chest of drawer.
cm. l. 105 p. 42 h. 85

comodino sagomato con 2 cassetti.
shaped 2 drawers bedside table.
cm. l. 50 p. 30 h. 60

specchiera rotonda traforata.
perforated round mirror.
cm. ø. 94



dressers groups
classic design

← **Gemma**

gruppo GIADA105

comò sagomato con 3 cassetti.
3 drawers shaped chest of drawer.
cm. l. 105 p. 42 h. 85

comodino sagomato con 2 cassetti.
shaped 2 drawers bedside table.
cm. l. 50 p. 30 h. 60

specchiera rettangolare traforata.
perforated rectangular mirror.
cm. l. 102 sp. 11 h. 76



gruppo GIADA120

comò sagomato con 3 cassetti.
3 drawers shaped chest of drawer.
cm. l. 120 p. 42 h. 85

comodino sagomato con 2 cassetti.
shaped 2 drawers bedside table.
cm. l. 50 p. 30 h. 60

dressers groups
classic design

Giada



gruppo AMBRA105

comò sagomato con 3 cassetti.
3 drawers shaped chest of drawer.
cm. l. 105 p. 42 h. 85

comodino sagomato con 2 cassetti.
shaped 2 drawers bedside table.
cm. l. 50 p. 30 h. 60

gruppo AMBRA120

comò sagomato con 3 cassetti
3 drawers shaped chest of drawer
cm. l. 120 p. 42 h. 85

comodino sagomato con 2 cassetti
shaped 2 drawers bedside table
cm. l. 50 p. 30 h. 60

pecchiera rettangolare traforata.
perforated rectangular mirror.
cm. l. 102 sp. 11 h. 76



← Ambra

dressers groups
classic design

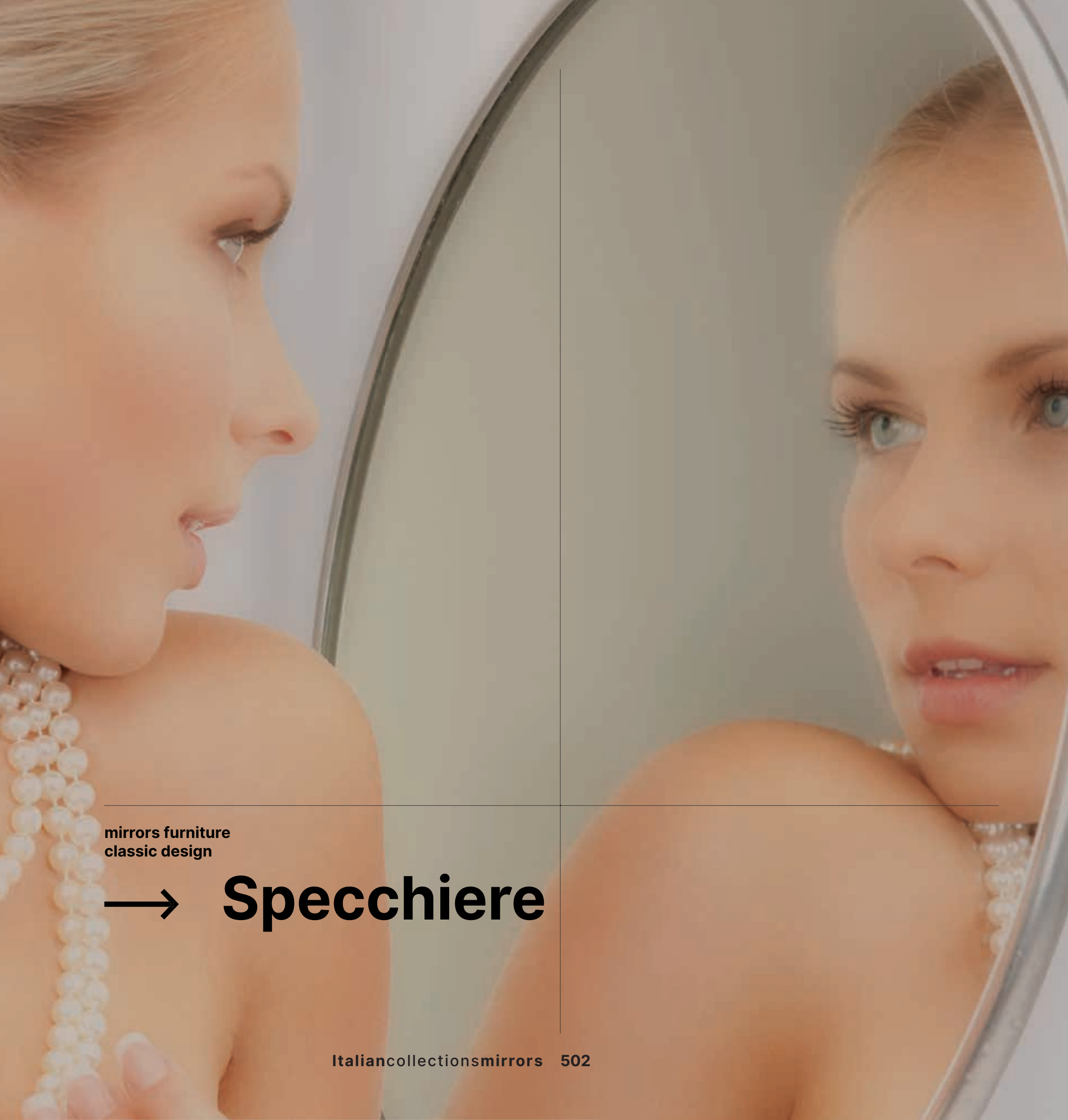

**mirrors furniture
classic design**

→ **Specchiere**

L'artigianalità del Made in Italy è inconfondibile ecco per voi la selezione delle specchiere con forme e trafori caratteristici del design italiano, cura del dettaglio e originalità garantita. Le cornici sono glamour e affascinanti per donare l'inconfondibile connotazione fashion dello stile italiano al proprio ambiente all'insegna di qualità e affidabilità. Superfici riflettenti per decorare senza rinunciare all'utilità, specchi dalle cornici lavorate o minimaliste, questa sezione vi offre soluzioni uniche per le vostre esigenze. Lo specchio nasce come elemento funzionale per guardarsi e trova naturale collocazione in ambienti quali la camera da letto, il bagno o l'ingresso di casa o per diffondere la luce negli ambienti, o ancora aumentare la prospettiva degli spazi. Da parete per riflettere il viso o a figura intera, ogni elemento può soddisfare i vostri desideri e aggiungere funzioni utili a complementi d'arredo originali. Anche se di solito siamo convinti di sapere dove appenderli e non ci facciamo molto caso, gli specchi sono tra i migliori amici degli arredatori per diversi motivi. Uno specchio ben piazzato sfrutta al meglio la luce naturale in una stanza, aumenta la percezione degli spazi e aggiunge un look più brillante a tutto l'arredamento. Il segreto sta nell'abbinare lo specchio al resto del mobilio e a indovinare la posizione giusta per farlo rendere al meglio. Ecco qualche consiglio, valido non solo per le stanze piccole che ne trarranno comunque un enorme beneficio, ma anche a tutti i locali della casa, di qualsiasi dimensione e struttura.

The craftsmanship of Made in Italy is unmistakable here for you the selection of mirrors with shapes and openwork characteristic of Italian design, attention to detail and guaranteed originality. The frames are glamorous and fascinating to give the unmistakable fashion connotation of Italian style to your environment in the name of quality and reliability. Reflective surfaces to decorate without sacrificing utility, mirrors with machined or minimalist frames, this section offers you unique solutions for your needs. The mirror was born as a functional element for looking at itself and finds its natural location in environments such as the bedroom, bathroom or entrance to the house or to diffuse light in the rooms, or even to increase the perspective of the spaces. Wall-mounted to reflect the face or full-length, each element can satisfy your desires and add useful functions to original furnishing accessories. Although we are usually convinced that we know where to hang them and we don't pay much attention to them, mirrors are among the best friends of interior designers for several reasons. A well-placed mirror makes the best use of natural light in a room, increases the perception of spaces and adds a brighter look to all the furnishings. The secret lies in combining the mirror with the rest of the furniture and guessing the right position to make it look its best. Here are some tips, valid not only for small rooms that will still benefit enormously, but also for all rooms in the house, of any size and structure.

**mirrors furniture
classic design**

→ **Specchiere**



Italiancollectionsmirrors 504



505 Italiancollectionsmirrors

Entrata

mirrors furniture
classic design



articolo **3290**
specchiera con cornice traforata
e contenitore interno. mirror with perforated
frame and internal container.
cm. l. 102 p. 40 h. 162

disponibile su misura.
available by custom.



gruppo **402**
specchiera rettangolare traforata.
perforated rectangular mirror.
cm. l. 110 sp. 1,3 h. 80

tutte le specchiere possono essere
personalizzate con nomi che si desiderano.
all the mirrors can be customized with names you want.

gruppo **410**
specchiera rettangolare traforata.
perforated rectangular mirror.
cm. l. 80 sp. 1,3 h. 109

mirrors furniture
classic design

← Specchiere

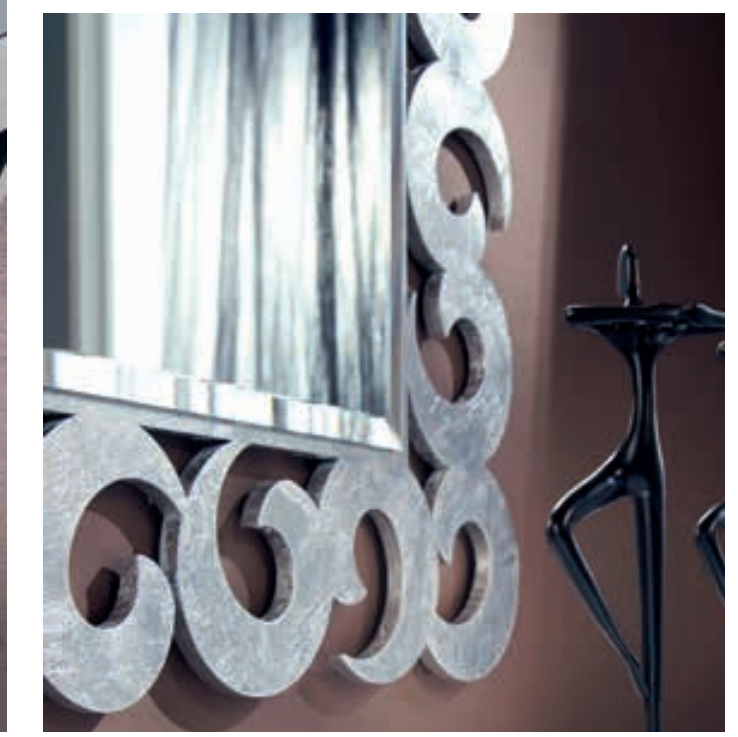



gruppo **404**
specchiera quadrata traforata.
perforated square mirror.
cm. l. 90 sp. 1,3 h. 90



Italiancollectionsmirrors 508

gruppo **414**
specchiera quadrata traforata.
perforated square mirror.
cm. l. 90 sp. 1,3 h. 90



gruppo **408**
specchiera rettangolare traforata.
perforated rectangular mirror.
cm. l. 86 sp. 1,3 h. 115

Specchiere

mirrors furniture
classic design



gruppo **412**
specchiera rettangolare traforata.
perforated rectangular mirror.
cm. l. 60 sp. 1,3 h. 115



509 Italiancollectionsmirrors



gruppo 415
specchiera rettangolare traforata.
perforated rectangular mirror.
cm. l. 160 sp. 1,3 h. 79

**mirrors furniture
classic design**

← Specchiere

gruppo 405
specchiera rettangolare traforata.
perforated rectangular mirror.
cm. l. 80 sp. 1,3 h. 175



gruppo 401
specchiera rettangolare traforata.
perforated rectangular mirror.
cm. l. 65 sp. 1,3 h. 103



gruppo 413
specchiera rettangolare traforata.
perforated rectangular mirror.
cm. l. 102 sp. 1,3 h. 70



gruppo **426**
specchiera rotonda traforata.
perforated round mirror.
cm. ø. 85 sp. 1,3



gruppo **431**
specchiera rotonda traforata.
perforated round mirror.
cm. ø. 100 sp. 1,3



gruppo **406**
specchiera rotonda traforata.
perforated round mirror.
cm. ø. 85 sp. 1,3



gruppo **419**
specchiera rettangolare traforata.
perforated rectangular mirror.
cm. l. 60 sp. 1,3 h. 93



Specchiere →

mirrors furniture
classic design

gruppo **429**
specchiera rettangolare traforata.
perforated rectangular mirror.
cm. l. 108 sp. 1,3 h. 81



gruppo **430**
specchiera rettangolare traforata.
perforated rectangular mirror.
cm. l. 78 sp. 1,3 h. 105



gruppo **411**
specchiera rettangolare traforata.
perforated rectangular mirror.
cm. l. 109 sp. 1,3 h. 82



mirrors furniture
classic design

← Specchiere

gruppo **434**
specchiera rettangolare traforata.
perforated rectangular mirror.
cm. l. 170 sp. 1,3 h. 90





gruppo **428**
specchiera rettangolare traforata.
perforated rectangular mirror.
cm. l. 106,5 sp. 1,3 h. 78,2



gruppo **432**
specchiera rotonda traforata.
perforated round mirror.
cm. ø. 100 sp. 1,3



Italiancollectionsmirrors 516

gruppo **421**
specchiera rettangolare traforata.
perforated rectangular mirror.
cm. l. 76 sp. 1,3 h. 94



← **Specchiere**
mirrors furniture
classic design

gruppo **425**
specchiera rettangolare traforata.
perforated rectangular mirror.
cm. l. 71 sp. 1,3 h. 98

517 Italiancollectionsmirrors



gruppo **433**
specchiera rettangolare traforata.
perforated rectangular mirror.
cm. l. 83 sp. 1,3 h. 108

gruppo **427**
specchiera rotonda traforata.
perforated round mirror.
cm. ø. 82 sp. 1,3



gruppo **424**
specchiera quadrata traforata.
perforated square mirror.
cm. l. 90 sp. 1,3 h. 90



mirrors furniture
classic design

← Specchiere

gruppo **420**
specchiera rettangolare traforata.
perforated rectangular mirror.
cm. l. 88 sp. 1,3 h. 110





gruppo 422
specchiera rettangolare traforata.
perforated rectangular mirror.
cm. l. 76,4 sp. 1,3 h. 99,7



Italiancollectionsmirrors 520



gruppo 416
specchiera rotonda traforata.
perforated round mirror.
cm. ø. 80 sp. 1,3



gruppo 435
specchiera rettangolare traforata.
perforated rectangular mirror.
cm. l. 90 sp. 1,3 h. 170

← **Specchiere**
mirrors furniture
classic design

521 Italiancollectionsmirrors

gruppo 409
specchiera rettangolare traforata.
perforated rectangular mirror.
cm. l. 85,5 sp. 1,3 h. 113



mirrors furniture
classic design

Specchiere →



gruppo 403
specchiera quadrata traforata.
perforated square mirror.
cm. l. 92 sp. 1,3 h. 92



gruppo 417
specchiera rettangolare traforata.
perforated rectangular mirror.
cm. l. 67 sp. 1,3 h. 100



Questo catalogo è di proprietà della ditta e viene dato in uso esclusivamente ai rivenditori autorizzati. Qualsiasi uso da parte di persone non autorizzate è perseguibile secondo i termini previsti dalla legge. È vietata la riproduzione e l'alterazione, anche in forma digitale, delle fotografie e dei marchi riprodotti nel catalogo.

**Le eventuali differenze nei colori stampati non possono essere considerate difetti.
Le misure riportate sul catalogo sono da valutarsi come indicative.**

The copyright of this catalogue belongs exclusively to company. It is for the exclusive use of registered customers only. All contents are copyrighted. the contents may not be reproduced in whole or in part without written consent of copyright owner.

**We cannot accept any complaint on difference from the colours printed in this catalogue.
The measures listed in the catalogue are assessed as indicative.**

 **MADE IN ITALY**

**furniture contemporary
and classic made in Italy**



Anthologia 2.4